

# MODEL APF/APFW-200-400 INSTALLATION INSTRUCTIONS

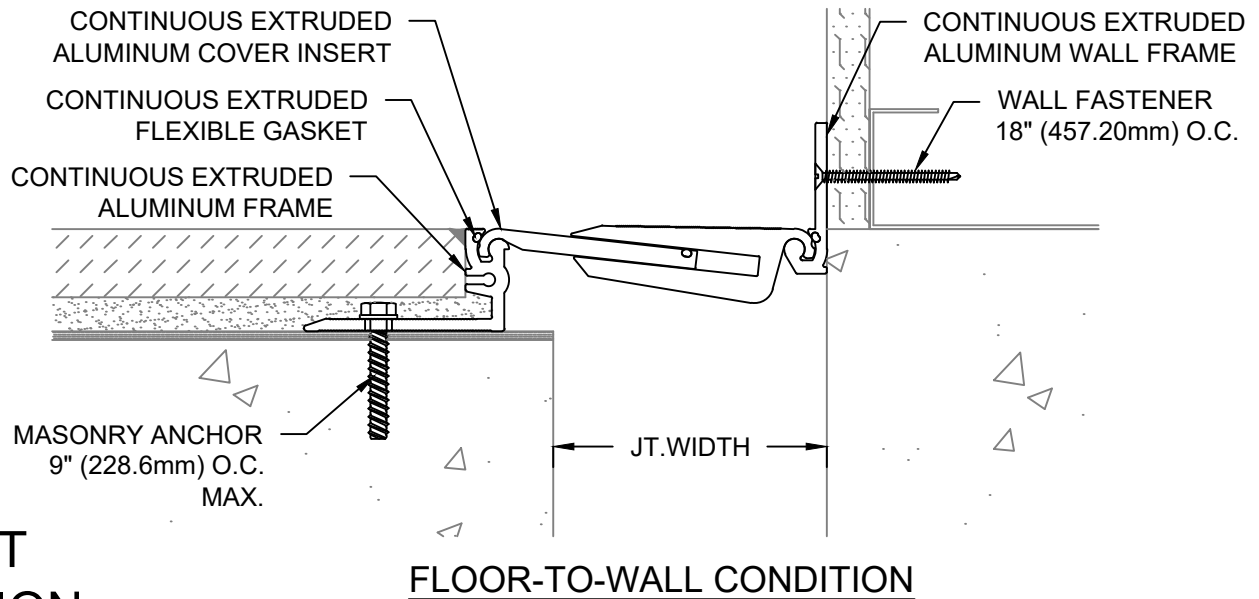
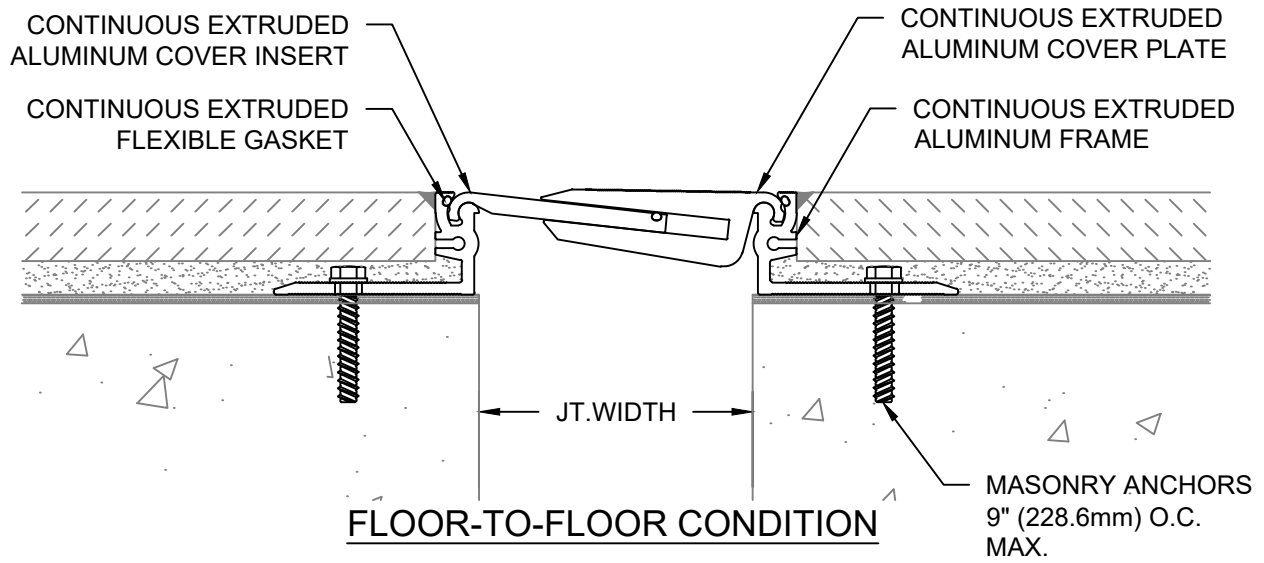

## IMPORTANT INFORMATION

Prior to the commencement of installation, all materials **MUST** be inspected for damage. Any damage must be reported to CONSTRUCTION SPECIALTIES, INC., as soon as possible, so that replacement materials may be furnished without delay.

All work must be completed as per Architect's Approved "Shop Drawings", and in accordance with these Installation Instructions. When installation is complete, all materials must be protected from damage until the Architect's FINAL INSPECTION.

All materials should be arranged in the order that they are to be installed. All hardware required for each portion of the work should be placed with the appropriate materials.

Please review all Approved Shop Drawings and this document to familiarize yourself with all the details and components of this assembly.

**IMPORTANT:**  
READ THROUGH ALL INSTRUCTIONS PRIOR TO STARTING INSTALLATION

8/08/19



**Construction Specialties™**

6696 Route 405 Highway, Muncy PA 17756  
(800) 233-8493 • Fax (570) 546-5169 • www.CSgroup.com

This document is the property of Construction Specialties, Inc. and contains CONFIDENTIAL PROPRIETARY INFORMATION that is not to be disclosed to third parties and is not to be used without approval in writing from Construction Specialties, Inc.

**Notes**

Before beginning installation, review the architectural drawings and approved Construction Specialties Inc. shop drawings to familiarize yourself with the joint cover models and locations.

Check all of the joint cover components to confirm that the correct joint cover model and size have been received. Also, check for materials that may have been damaged during shipping. Report all incorrect and/or damaged components to CS at 800-233-8493.

Read through all the steps of these instructions prior to beginning work.

**CONTENTS:**

I. Floor-to-Floor Joints only ..... Page 2  
 II. Floor-to-Wall Joints only ..... Page 4  
 III. Joints that transition from Floor-to-Floor to Floor-to-Wall ..... Page 6

**STEP 1 - FLOOR TO FLOOR JOINTS ONLY**

\*Note: The rest of the Assembly is not shown for clarity. System comes fully assembled.

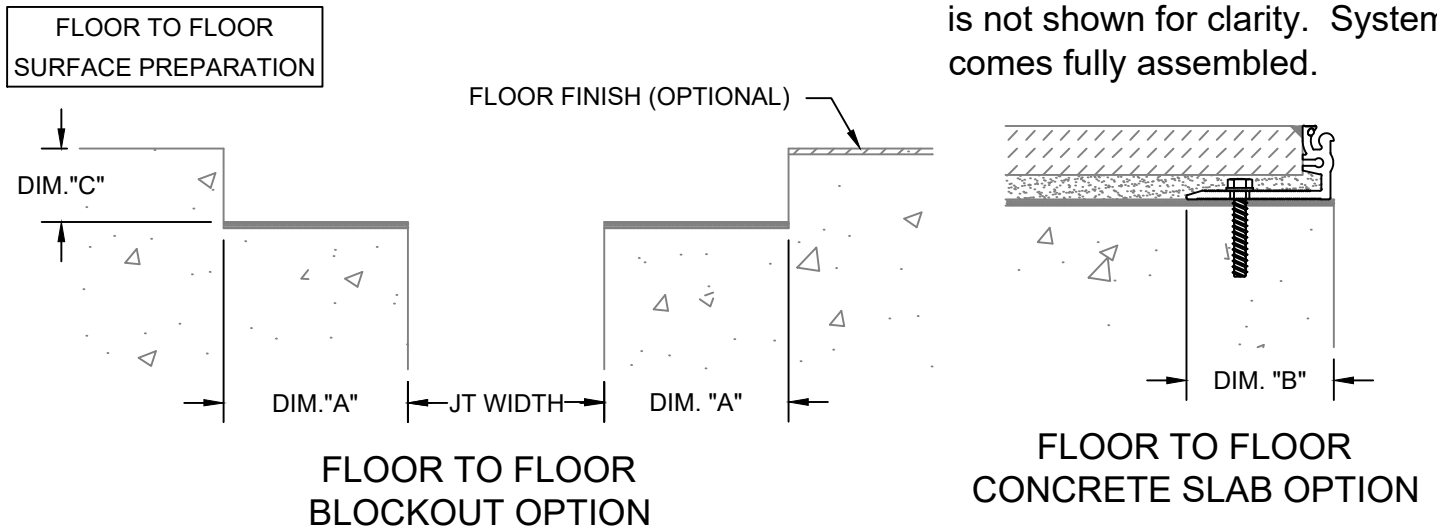

Model	Jt. Width	DIM."A"	DIM."B"	DIM."C"
APF-200 x1 1/2"	2"(50.8mm)	3 3/4"(95.25mm)	3"(76.20mm)	1 1/2"(38mm)
APF-200 x 2"	2"(50.8mm)	3 3/4"(95.25mm)	3"(76.20mm)	2"(50mm)
APF-300 x 1 1/2"	3"(76.2mm)	3 3/4"(95.25mm)	3"(76.20mm)	1 1/2"(38mm)
APF-300 x 2"	3"(76.2mm)	3 3/4"(95.25mm)	3"(76.20mm)	2"(50mm)
APF-400 x 1 1/2"	4"(101.6mm)	3 3/4"(95.25mm)	3"(76.20mm)	1 1/2"(38mm)
APF-400 x 2"	4"(101.6mm)	3 3/4"(95.25mm)	3"(76.20mm)	2"(50mm)

**STEP 1:**

- 1.1) The blockouts must be prepared to receive the joint cover.
- 1.2) Refer to table above for minimum blockout width and the blockout depth. The blockout depth may be adjusted as needed to accommodate a floor finish material when required and as indicated on the architectural drawings and/or CS shop drawings.
- 1.3) It is recommended that the blockouts be formed a minimum of 1/8" deeper to allow the blockouts to be leveled for installation of the joint cover.
- 1.4) Apply a self leveling grout to the base of the blockouts to provide a continuous, solid, flat and level base for the joint cover. (Note: The blockouts must be level across the width of the joint.)
- 1.5) Mark Frame location, DIM."B", in blockout.
- 1.6) As an alternative surface preparation/Floor Frame Installation Method, an epoxy mortar bed can be spread on the surfaces that are going to be receiving the Assemblies. The epoxy mortar bed should be approximately 3/8" [9.53mm] x 5" [127.00mm] wide on both sides of the joint. The epoxy-mortar can be used to fill in any irregularities on the concrete slab or blockout.
- 1.7) The Assembly should be set in the epoxy mortar bed according to DIM. "B" and tapped down until the top surface is the correct elevation, DIM. "C", before it cures. See next page for Assembly Installation.

# STEP 2 - FLOOR TO FLOOR JOINTS ONLY

FLOOR TO FLOOR  
ASSEMBLY INSTALLATION

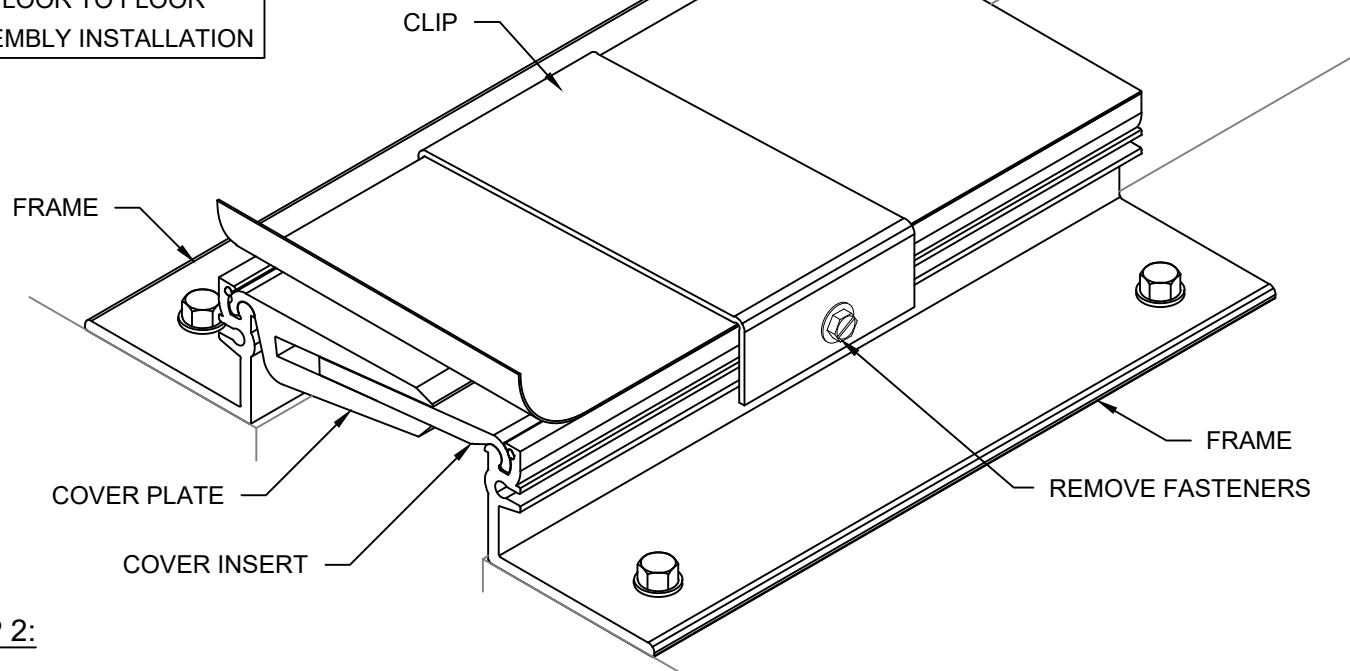

## STEP 2:

### Note:

If a CS Fire Barrier is to be installed in the joint, please review the Fire Barrier Installation Instructions supplied, and if required install the Fire Barrier **BEFORE** installation of CS Seismic Expansion Joint Assemblies. If a Vapor Barrier/Waterstop is to be installed in the joint, please review the Vapor Barrier/Waterstop Installation Instructions supplied, and if required install the Vapor Barrier/Waterstop **BEFORE** installation of CS Seismic Expansion Joint Assemblies.

- 2.1) Begin installation of the Floor to Floor Expansion Joint Cover by centering a length of the Assembly over the joint. Cut to the appropriate length if needed.
- 2.2) Reposition the Assembly over the joint and align the edge of the Frames with Frame location mark from Step 1 on Page 2.
- 2.3) Using holes in the Frame as a template, mark the locations for the CS supplied anchors approximately 6" in from the end (max.) and 9" o.c. max., thereafter.
- 2.4) Remove Assembly and drill holes for CS supplied anchors in accordance to manufacturer's guidelines.
- 2.5) Place Assembly back over joint and attach using the CS supplied anchors per manufacturer's guidelines.
- 2.6) Remove Clips from Expansion Joint Cover Assembly.

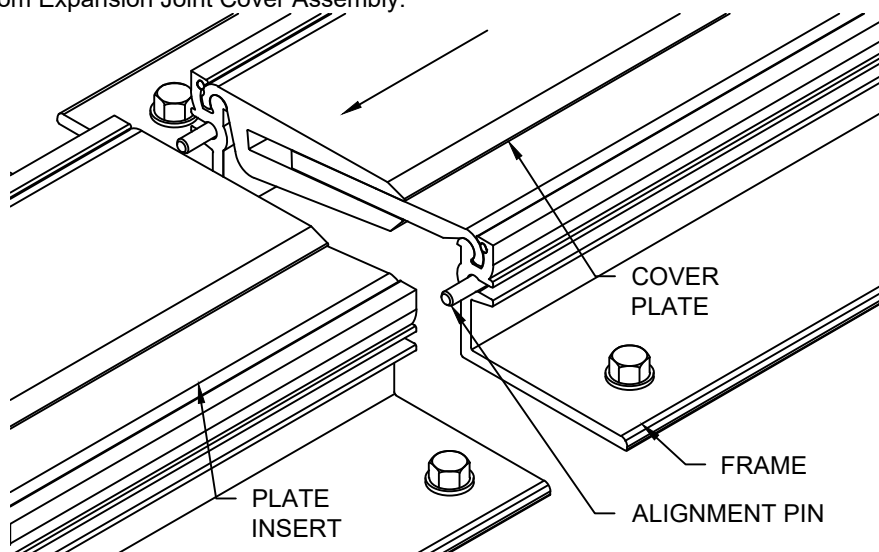

**Note:** To assist in maintaining the alignment of the exposed top edge of Frames for runs longer than 10'-0", Alignment Pins are to be placed in the Frame sections prior to installation.

- 2.7) Insert Alignment Pins into alignment slots of the next length of Frame. Insert the Pin approximately 1/2 of its length.
- 2.8) Align Pins with previous installed section of Assembly alignment slots (see detail above). Repeat Step 2 to install any additional Assemblies.

# STEP 1 - FLOOR TO WALL JOINTS ONLY

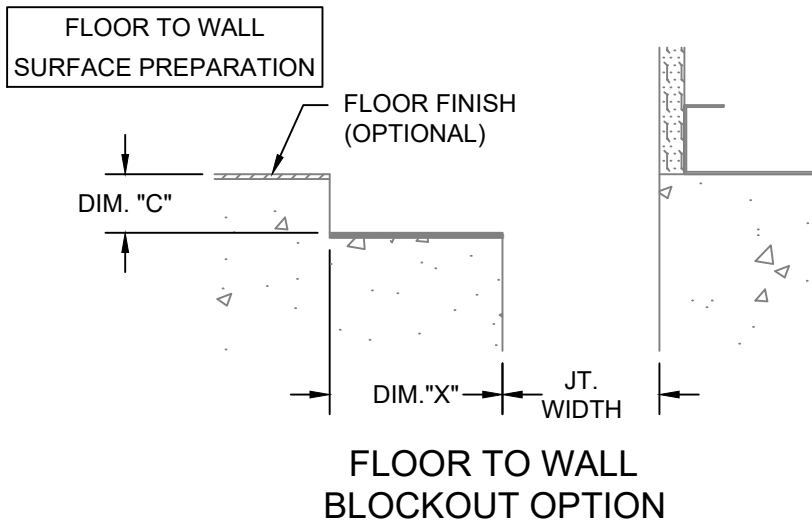

\*Note: The rest of the Assembly is not shown for clarity. System comes fully assembled.

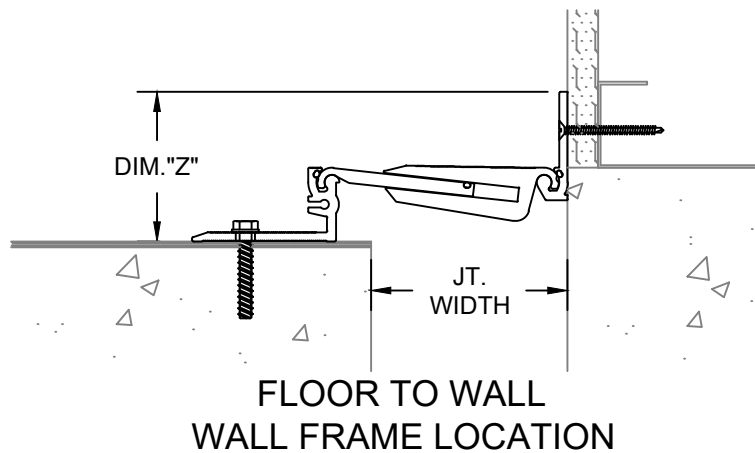
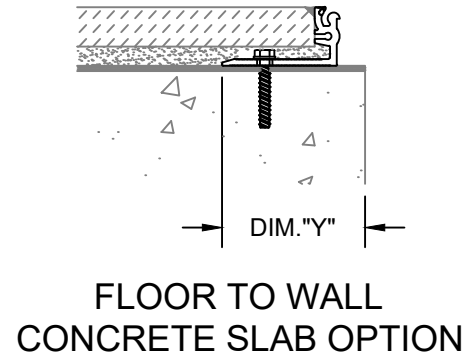

Model	Jt. Width	DIM. "C"	DIM. "X"	DIM. "Y"	DIM. "Z"
APFW-200 x 1 1/2"	2"(50.8mm)	1 1/2"(38mm)	4 1/2"(114.3mm)	3 11/16"(93.66mm)	3"(76.20mm)
APFW-200 x 2"	2"(50.8mm)	2"(50mm)	4 1/2"(114.3mm)	3 11/16"(93.66mm)	3 1/2"(89.90mm)
APFW-300 x 1 1/2"	3"(76.2mm)	1 1/2"(38mm)	4 1/2"(114.3mm)	3 3/4"(95.25mm)	3"(76.20mm)
APFW-300 x 2"	3"(76.2mm)	2"(50mm)	4 1/2"(114.3mm)	3 3/4"(95.25mm)	3 1/2"(89.90mm)
APFW-400 x 1 1/2"	4"(101.6mm)	1 1/2"(38mm)	4 1/2"(114.3mm)	3 11/16"(93.66mm)	3"(76.20mm)
APFW-400 x 2"	4"(101.6mm)	2"(50mm)	4 1/2"(114.3mm)	3 11/16"(93.66mm)	3 1/2"(89.90mm)

## STEP 1:

- 1.1) The blockout must be prepared to receive the joint cover.
- 1.2) Refer to table above for minimum blockout width and the blockout depth. The blockout depth may be adjusted as needed to accommodate a floor finish material when required and as indicated on the architectural drawings and/or CS shop drawings.
- 1.3) It is recommended that the blockouts be formed a minimum of 1/8" deeper to allow the blockouts to be leveled for installation of the joint cover.
- 1.4) Apply a high-strength self-leveling grout to the base of the blockouts to provide a continuous, solid, flat and level base for the joint cover. (Note: The blockouts must be level across the width of the joint.)
- 1.5) Mark Frame and Wall Frame locations, DIM. "Y" and DIM. "Z", in blockout.
- 1.6) As an alternative surface preparation/Floor Frame Installation Method, an epoxy mortar bed can be spread on the surfaces that are going to be receiving the Floor Frame Assemblies. The epoxy mortar bed should be approximately 3/8" [9.53mm] x 5" [127.00mm] wide on slab adjacent to the joint. The epoxy-mortar can be used to fill in any irregularities on the concrete slab.
- 1.7) The Assembly should be set in the epoxy mortar bed according to DIM. "Y" and tapped down until the top surface is the correct elevation, DIM. "C", before it cures. See next page for Assembly Installation.

# STEP 2 - FLOOR TO WALL JOINTS ONLY

FLOOR TO WALL  
ASSEMBLY INSTALLATION

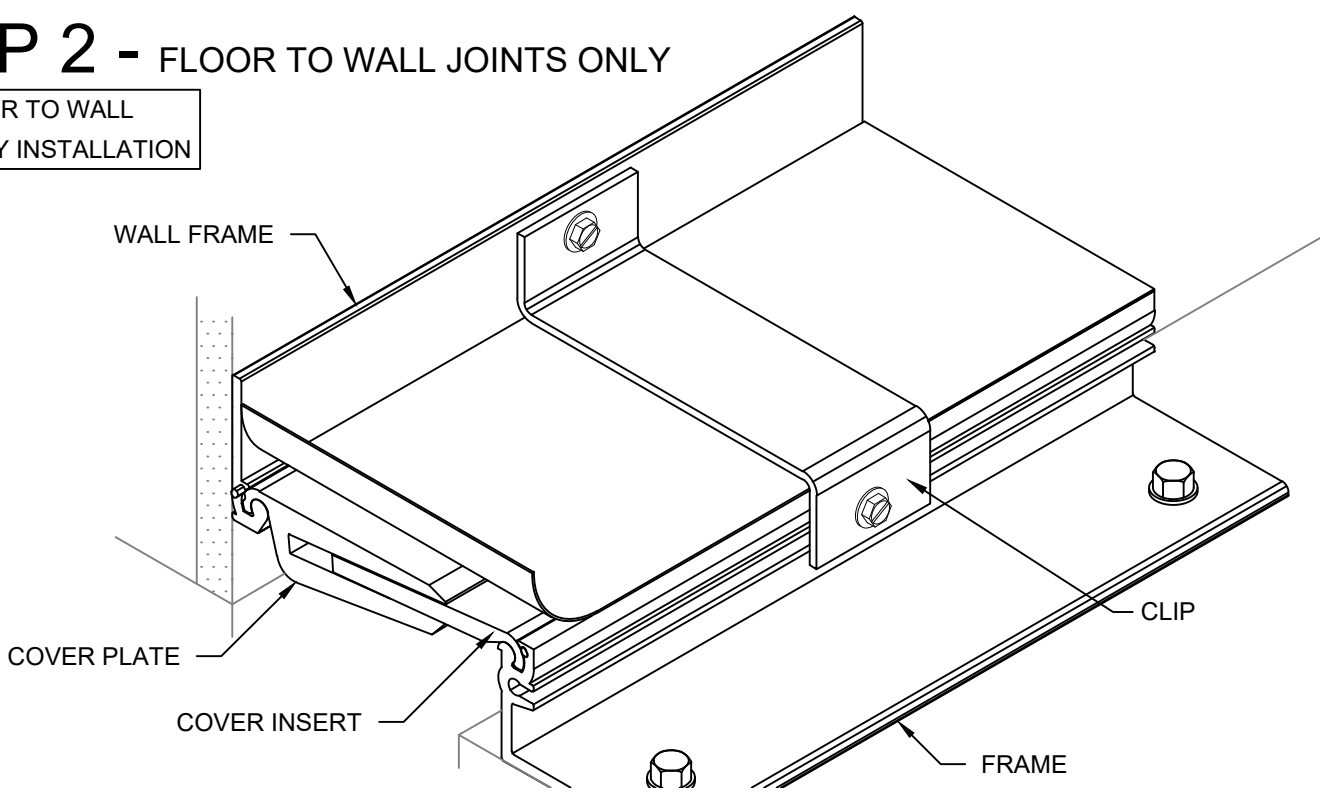

## STEP 3:

### Note:

If a CS Fire Barrier is to be installed in the joint, please review the Fire Barrier Installation Instructions supplied, and if required install the Fire Barrier **BEFORE** installation of CS Seismic Expansion Joint Assemblies. If a Vapor Barrier/Waterstop is to be installed in the joint, please review the Vapor Barrier/Waterstop Installation Instructions supplied, and if required install the Vapor Barrier/Waterstop **BEFORE** installation of CS Seismic Expansion Joint Assemblies.

- 2.1) Begin installation of the Floor to Wall Expansion Joint Cover by centering a length of the Assembly over the joint. Cut to the appropriate length if needed. Note: Do not take the Assembly apart.
- 2.2) Reposition the Assembly over the joint, align edge of Frame and Wall Frame with Frame location marks from Step 1 on Page 4.
- 2.3) Using the holes in the Wall and floor frames as a template, mark the locations for the CS supplied anchors.
- 2.4) Remove Assembly and drill holes for CS supplied anchors in accordance to manufacturer's guidelines.
- 2.5) Place Assembly back over joint and attach using the CS supplied anchors per manufacturer's guidelines.
- 2.6) Remove the clips from expansion joint assembly. Drill, countersink and install 3 CS supplied wall fasteners at wall clip locations.

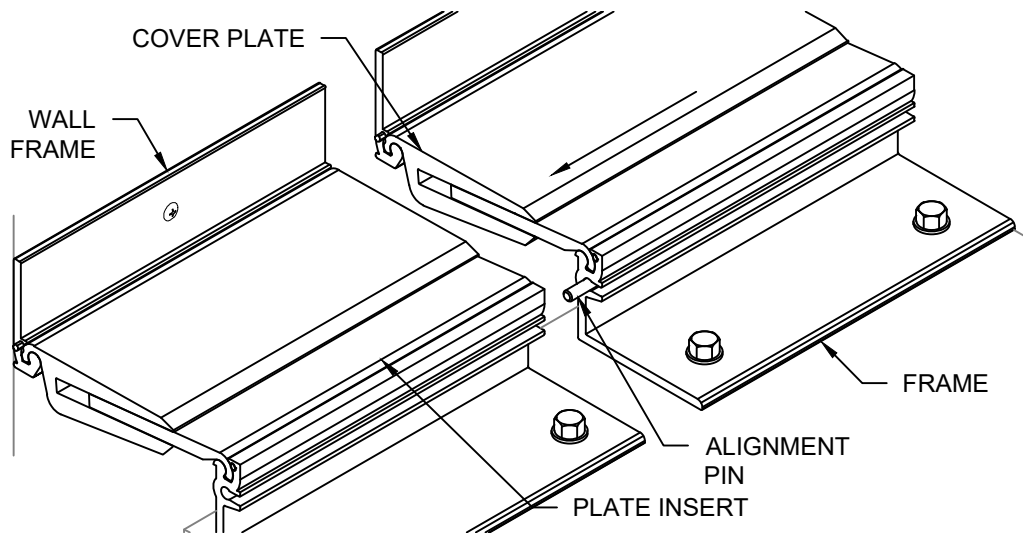

**Note:** To assist in maintaining the alignment of the exposed top edge of Frames for runs longer than 10'-0", Alignment Pins are to be placed in the Frame sections prior to installation.

- 2.7) Insert Alignment Pins into alignment slots of the next length of Frame. Insert the Pin approximately 1/2 of its length.
- 2.8) Align Pins with previous installed Assembly alignment slots (see detail above). Repeat Step 2 to install any additional Assemblies.

# STEP 1 - JOINTS THAT TRANSITION FROM FLOOR-TO-FLOOR TO FLOOR-TO-WALL

FLOOR TO FLOOR THAT WILL TRANSITION TO FLOOR TO WALL SURFACE PREPARATION

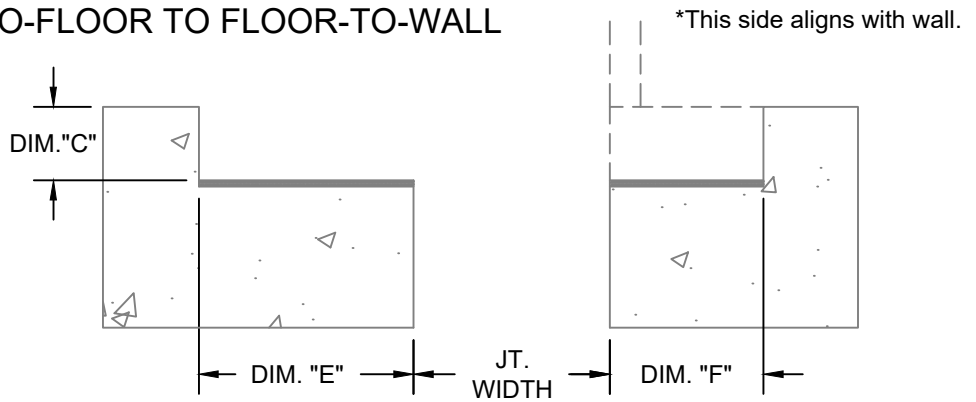

## FLOOR TO FLOOR OFFSETTED BLOCKOUT OPTION

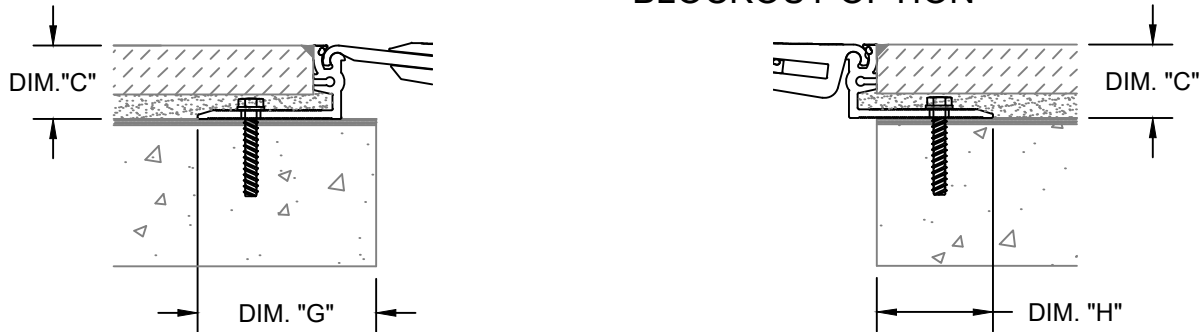

## FLOOR TO FLOOR OFFSETTED FRAME OPPOSITE TO WALL CONCRETE SLAB OPTION

## FLOOR TO FLOOR OFFSETTED FRAME SAME SIDE AS WALL CONCRETE SLAB OPTION

Model	Jt. Width	DIM. "C"	DIM. "E"	DIM. "F"	DIM. "G"	DIM. "H"
APF-200 x 1 1/2"	2"(50.8mm)	1 1/2"(38mm)	4 1/2"(114.3mm)	3 1/8"(79.38mm)	3 11/16"(93.66mm)	2 3/8"(60.33mm)
APF-200 x 2"	2"(50.8mm)	2"(50mm)	4 1/2"(114.3mm)	3 1/8"(79.38mm)	3 11/16"(93.66mm)	2 3/8"(60.33mm)
APF-300 x 1 1/2"	3"(76.2mm)	1 1/2"(38mm)	4 1/2"(114.3mm)	3 1/8"(79.38mm)	3 3/4"(95.25mm)	2 3/8"(60.33mm)
APF-300 x 2"	3"(76.2mm)	2"(50mm)	4 1/2"(114.3mm)	3 1/8"(79.38mm)	3 3/4"(95.25mm)	2 3/8"(60.33mm)
APF-400 x 1 1/2"	4"(101.6mm)	1 1/2"(38mm)	4 1/2"(114.3mm)	3 1/8"(79.38mm)	3 11/16"(93.66mm)	2 3/8"(60.33mm)
APF-400 x 2"	4"(101.6mm)	2"(50mm)	4 1/2"(114.3mm)	3 1/8"(79.38mm)	3 11/16"(93.66mm)	2 3/8"(60.33mm)

### STEP 1:

- 1.1) The blockouts must be prepared to receive the joint cover.
- 1.2) Refer to table above for minimum blockout width and the blockout depth. Note: Floor to floor blockout on the opposite side as Wall Frame is wider (see details above). The blockout depth may be adjusted as needed to accommodate a floor finish material when required and as indicated on the architectural drawings and/or CS shop drawings.
- 1.3) It is recommended that the blockouts be formed a minimum of 1/8" deeper to allow the blockouts to be leveled for installation of the joint cover.
- 1.4) Apply a high-strength self-leveling grout to the base of the blockouts to provide a continuous, solid, flat and level base for the joint cover. (Note: The blockouts must be level across the width of the joint.)
- 1.5) Mark Frame locations, DIM. "G" and "H", in blockout. Note: DIM. "G" will align with the Frame from the Floor to Wall assembly that is opposite of the Wall.
- 1.6) As an alternative surface preparation/Floor Frame Installation Method, an epoxy mortar bed can be spread on the surfaces that are going to be receiving the Floor Frame Assemblies. The epoxy mortar bed should be approximately 3/8" [9.53mm] x 5" [127.00mm] wide on both sides of the joint. The epoxy-mortar can be used to fill in any irregularities on the concrete slab.
- 1.7) The Assembly should be set in the epoxy mortar bed according to DIM. "G" and "H" and tapped down until the top surface is the correct elevation, DIM. "C", before it cures. See next page for Assembly Installation.

# STEP 2 - JOINTS THAT TRANSITION FROM FLOOR-TO-FLOOR TO FLOOR-TO-WALL

FLOOR TO FLOOR OFFSET TO TRANSITION TO FLOOR TO WALL ASSEMBLY INSTALLATION

## STEP 2:

### Note:

If a CS Fire Barrier is to be installed in the joint, please review the Fire Barrier Installation Instructions supplied, and if required install the Fire Barrier **BEFORE** installation of CS Seismic Expansion Joint Assemblies. If a Vapor Barrier/Waterstop is to be installed in the joint, please review the Vapor Barrier/Waterstop Installation Instructions supplied, and if required install the Vapor Barrier/Waterstop **BEFORE** installation of CS Seismic Expansion Joint Assemblies.

**Note:** To assist in maintaining the alignment of the Floor to Floor to the Floor to Wall assemblies, alignment pins are to be placed in the Frame sections prior to installation.

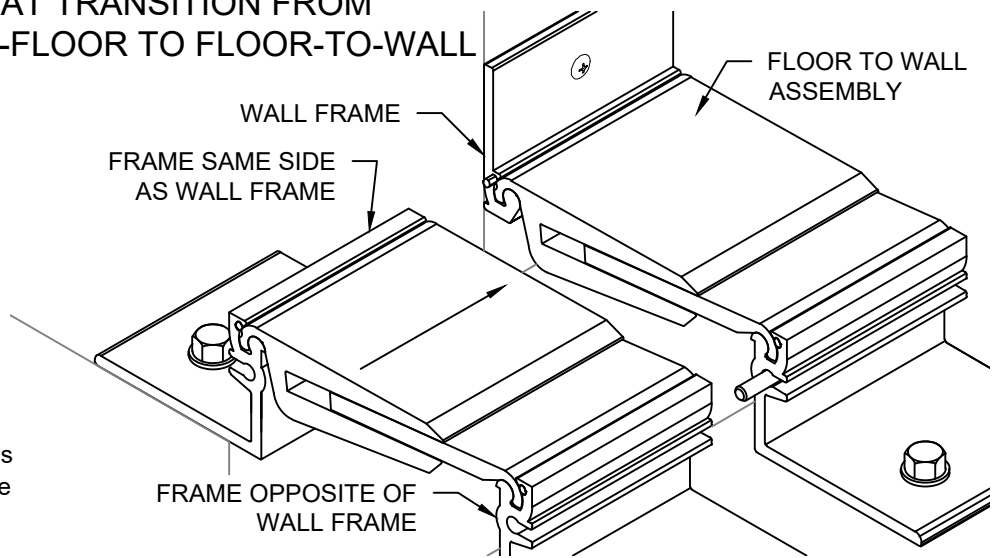

- 2.1) Refer to Page 4 & 5 to install all necessary Floor to Wall Assemblies.
- 2.2) Insert Alignment Pins into alignment slots in the previously installed Floor to Wall Assembly. Insert the pin approximately 1/2 of its length.
- 2.3) Align pin holes of next section of Floor to Floor Assembly with previous installed Floor to Wall Assembly alignment slots (see detail above). Repeat Step 2.1 & 2.2 to install any additional Assemblies.

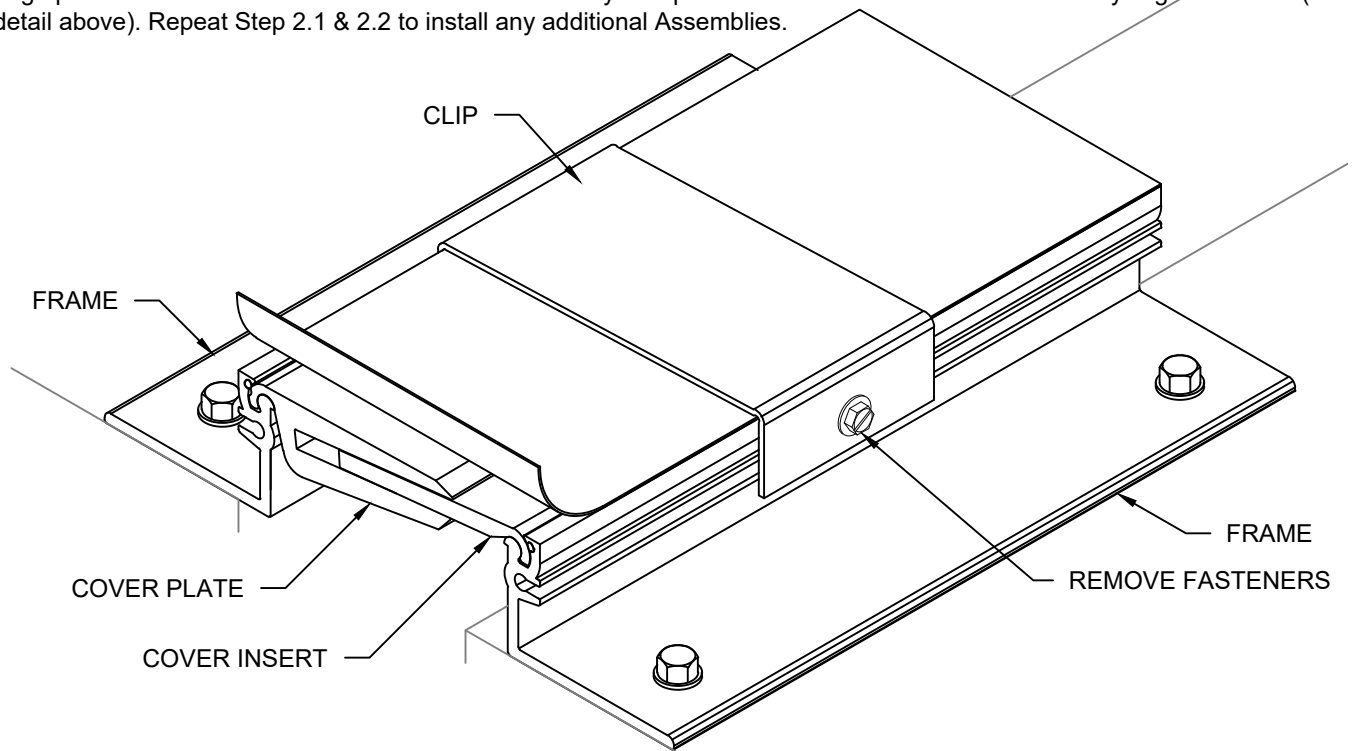

- 2.4) Begin installation of the Floor to Floor Expansion Joint Cover (offset for floor to wall transition) by placing a length of the Assembly over the joint. Cut to the appropriate length if needed.
- 2.5) Refer to Step 1 on Page 6 for Frame location dimensions and mark locations on the slab/blockouts.
- 2.6) Align Assembly and using the holes in the Frame as a template, mark the locations for the CS supplied anchors approx. 6"(152.40mm) from ends and 9"(228.6mm) o.c., max.
- 2.7) Remove Assembly and drill holes for CS supplied anchors in accordance to manufacturer's guidelines.
- 2.8) Place Assembly back over joint and attach using the CS supplied anchors per manufacturer's guidelines.
- 2.9) if additional Floor to Floor Assemblies are required, cut as necessary and use Alignment Pins.
- 2.10) Remove Clips from Expansion Joint Cover Assembly.

# STEP 4

## COMPLETE INSTALLATION

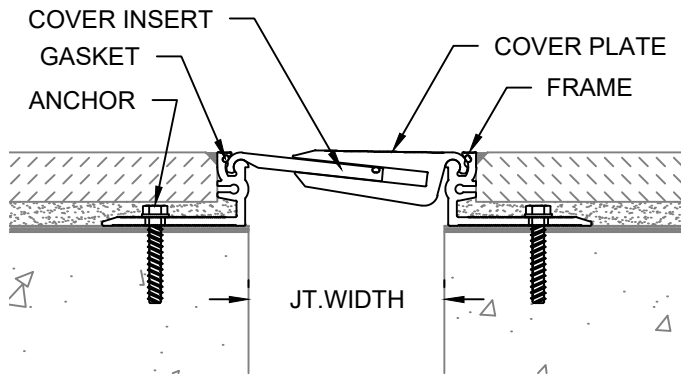

FLOOR TO FLOOR  
CONCRETE SLAB OPTION

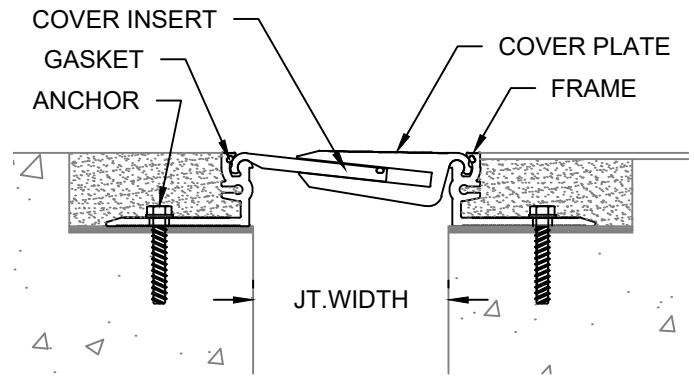

FLOOR TO FLOOR  
BLOCKOUT OPTION

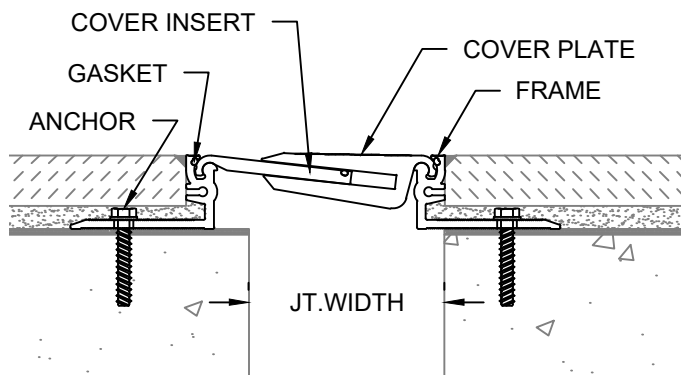

FLR-FLR TO FLR-WALL  
CONCRETE SLAB OPTION

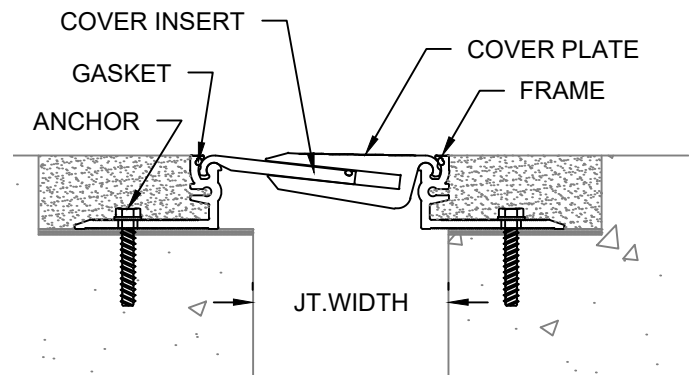

FLR-FLR TO FLR-WALL  
BLOCKOUT OPTION

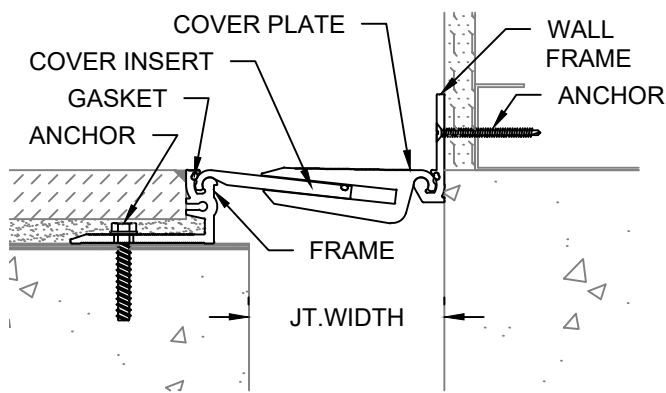

FLOOR TO WALL  
CONCRETE SLAB OPTION

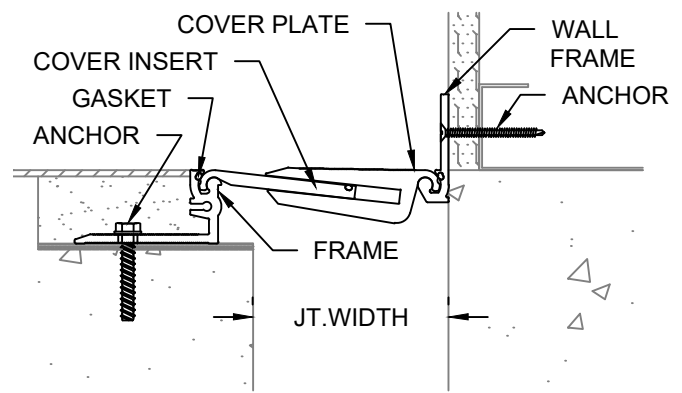

FLOOR TO WALL  
BLOCKOUT OPTION

## STEP 4:

- 4.1) Once all sections of Expansion Joint Cover have been installed, apply a high strength, non-shrink grout into the blockout covering all fasteners as shown above. Either fill flush with top of Frames or Floor Finish (see details above). Repeat this step on the opposite side of the joint.
- 4.2) When installation of the CS Floor Expansion Joint Cover has been completed remove the protective film from the Assemblies, remove all residue and foreign matter from the area and joint cover.
- 4.3) Clean the CS Joint Cover and adjoining surfaces with proper cleaner.
- 4.4) Protect the Joint Cover until the Architect's final inspection.



# TRANSITIONS:

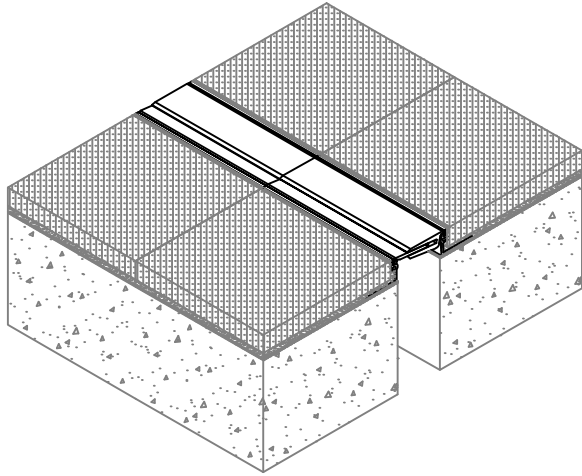

FLR-FLR BUTT

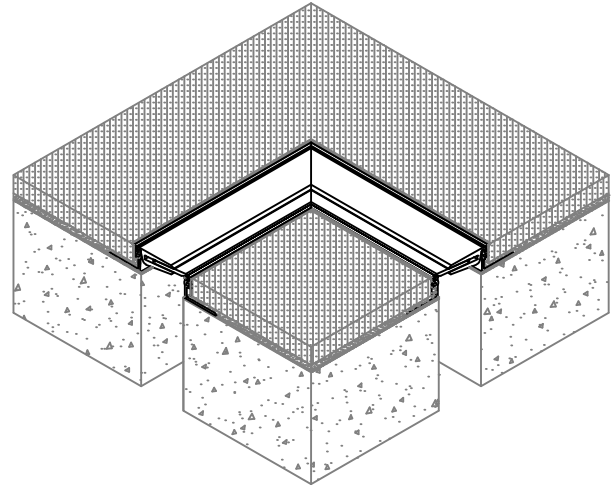

FLR-FLR 90°

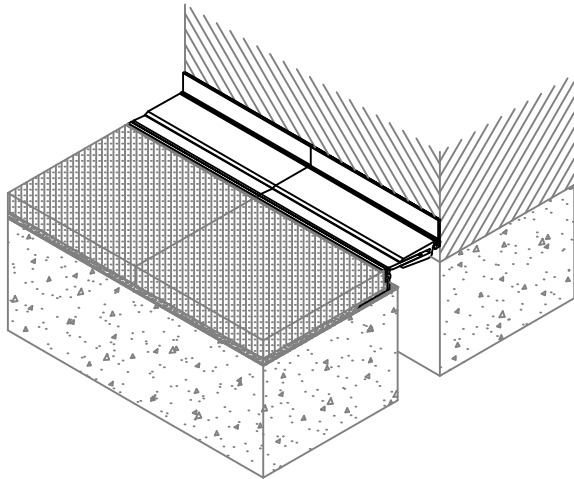

FLR-WALL BUTT

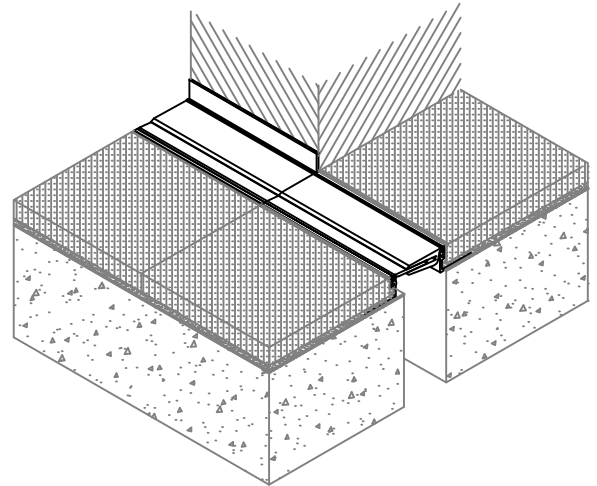

FLR-FLR TO FLR-WALL