

COLOR: \_\_\_\_\_  
 TOP RAIL WOOD SPECIES: \_\_\_\_\_  
 TOP RAIL WOOD FINISH: \_\_\_\_\_  
 BOTTOM RAIL WOOD SPECIES: \_\_\_\_\_  
 BOTTOM RAIL WOOD FINISH: \_\_\_\_\_  
 \*BRACKETS: \_\_\_\_\_  
 \*END CAPS: \_\_\_\_\_  
 COLOR TO BE SELECTED FROM ONE OF CS STANDARD COLORS.  
 \*BRACKETS/CAPS/CORNERS ARE AVAILABLE WITH AN OPTIONAL POWDER COAT FINISH. PLEASE ADVISE POWDER COAT FINISH IF REQUIRED.  
 STAINLESS STEEL END CAPS AND OUTSIDE CORNERS ALSO AVAILABLE.

TOTAL L/F REQ'D	LEFT END CAPS	RIGHT END CAPS	O.S. REQ'D

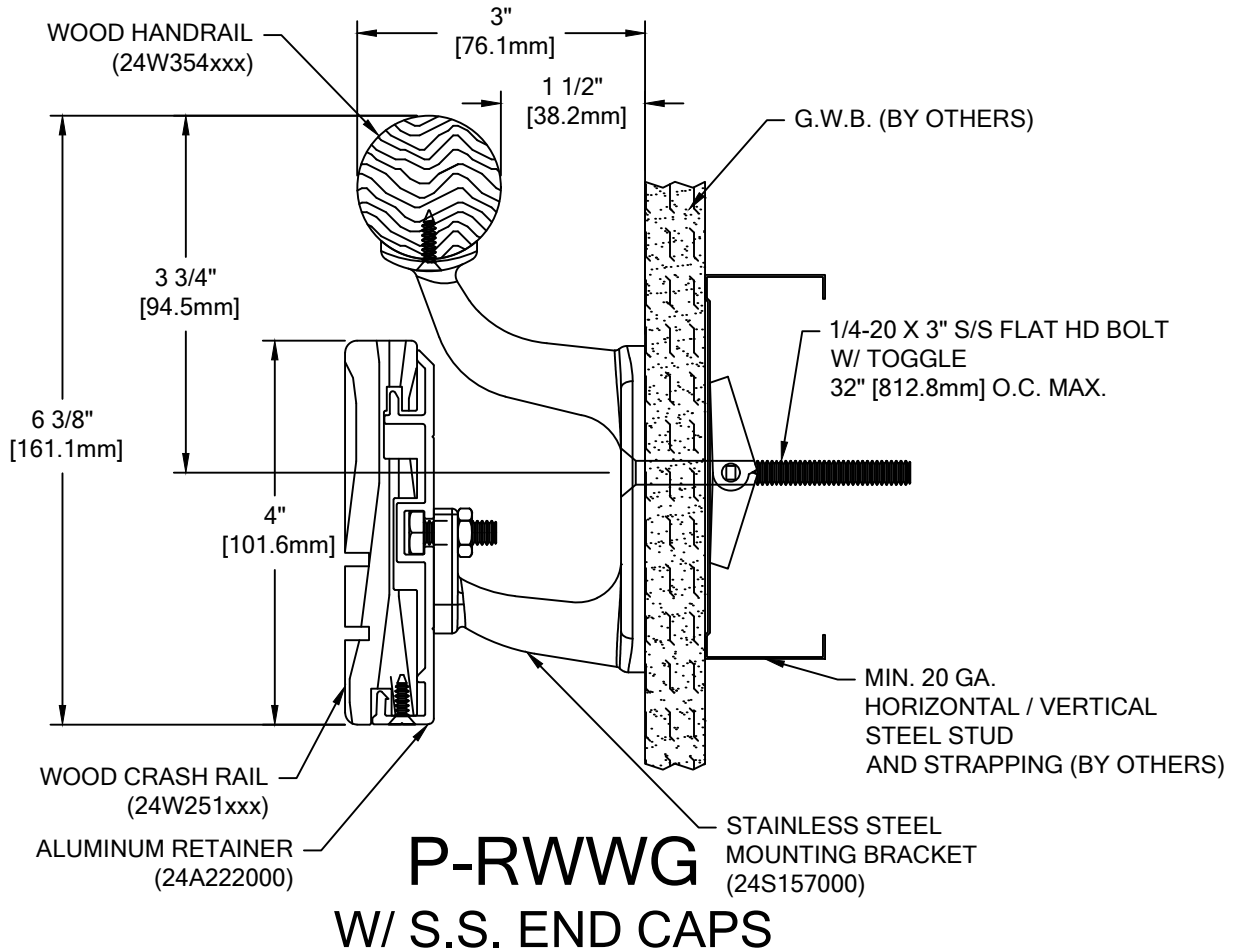

WALL CONDITION	SPECIFIED FASTENER	DRILL DIAMETERS		CS PART NUMBER
		WALL	RETAINER	
STEEL STUD/GYPSUM WALL	1/4-20 X 3" S/S FLAT HEAD BOLT WITH TOGGLE	3/4"	N/A	90H184002
CONCRETE/CONC. BLOCK	1/4" X 1 3/4" S/S FLAT HEAD MASONRY ANCHOR	3/16"	N/A	90H390000
WOOD STUD/GYPSUM WALL	#14 X 3" S/S PHILLIPS FLAT HEAD WOOD SCREW	7/32"	N/A	90H538004
20 GA. STEEL STUD/GYPSUM WALL (OSHPD)	1/4-20 X 3" S/S FLAT HEAD BOLT 1/4" TOGGLER WING 3M MOLDABLE FIRE PUTTY	1/2"	N/A	90H063002 90H062004 90M012000
16 GA. MIN STEEL STUD AND 16 GA. MIN STEEL STRAPPING / GYPSUM WALL (CONSTRUCTION REQUIRED) (TEK SCREWS)	#14 X 3" PHILLIPS FLAT HEAD SELF DRILLING S/S TEK SCREW	N/A	N/A	90H230003

<b>PROJECT:</b>	<b>REVISION:</b>
<b>JOB NO.:</b>	<b>F&amp;F:</b>
<b>CUSTOMER:</b>	<b>DATE:</b>
<b>REP:</b>	<b>SHEET NO:</b>
<b>DRAWN BY:</b>	

**CS Acrovyn™**  
 Hughesville, PA | 800.233.8493 | 570.546.5941  
 Mississauga, ON | 888.895.8955 | 905.274.3611  
[www.c-sgroup.com](http://www.c-sgroup.com)  
 © Copyright 2019 Construction Specialties, Inc.