

CORNER GUARD:
FINISH: _____
GAUGE: _____
TYPE: _____
 CORNER GUARDS SUPPLIED IN STANDARD 16 GAUGE, TYPE #304 ALLOY WITH #4 SATIN FINISH.
 OPTIONAL POWDER COAT FINISHES ARE AVAILABLE. PLEASE ADVISE OPTIONAL POWDER COAT FINISH IF REQUIRED.
 OPTIONAL GAUGE (14,18, 20) AND ALLOY TYPES (#316, #430) AVAILABLE. PLEASE ADVISE OPTIONAL GAUGE AND ALLOY TYPE IF REQUIRED.

UNITS REQ'D	UNIT HEIGHT	ANGLE	LEG LENGTH	NOSE RAD.

NOTES:

- CORNER GUARDS ARE SHIPPED WITH A PROTECTIVE STRIPPABLE COATING.
- CO-8 CORNER GUARDS HAVE A STANDARD ANGLE OF 90°, LEG LENGTH OF 3 1/2" [89.0mm] AND A STANDARD NOSE RADIUS OF 3/16" [4.8mm]. CO-8M CORNER GUARDS HAVE A STANDARD ANGLE OF 135°, LEG LENGTH OF 3 1/2" [89.0mm] AND A STANDARD NOSE RADIUS OF 3/16" [4.8mm]. PLEASE ADVISE IF A DIFFERENT LEG LENGTH, ANGLE OR BULL NOSE RADIUS (AVAILABLE IN 1/2" [12.7mm] AND 3/4" [19.15mm] RADIUS) IS DESIRED.
- CORNER GUARDS HAVE A MINIMUM LEG LENGTH OF 2" [50.8mm] AND MINIMUM NOSE RADIUS OF 3/16" [4.8mm].
- ANGLES ONLY AVAILABLE BETWEEN 45° - 178°.
- *CORNER GUARDS CAN BE USED AT FULL OR PARTIAL HEIGHTS. PLEASE ADVISE SPECIFIED UNIT HEIGHT OF CORNER GUARD.*

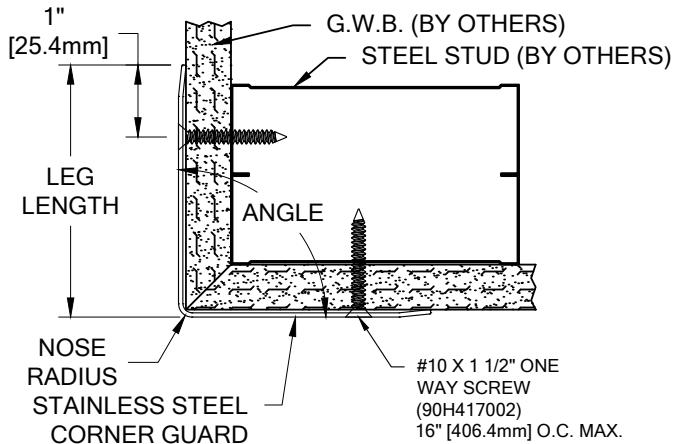

MODEL: CO-8

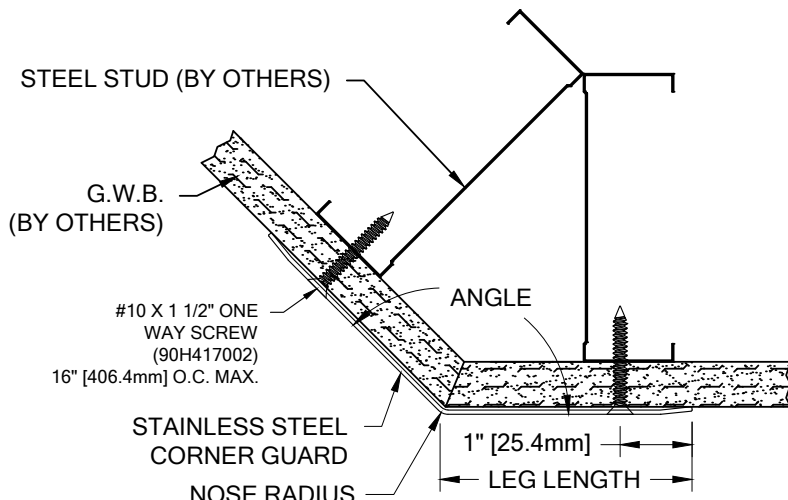

MODEL: CO-8M

CO-8 SERIES CORNER GUARD

WITH TAMPER RESISTANT FASTENERS

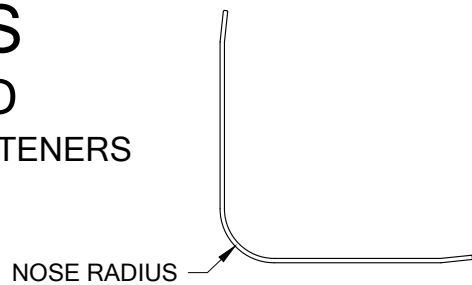

BULL NOSE RADIUS

Hughesville, PA | 800.233.8493 | 570.546.5941
 Mississauga, ON | 888.895.8955 | 905.274.3611
www.c-sgroup.com
 © Copyright 2018 Construction Specialties, Inc.

PROJECT:	REVISION:
JOB NO.:	F&F:
CUSTOMER:	
REP:	DATE:
DRAWN BY:	SHEET NO:
