

# MODEL RFA/RFWA-300/400 INSTALLATION INSTRUCTIONS

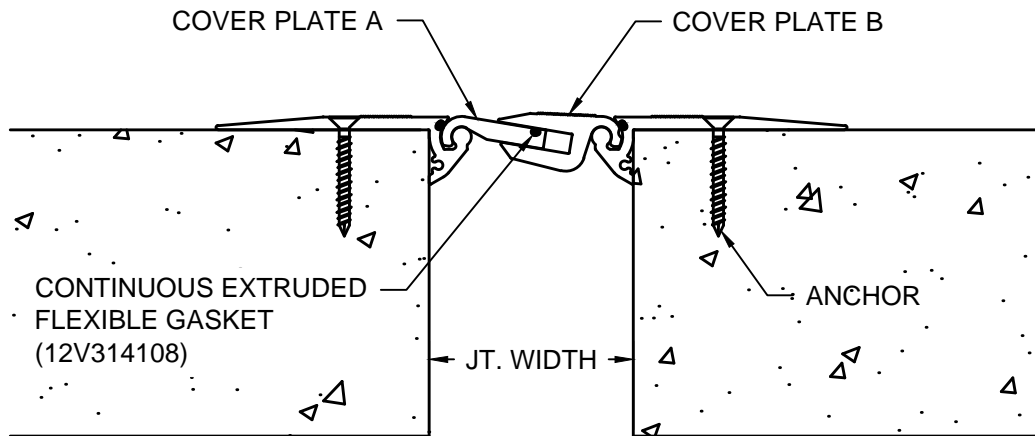
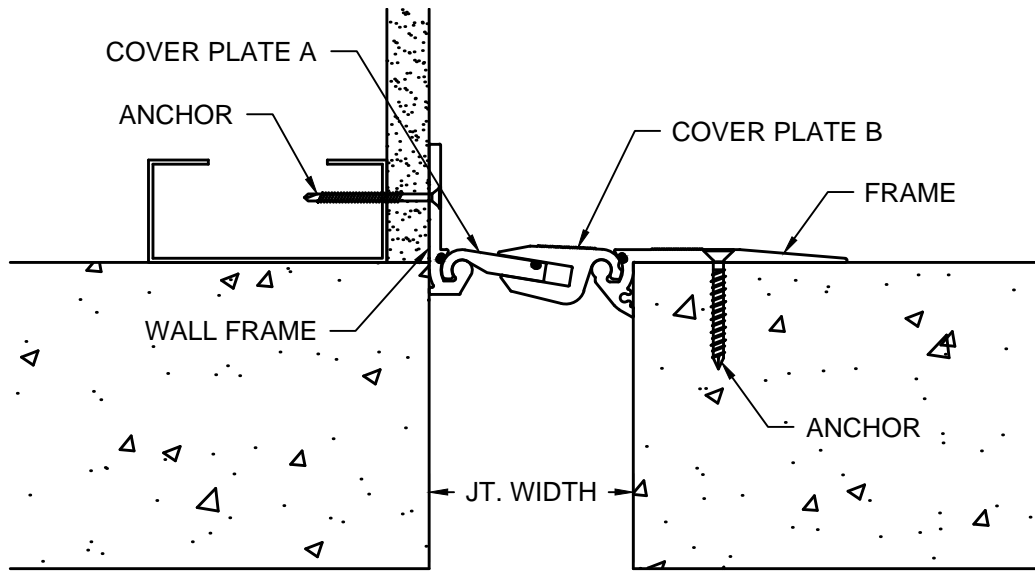

## IMPORTANT INFORMATION

Prior to the commencement of installation, all materials **MUST** be inspected for damage. Any damage must be reported to CONSTRUCTION SPECIALTIES, INC., as soon as possible, so that replacement materials may be furnished without delay.

All work must be completed as per Architect's Approved "Shop Drawings", and in accordance with these Installation Instructions. When installation is complete, all materials must be protected from damage until the Architect's FINAL INSPECTION.

### IMPORTANT:

**READ THROUGH ALL INSTRUCTIONS PRIOR TO STARTING INSTALLATION**

All materials should be arranged in the order that they are to be installed. All hardware required for each portion of the work should be placed with the appropriate materials.

Please review all Approved Shop Drawings and this document to familiarize yourself with all the details and components of this assembly.

11/5/13



**Construction Specialties™**

6696 Route 405 Highway, Muncy PA 17756  
(800) 233-8493 Fax (570) 546-5169 [www.c-sgroup.com](http://www.c-sgroup.com)

This document is the property of Construction Specialties, Inc. and contains CONFIDENTIAL PROPRIETARY INFORMATION that is not to be disclosed to third parties and is not to be used without approval in writing from Construction Specialties, Inc.

Notes

Before beginning installation, review the architectural drawings and approved Construction Specialties Inc. shop drawings to familiarize yourself with the joint cover models and locations.

Check all of the joint cover components to confirm that the correct joint cover model and size have been received. Also, check for materials that may have been damaged during shipping. Report all incorrect and/or damaged components to C/S at 800-233-8493.

Read through all the steps of these instructions prior to beginning work.

# STEP 1

PREPARE FLOOR SLAB

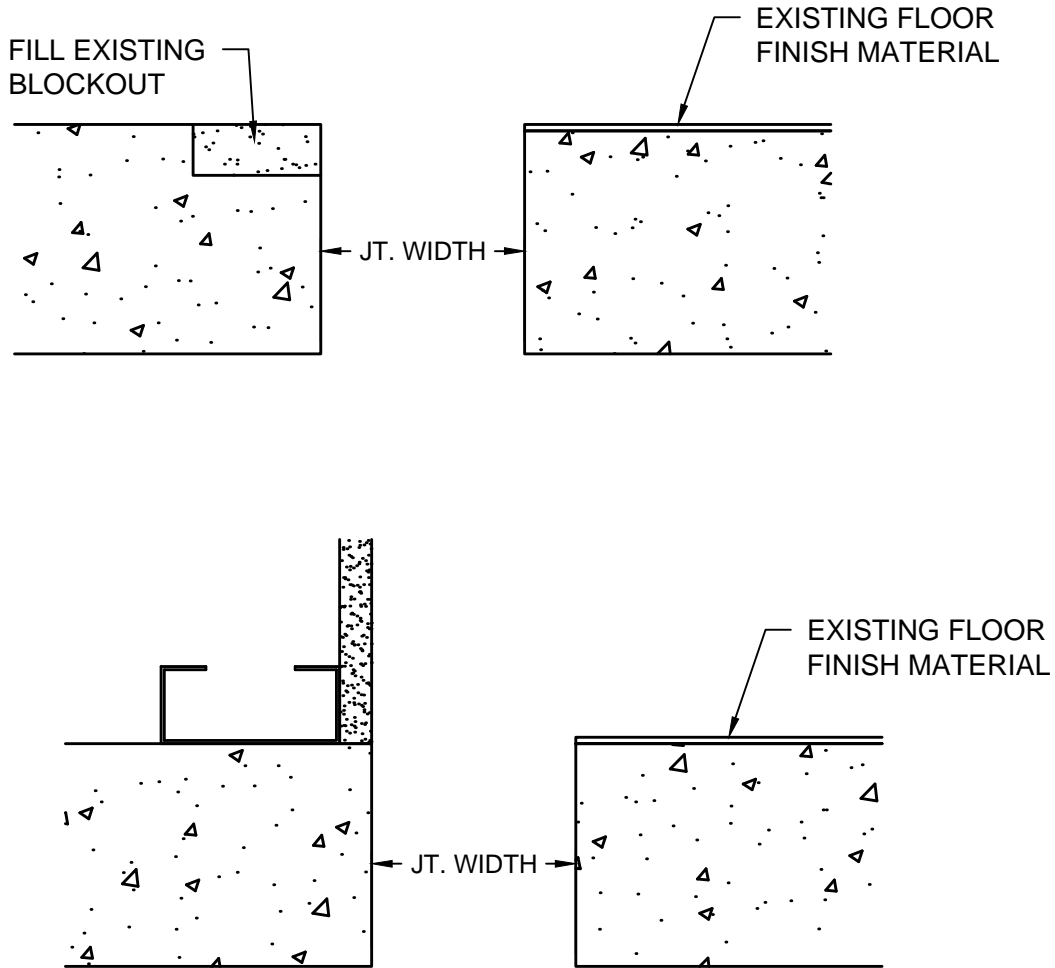

Step 1:

1.1) Where necessary, prepare the floor slab for installation of the joint cover:

- Fill any existing joint cover blockout to level and smooth.
- RFA joint covers can be mounted over existing floor finish materials or direct to concrete slab.

# STEP 2

PREPARE COVER FOR INSTALLATION

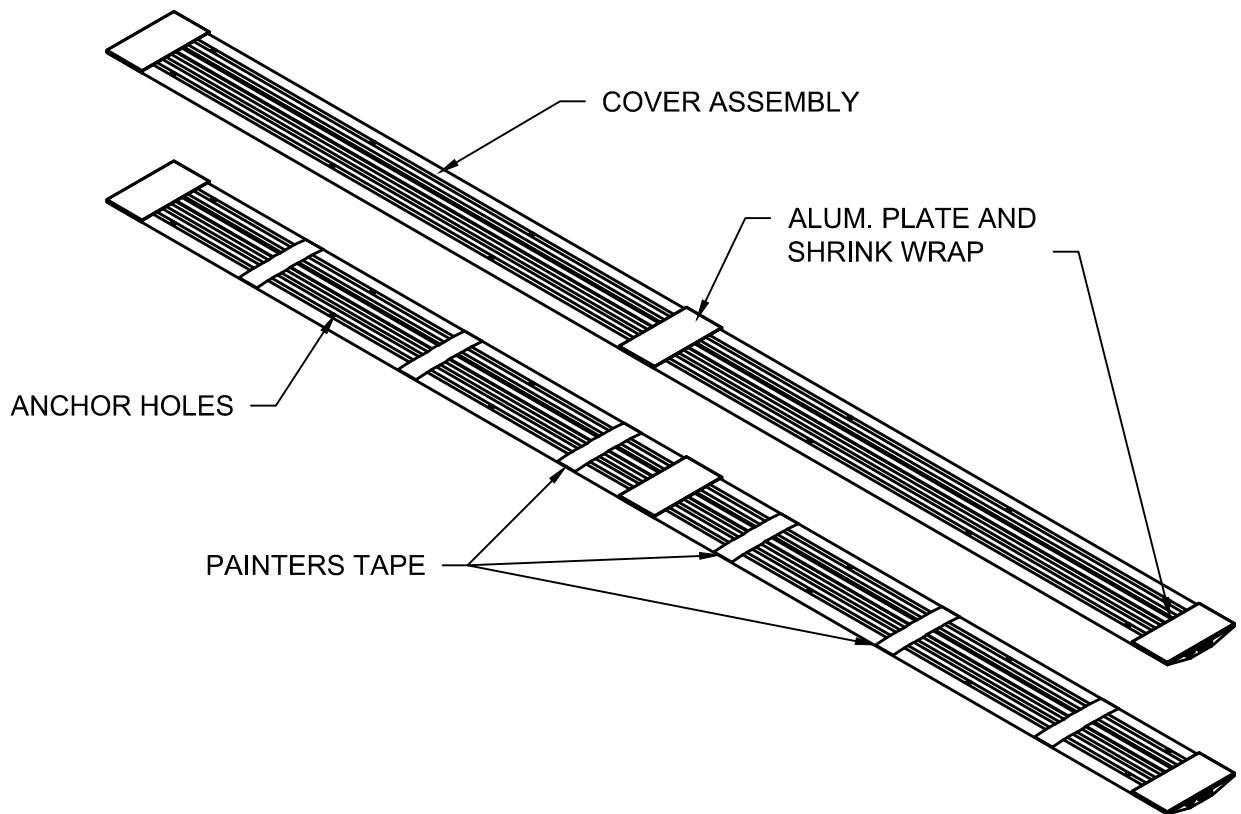
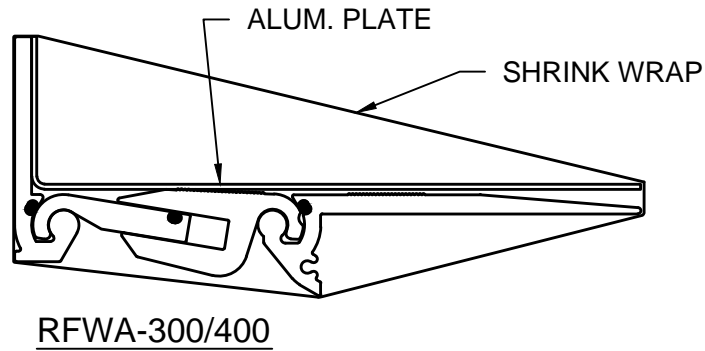
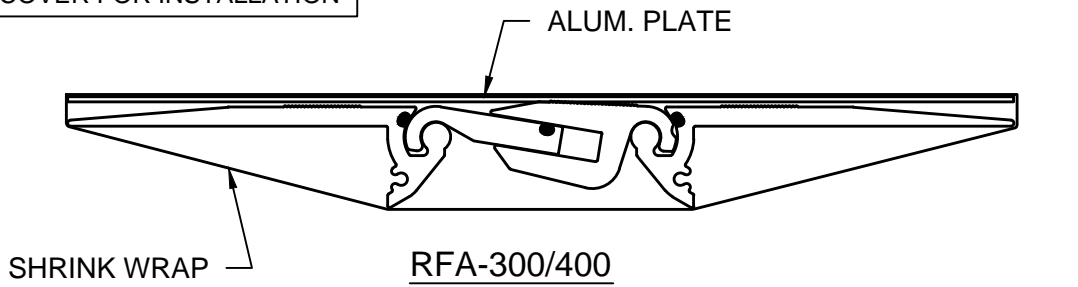

## Step 2:

Note: The RFA/RFWA-300/400 covers have been factory assembled and bound together with aluminum plate spacers and shrink wrap plastic to facilitate shipment and initial handling. When the packaging is removed the assembly may come apart and individual components may slide linearly in relation to each other.

2.1) Before removing the packaging, place the assembly onto a floor or other flat surface. Apply several strips of painter's tape or masking tape, between anchor holes, across the full width of the cover assembly. The tape will help to hold the assembly and components when the packaging is removed.

2.2) Carefully cut the shrink wrap and remove the shrink wrap and alum. spacer plates.

Continued next sheet.

# STEP 2 Cont.

## PREPARE COVER FOR INSTALLATION

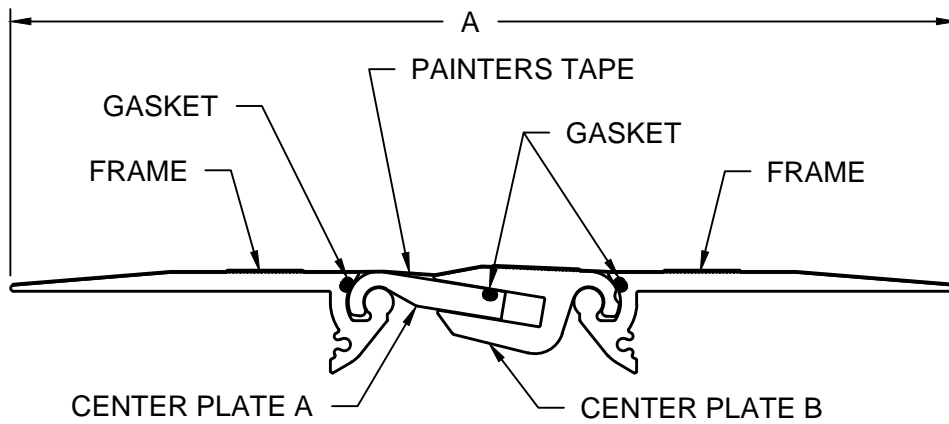

RFA-300/400

MODEL	DIM. "A"
RFA-300	9 1/4"
RFA-400	10 1/4"

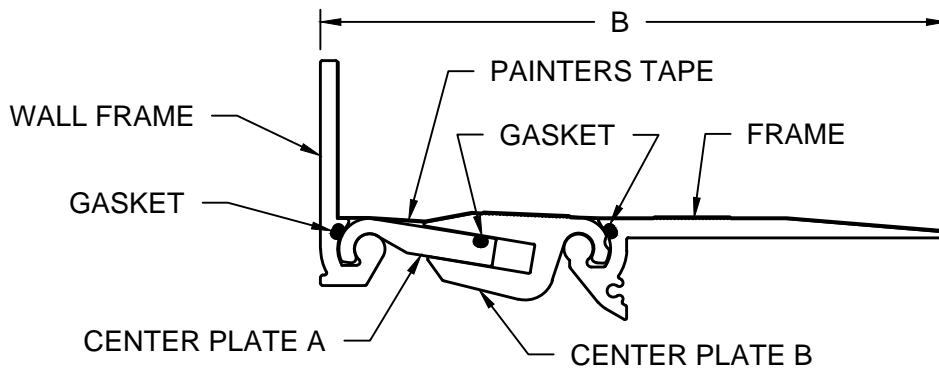

RFA-300/400

MODEL	DIM. "A"
RFA-300	6 1/8"
RFA-400	7 1/8"

### Step 2 Cont.:

Note: If the cover is to be cut to length, determine if the cut can be safely made with the cover assembled with the field equipment available. Note: C/S recommends disassembling the cover and cutting the pieces individually.

If cutting the assembly:

2.3) Measure the length of cover needed for the installation.

2.4) Assure that the ends of the individual components are aligned at one end. Measuring from this end, measure mark and cut the assembly to the required length.

If cutting individual components:

2.3) Measure the length of cover needed for the installation.

2.4) Disassemble that joint cover by sliding the pieces apart lineally. It is not necessary to remove the rubber gasket.

2.5) Measure, mark and cut each component to the required length. Debur the cut edges before re assembling.

2.6) Slide the assemblies back together per the details above. Set the exposed surface dimension as shown and replace the strips of painters tape as previously instructed.

# STEP 3

## FLOOR COVER INSTALLATION

RFA-300/400

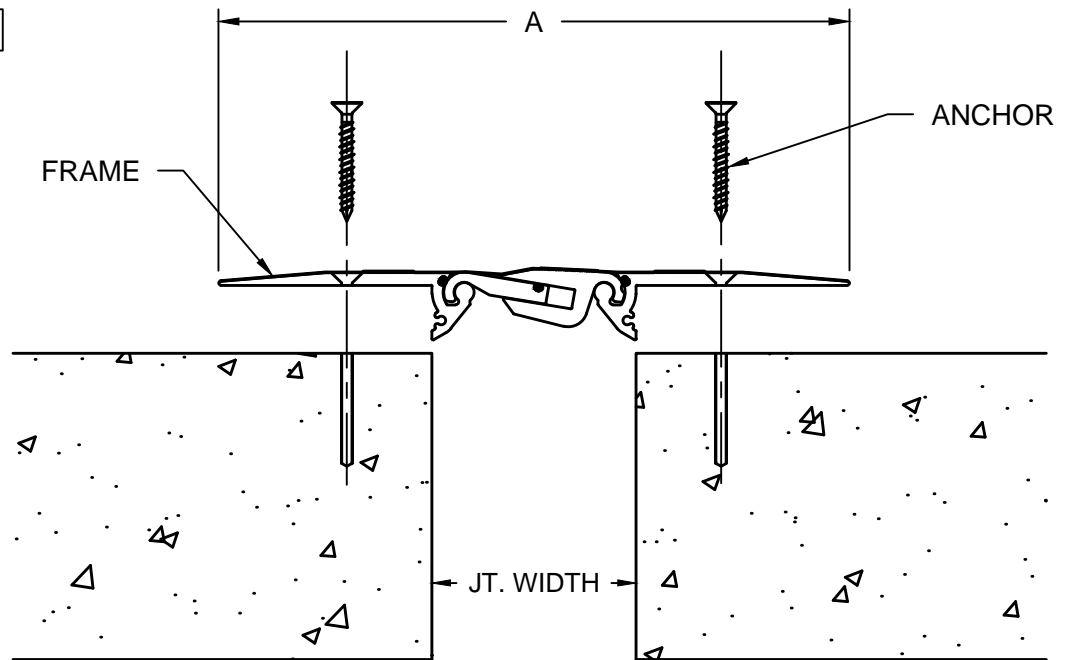

RFWA-300/400

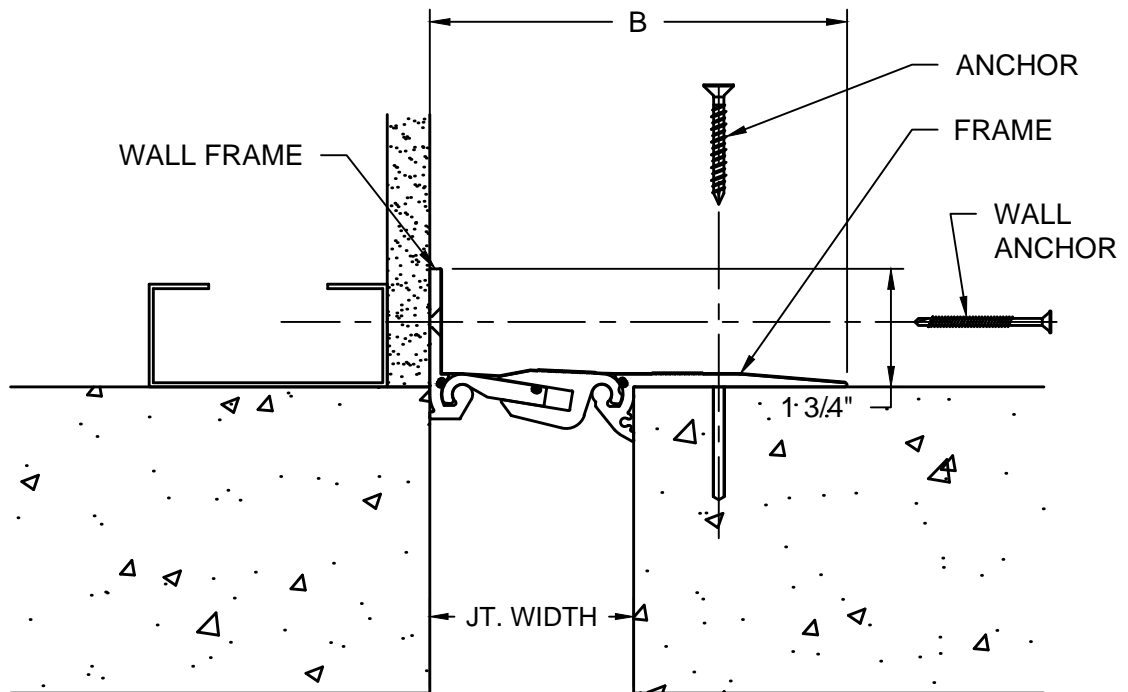

### STEP 3:

#### Note:

If a C/S Fire Barrier is to be installed in the joint, please review the Fire Barrier Installation Instructions supplied, and if required install the Fire Barrier **BEFORE** installation of C/S Seismic Expansion Joint Assemblies. If a Vapor Barrier is to be installed in the joint, please review the Vapor Barrier Installation Instructions supplied, and if required install the Vapor Barrier **BEFORE** installation of C/S Seismic Expansion Joint Assemblies.

3.1) Begin installation of the Cover Assembly by centering the Assembly over the joint. (Note: Assure that the cover is at the indicated width dimension. This is important to maintain expansion and compression movement capability from the installed width.) If the dimension needs adjusted, lift the tape strips from one side to the center and adjust the width. Reposition the tape.

3.2) Seat the assembly onto the floor surface. Using the the Frame as a template, mark the locations of each of the C/S anchor holes.

3.3) Remove Assembly and drill holes for C/S supplied anchors in accordance with the anchor manufacturer's guidelines.

3.4) Place the Assembly back over the joint and attach using the C/S supplied anchors per manufacturer's guidelines.

FOR RFWA ONLY

3.5) Install the C/S supplied wall anchors.

# STEP 4

INSTALL ADDITIONAL LENGTHS

RFA-300/400

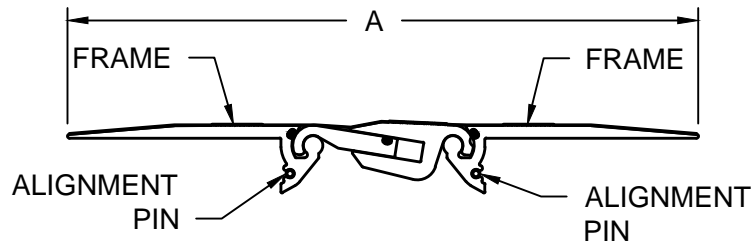

RFWA-300/400

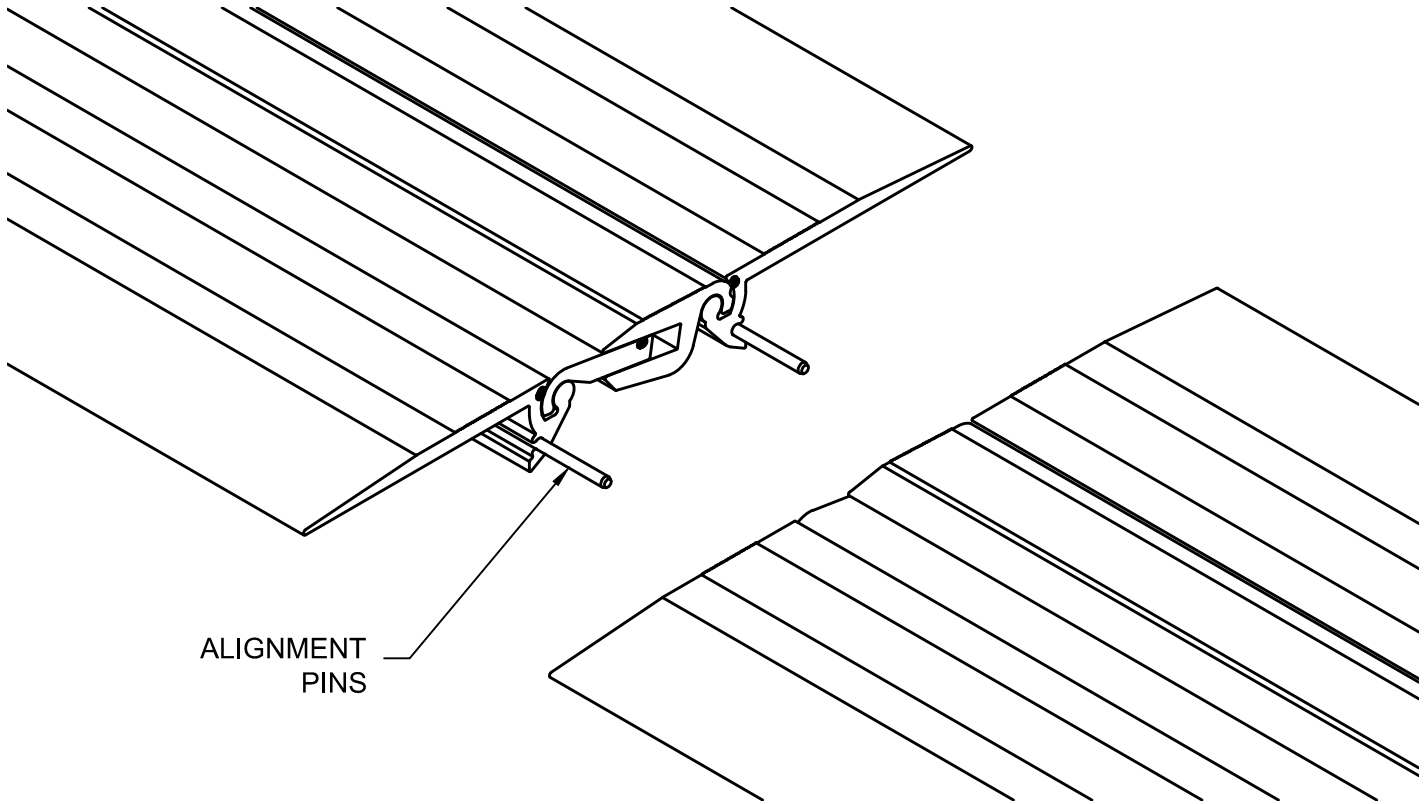
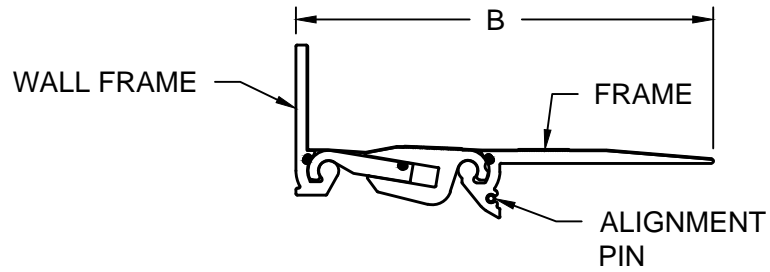

## STEP 4:

### Note:

When additional lengths of cover are required to make up the full run length, use alignment pins to maintain alignment from one assembly to the next. Leave a 1/16" gap between assemblies for thermal expansion.

- 4.1) Follow the instructions on pages 4 and 5 to prepare the cover for installation.
- 4.2) Before placing the cover for anchoring to the floor (step 3.4) insert a C/S supplied Alignment Pin into the the slot at the lower portion of each Frame.
- 4.3) Using a hammer, tap the pin about 2/3 of the way into the slot.
- 4.4) Place Assembly over the joint and insert the extended end of the pins into the slot of the previously installed floor cover.
- 4.5) Anchor the cover as instructed.

# STEP 5

COMPLETE INSTALLATION

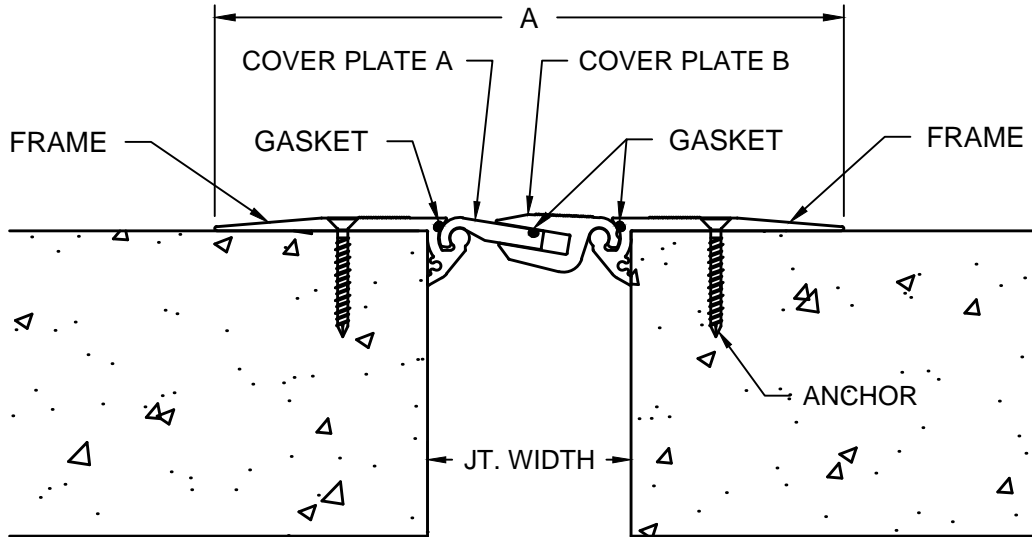

RFA-300/400

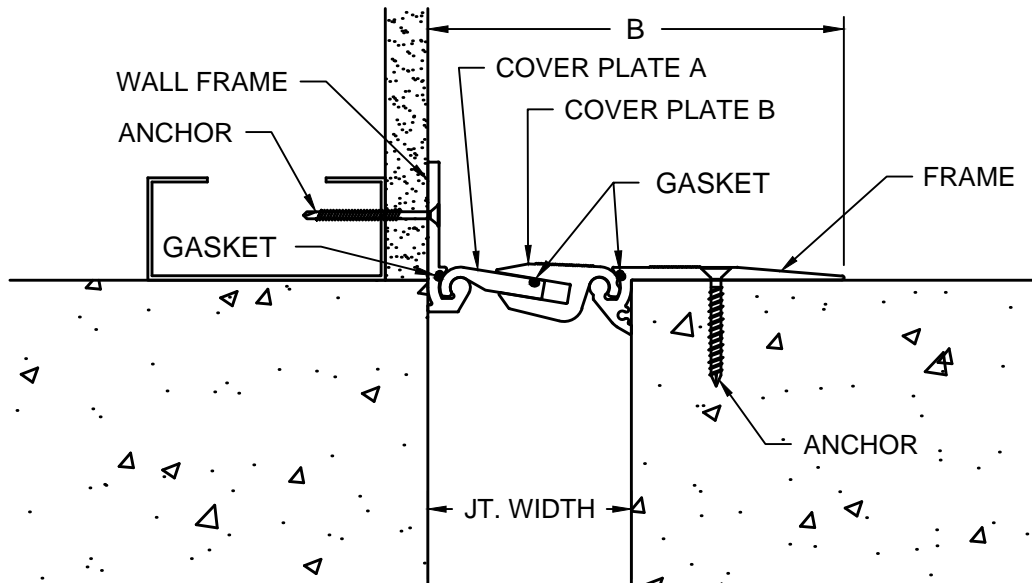

RFWA-300/400

## STEP 5:

- 5.1) Once the Cover Assemblies have been installed for the full run, remove the painters tape and clean the surface of the cover to remove any residue that may have been left behind by the tape.
- 5.2) Protect the Joint Cover until the Architect's final inspection.