

# MODEL SJPF & SJPFW 400 THRU 800 INSTALLATION INSTRUCTIONS

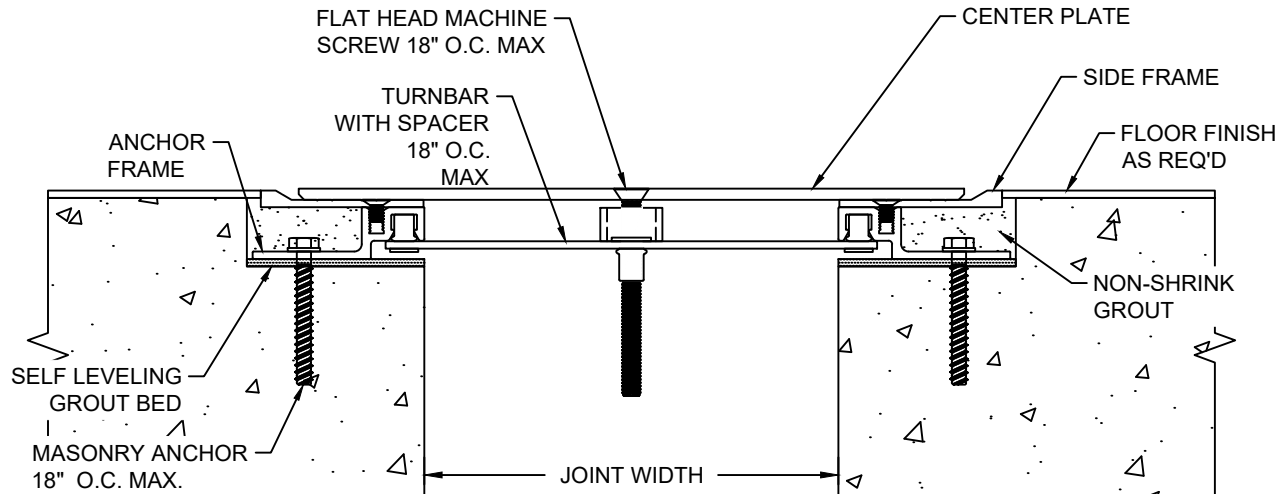

MODEL-SJPF

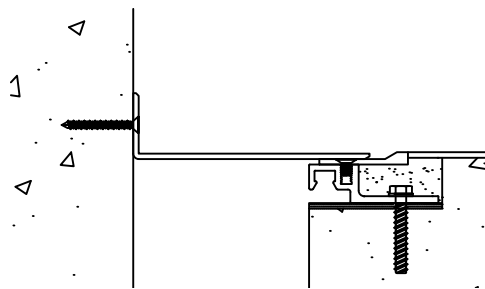

MODEL-SJPFW 400-600

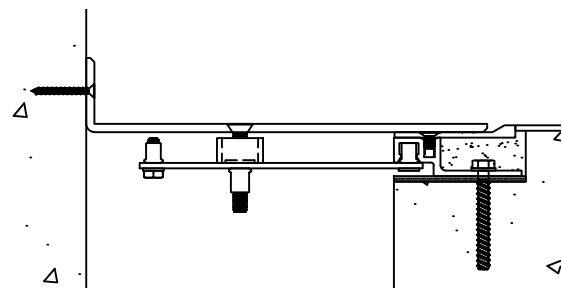

MODEL-SJPFW 700-800

## IMPORTANT INFORMATION

Prior to the commencement of Installation, all materials MUST be inspected for Damage. Any damage must be reported to CONSTRUCTION SPECIALTIES, INC., as soon as possible, so that replacement materials may be furnished without delay.

All work must be completed as per Architect's Approved "Shop Drawings", and in accordance with these Installation Instructions. When installation is complete, all materials must be protected from damage until the Architect's FINAL INSPECTION.

All materials should be arranged in the order that they are to be installed. All hardware required for each portion of the work should be placed with the appropriate materials.

Please review all Approved Shop Drawings and this Document to familiarize yourself with all the details and components of this assembly.

### IMPORTANT:

READ THROUGH ALL INSTRUCTIONS PRIOR TO STARTING INSTALLATION

4/2/25



**Construction Specialties®**  
www.CSgroup.com

6696 Route 405 Highway, Muncy, PA 17756  
Phone: (800) 233-8493 / Fax: (570) 546-8022

This document is the property of Construction Specialties, Inc. and contains PROPRIETARY INFORMATION that is not to be disclosed to third parties and is not to be used without approval in writing from Construction Specialties, Inc.

© Copyright 2016 Construction Specialties, Inc.

Notes:

Before beginning installation, review the architectural drawings and approved Construction Specialties Inc. shop drawings to familiarize yourself with the appropriate joint cover models and locations.

Check all of the joint cover components to confirm that the correct joint cover model and size have been received. Also, check for materials that may have been damaged during shipping. Report all incorrect and/or damaged components to CS at 800-233-8493.

Read through all the steps of these instructions prior to beginning work.

# STEP 1

## PREPARE BLOCKOUTS

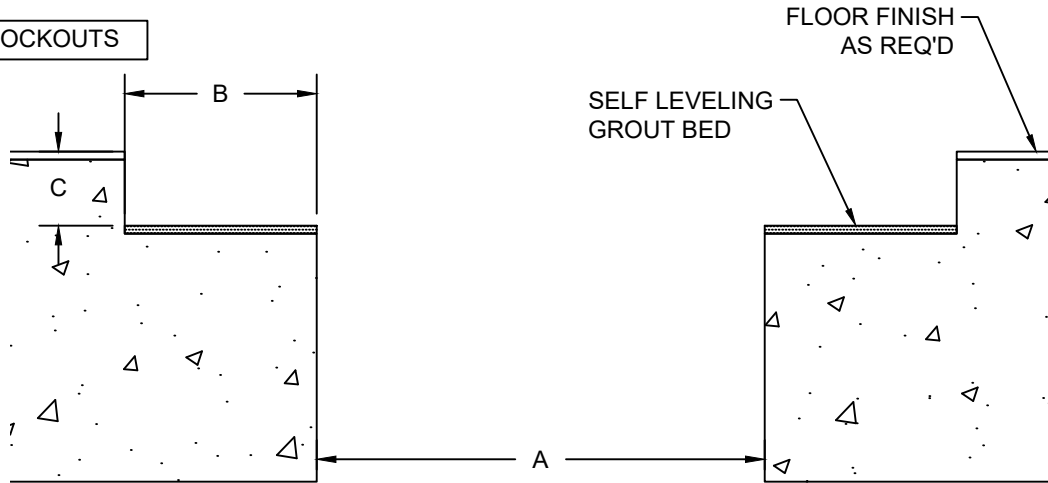

MODEL-SJPF

BLOCKOUT DIMENSIONS		
DIM. A	DIM. B	DIM. C
4" - 7"	3 "	1 1/8"
8"	3 3/8"	1 1/4"

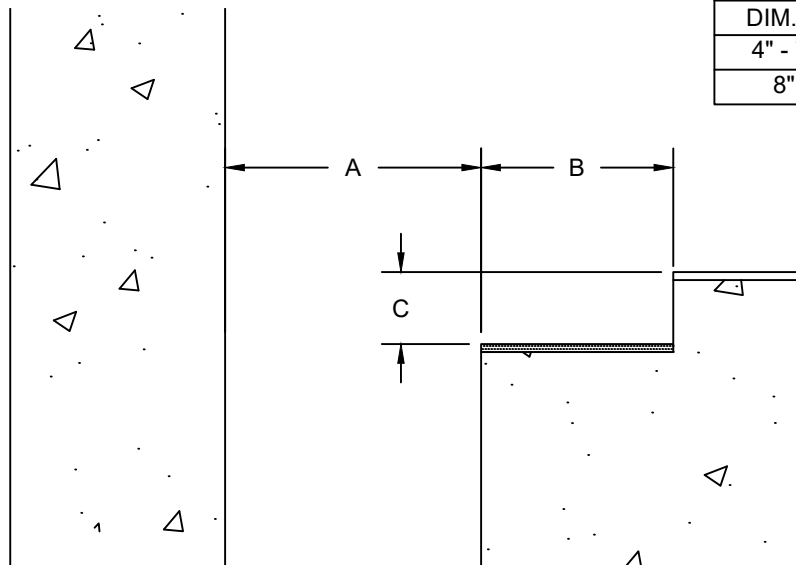

MODEL-SJPFW

- 1.1) The blockouts must be prepared to receive the joint cover.
  - The blockout width (Dim. B) will vary with models as indicated above or as noted on the CS shop drawings.
  - The blockout depth will typically be 1-1/8" (SJPF/W 400-700) or 1-1/4" (SJPF/W-800).
  - Blockout depth may be adjusted as needed to accommodate a floor finish material when req'd and as indicated on the architectural drawings and/or CS shop drawings.
  - It is recommended that the blockout be formed a minimum of 1/8" deeper to allow the blockouts to be leveled for installation of the joint cover.
  - Apply a self leveling grout to the base of the blockouts to provide a continuous, solid, flat and level base for the joint cover. (Note: The blockouts must be level across the width of the joint.)

# STEP 2

## TURNBAR ASSEMBLY

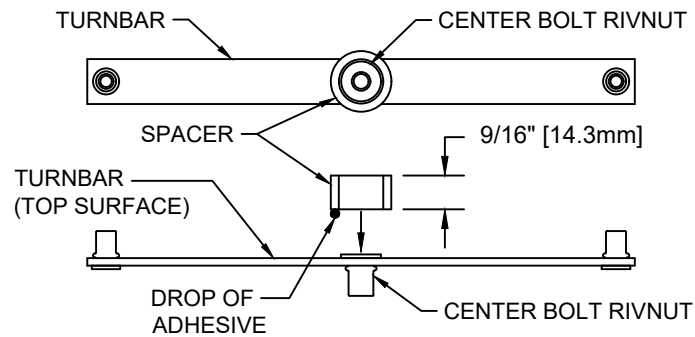

MODEL-SJPF

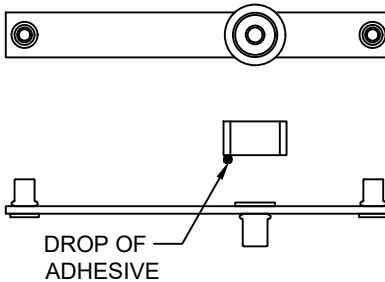

MODEL-SJPFW

- 2.1) Place a small drop of "super glue" adhesive (not supplied) onto one end of a Spacer.
- 2.2) Position the end of the Spacer with the adhesive against the top surface of the Turnbar, centered over the flat head portion of the Center Bolt Rivnut. (See detail above.)
- 2.3) Press firmly for a few seconds until the Spacer is bonded to the Turnbar.

**\*\*Note:**

- If a CS Fire Barrier is to be installed in the joint, please review the Fire Barrier Installation Instructions supplied, and if required install the Fire Barrier **BEFORE** installation of CS Seismic Expansion Joint Aluminum Frames.
- If a Vapor Barrier is to be installed in the joint, please review the Vapor Barrier Installation Instructions supplied, and if required install the Vapor Barrier **BEFORE** installation of CS Seismic Expansion Joint Aluminum Frames.

# STEP 3

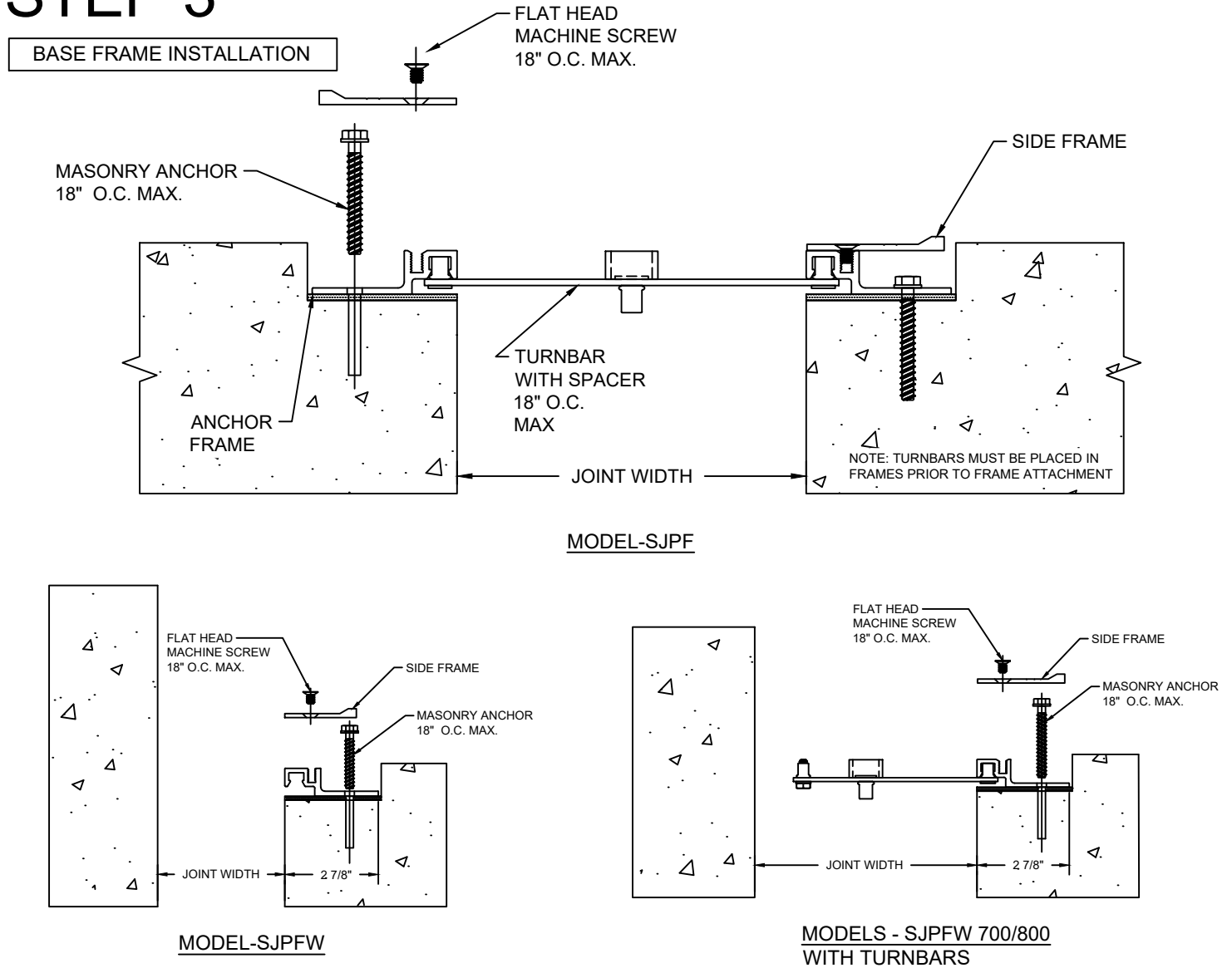

- 3.1) The Anchor Frame is located at 2 7/8" back from the joint edge to the Anchor Frame leg. (See Above) Begin installation of the Anchor Frame by placing a length of Anchor Frame into the blockout. Cut the Anchor Frame to length as needed. The Anchor Frame is to sit level, flat and parallel to the edge of the joint. The Anchor Frame should not overhang the edge of the slab or sit above the top surface of the slab (except to accommodate floor finish).
- 3.2) Using the Anchor Frame as a template, mark the locations in the blockout for the anchor bolts. Remove the Anchor Frame and drill the holes for the anchor bolts. The holes are to be drilled with the appropriate size and type of drill bit as indicated by the manufacturer of the anchor bolts, as supplied by CS.
- 3.3) Place Turnbars 18" O.C. max. into Anchor Frame, reposition and anchor the Anchor Frame to the slab with the CS supplied anchor bolts following the manufacturer's guidelines. Note: All Turnbars should be angled in the same direction.
- 3.4) Repeat the installation procedures for any additional lengths of Anchor Frame or the Anchor Frame at the opposite side of the joint if required.
- 3.5) Begin installation of Side Frame by placing a length of the Side Frame onto the Anchor Frame, in the orientation shown above. Cut the Side Frame to length as needed.
- 3.6) Align machine screw holes of the Side Frame with the screw slot of the Anchor Frame. Attach the Side Frame to the Anchor Frame with the CS supplied machine screws.

## Floor to Wall applications:

- 3.7) Same installation procedure as above, Models 1" - 6" have no Turnbars, Models 7" -8" with Turnbars.

# STEP 4

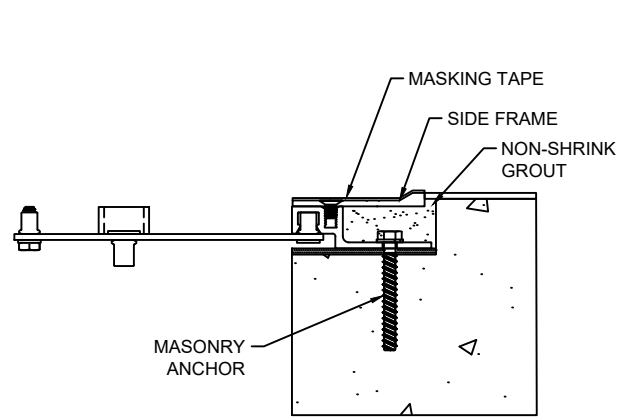
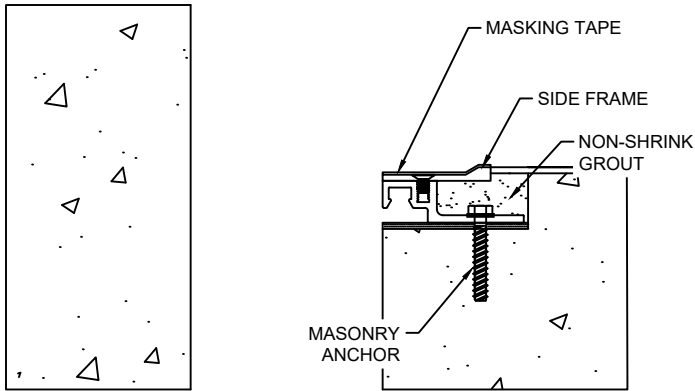
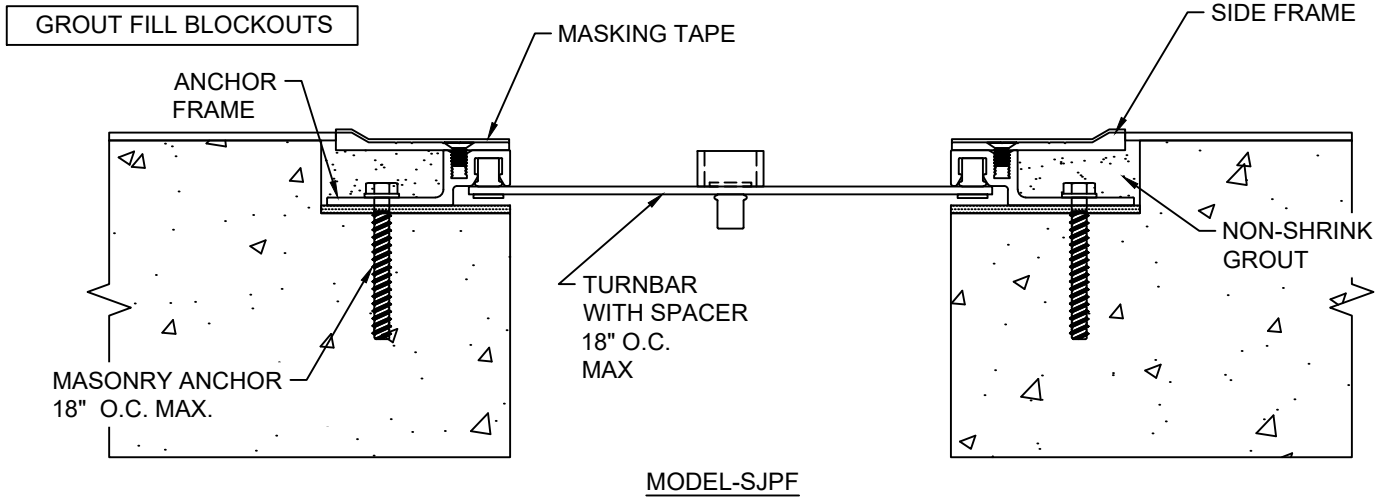

- 4.1) Protect Side Frames with masking tape.
- 4.2) Apply non-shrink grout in blockout (both sides floor to floor SJPF) of the expansion joint. The grout must be poured level with the blockout.
- 4.3) Remove tape from the Side Frames after grouting.

# STEP 5

## CENTER PLATE INSTALLATION

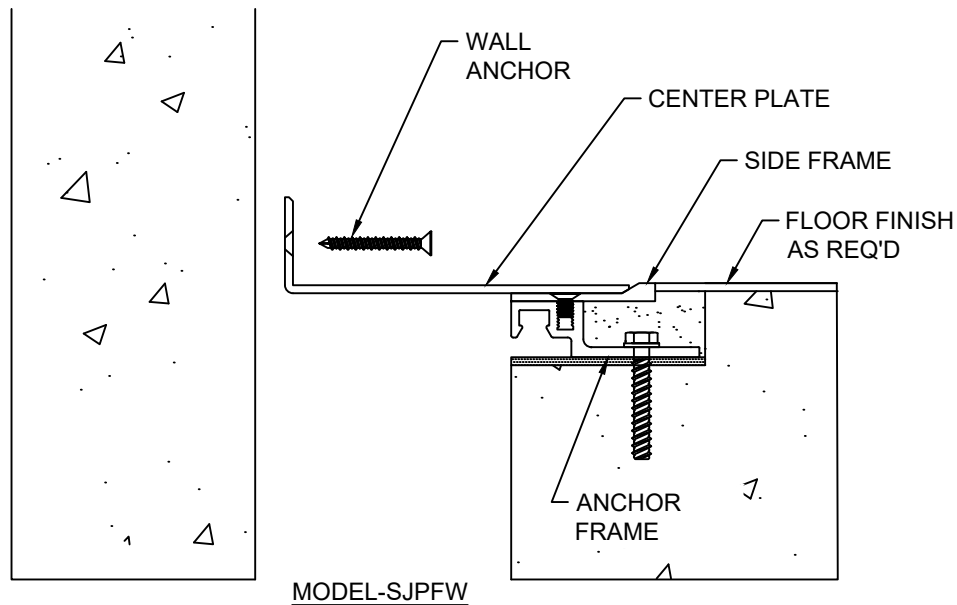
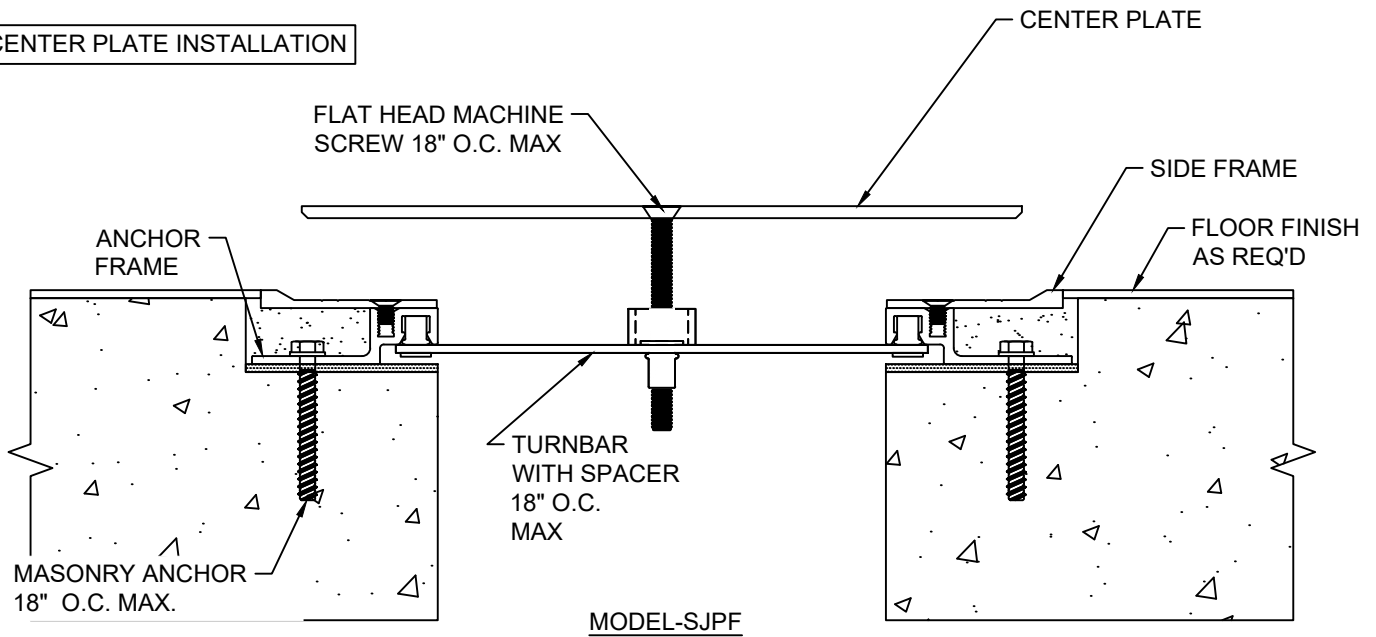

- 5.1) Prepare Center Plate for installation by first cutting the Plate to length as needed.
- 5.2) Position the Center Plate on the Frames over the joint. Align the Turnbars with the holes in the Center Plate and attach using the CS supplied machine screws.
- 5.3) Repeat this installation procedure for any additional lengths of Center Plate.

### Floor to Wall applications: SJPFW 400-600

- 5.4) Place Center Plate on top of Frame and slide vertical leg of the Center Plate against surface of the wall. Attach to wall using the CS supplied wall fasteners at 18" on center maximum.

### SJPFW 700-800 Models with Turnbars:

- 5.5) Position the Center Plate on top of Frame and align the Turnbars with the holes in the Center Plate. Attach Turnbars using the CS supplied machine screw. Place the vertical leg of Center Plate against surface of the wall and attach using the CS supplied wall fastener at 18" on center maximum.
- 5.6) Repeat this installation procedure for any additional lengths of Floor to Wall Center Plates.

# STEP 6

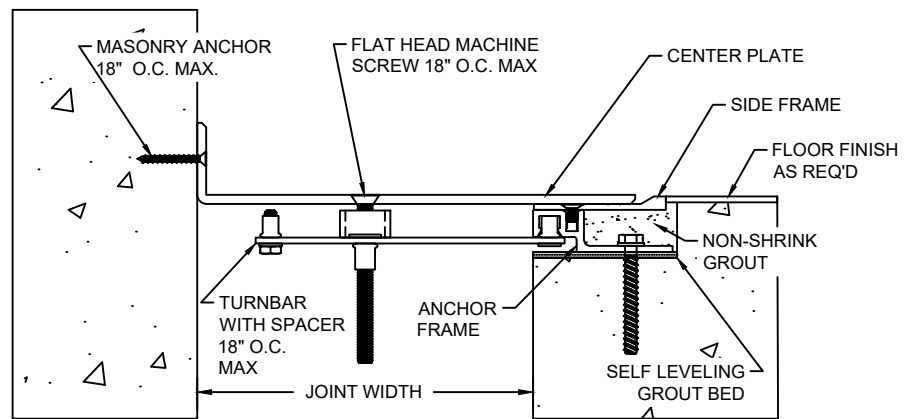
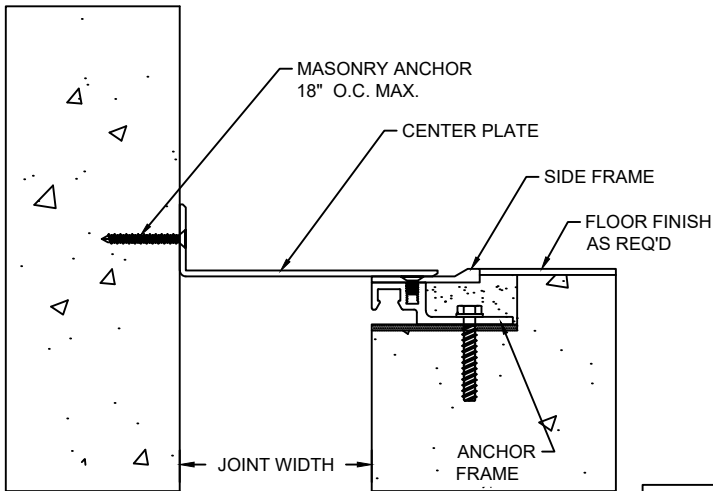
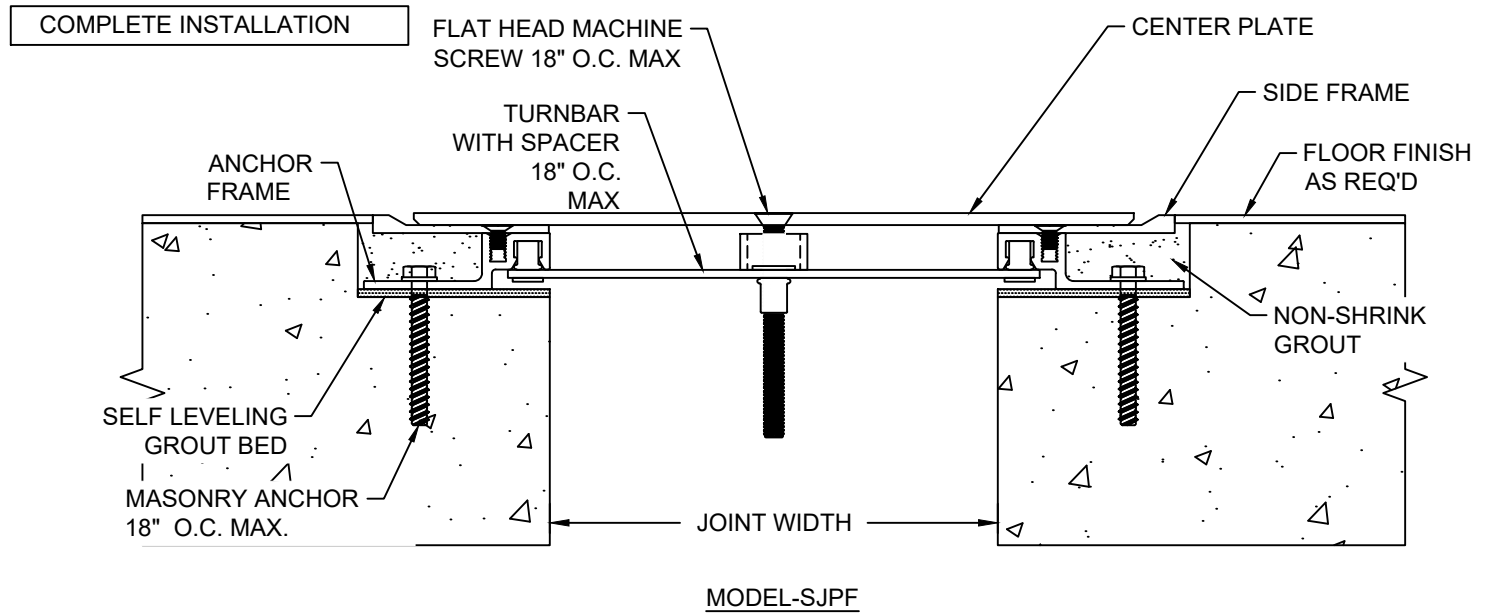

- 6.1) When installation of the Joint Cover has been completed, remove all residue and foreign matter from the area and joint cover.
- 6.2) Clean the CS Joint Cover and adjoining surfaces with proper cleaner.
- 6.3) Protect the Joint Cover until the Architect's final inspection.