

CO-8M and ACO-8M

Product Data

Odd degree metal surface mounted corner guards with standard 3 1/2" legs.

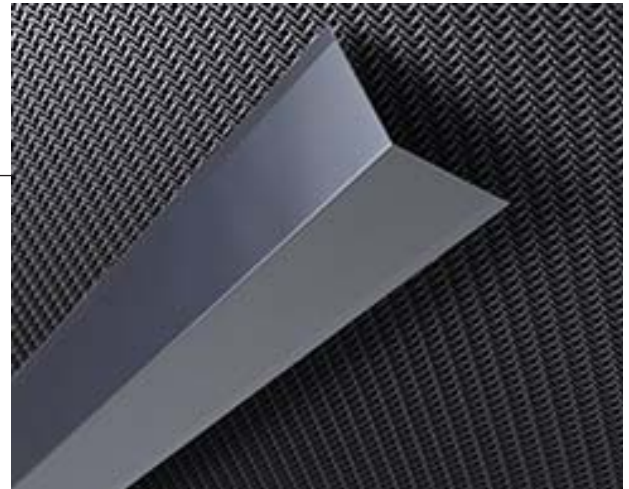

Technical Data:

- 3 1/2" (88.9mm) standard leg; custom leg lengths available
- Construction adhesive standard; optional screws available
- Maximum 12' (3.7m) length
- Specified factory-formed odd degree angle; available between 45-178 degrees

Features:

- Tested in accordance with ASTM E84 Class A/1 fire characteristics
- 5 year product warranty

Options:

- CO-8M - 16 gauge type 304 stainless steel alloy with #4 satin finish; 14, 18 and 20 gauges available; type 316 and 430 alloys available
- ACO-8M - aluminum alloy 5005 H34 with clear anodized finish; .063" (1.6mm)
- Specified custom leg width; minimum 1" (25.4mm) for adhesive or 2" (50.8mm) for screws, maximum 6" (152.4mm)
- Powder coat finishes available

Similar Models:

- CO-8 - stainless steel 90 degree
- ACO-8 - aluminum 90 degree
- SCO-8 - stainless steel end wall
- ASCO-8 - aluminum end wall

Real Metal | Powder Coat

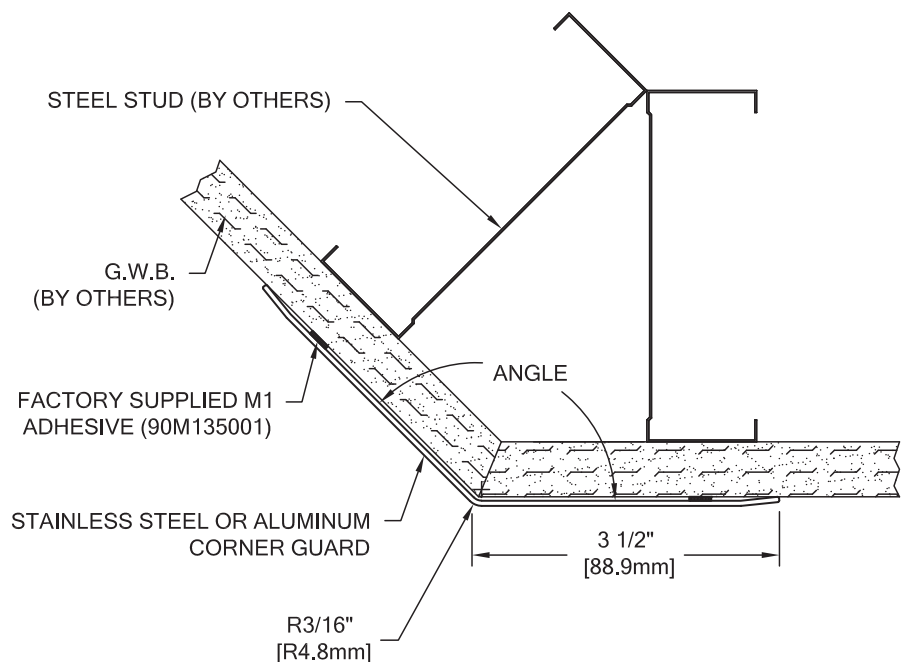

SUGGESTED SPECIFICATIONS SECTION 10 26 00

CS Acrovyn Models CO-8, CO-8M, ACO-8 and ACO-8M

Part 1 - General

1.01 Summary

A. This section includes the following types of wall protection systems:

1. Corner Guards

B. Related sections: The following sections contain requirements related to this section:

1. Handrails, Bumper Guards, Crash Rails, Accent Rails, Wall Covering, Wall Panels, Door Protection; refer to section 10 26 00 "Wall and Door Protection"
2. Blocking in walls for fasteners; refer to section 09 22 00 "Supports for Plaster and Gypsum Board"

1.02 References

A. National codes (IBC, UBC, SBCCI and BOCA and Life Safety)

B. American Society for Testing and Materials (ASTM)

1.03 Submittals

General: Submit the following in accordance with conditions of contract and Division 1 specification section 01 33 00 "Submittal Procedures":

A. Product data and detailed specifications for each system component and installation accessory required, including installation methods for each type of substrate.

B. Shop drawings showing locations, extent and installation details of corner guards. Show methods of attachment to adjoining construction.

C. Samples for verification purposes: Submit the following samples, as proposed for this work, for verification of guard:

1. 12" (304.8mm) long sample of each model specified.

D. Product test reports from a qualified independent testing laboratory showing compliance of each component with requirements indicated.

E. Maintenance data for wall protection system components for inclusion in the operating and maintenance manuals specified in Division 1.

1.04 Quality Assurance

A. Installer qualifications: Engage an installer who has no less than 3 years experience in installation of systems similar in complexity to those required for this project.

B. Manufacturer's qualifications: Not less than 5 years experience in the production of specified products and a record of successful in-service performance.

C. Code compliance: Assemblies should conform to all applicable codes including IBC, UBC, SBCCI, BOCA and Life Safety.

D. Fire performance characteristics: Provide metal components tested in accordance with ASTM E84 for Class A/1 fire characteristics.

E. Single source responsibility: Provide all components of the wall protection system manufactured by the same company to ensure compatibility of color, texture and physical properties.

1.05 Delivery, Storage and Handling

A. Deliver materials to the project site in unopened original factory packaging clearly labeled to show manufacturer.

B. Material must be stored flat.

1.06 Project Conditions

A. Installation areas must be enclosed and weatherproofed before installation commences.

Part 2 - Products

2.01 Manufacturers

A. Interior surface protection products specified herein and included on the submittal drawings shall be manufactured by Construction Specialties, Inc.

2.02 Materials

A. Stainless steel: To be type 304 alloy with #4 satin finish for models CO-8 and CO-8M; minimum strength and durability properties as specified in ASTM A276.

B. Aluminum: To be alloy 5005 H34 with clear anodized finish for models ACO-8 and ACO-8M; minimum strength and durability properties as specified in ASTM B221.

C. All necessary fasteners to be supplied by the manufacturer.

2.03 Corner Guards

A. Stainless steel corner guards to be CS Acrovyn: Surface mounted guards to be 16 gauge stainless steel.

1. Model CO-8 90° stainless steel corner guard with 3/16" (4.8mm) radius and 3 1/2" (88.9mm) standard legs. Bull nose 3/4" (19.1mm) radius optional. Mounted with construction adhesive standard; stainless steel screws optional. Available in variable angles and leg sizes. For odd angle specify model CO-8M. Optional powder coat finish available; select from standard powder coat finishes.

B. Aluminum corner guards to be CS Acrovyn: Surface mounted guards to be .063" (1.6mm) thick.

1. Model ACO-8 90° aluminum corner guard with 3/16" (4.8mm) radius and 3 1/2" (88.9mm) standard legs. Bull nose 3/4" (19.1mm) radius optional. Mounted with construction adhesive standard; stainless steel screws optional. Available in variable angles and leg sizes. For odd angle specify model ACO-8M. Optional powder coat finish available; select from standard powder coat finishes.

2.04 Fabrication

A. General: Fabricate wall protection systems to comply with requirements indicated for design, dimensions, detail, finish and member sizes.

B. Preassemble components in shop as much as possible to minimize field assembly.

2.05 Finishes

A. General: Comply with NAAMM "Metal Finishes Manual" for recommendations relative to applications and designations of finishes.

Part 3 - Execution

3.01 Examination

A. Verification of conditions: Examine areas and conditions under which work is to be performed and identify conditions detrimental to proper or timely completion.

1. Do not proceed until unsatisfactory conditions have been corrected.

3.02 Preparation

A. Surface preparation: Prior to installation, clean substrate to remove dirt, debris and loose particles. Perform additional preparation procedures as required by manufacturer's instructions.

B. Protection: Take all necessary steps to prevent damage to material during installation as required in manufacturer's installation instructions.

3.03 Installation

A. Install the work of this section in strict accordance with the manufacturer's recommendations, using only approved adhesive or mounting hardware and locating all components firmly into position, level and plumb.

3.04 Cleaning

A. General: Immediately upon completion of installation, clean material in accordance with manufacturer's recommended cleaning method.

B. Remove surplus materials, rubbish and debris resulting from installation as work progresses and upon completion of work.

3.05 Protection

A. Protect installed materials to prevent damage by other trades. Use materials that may be easily removed without leaving residue or permanent stains.