

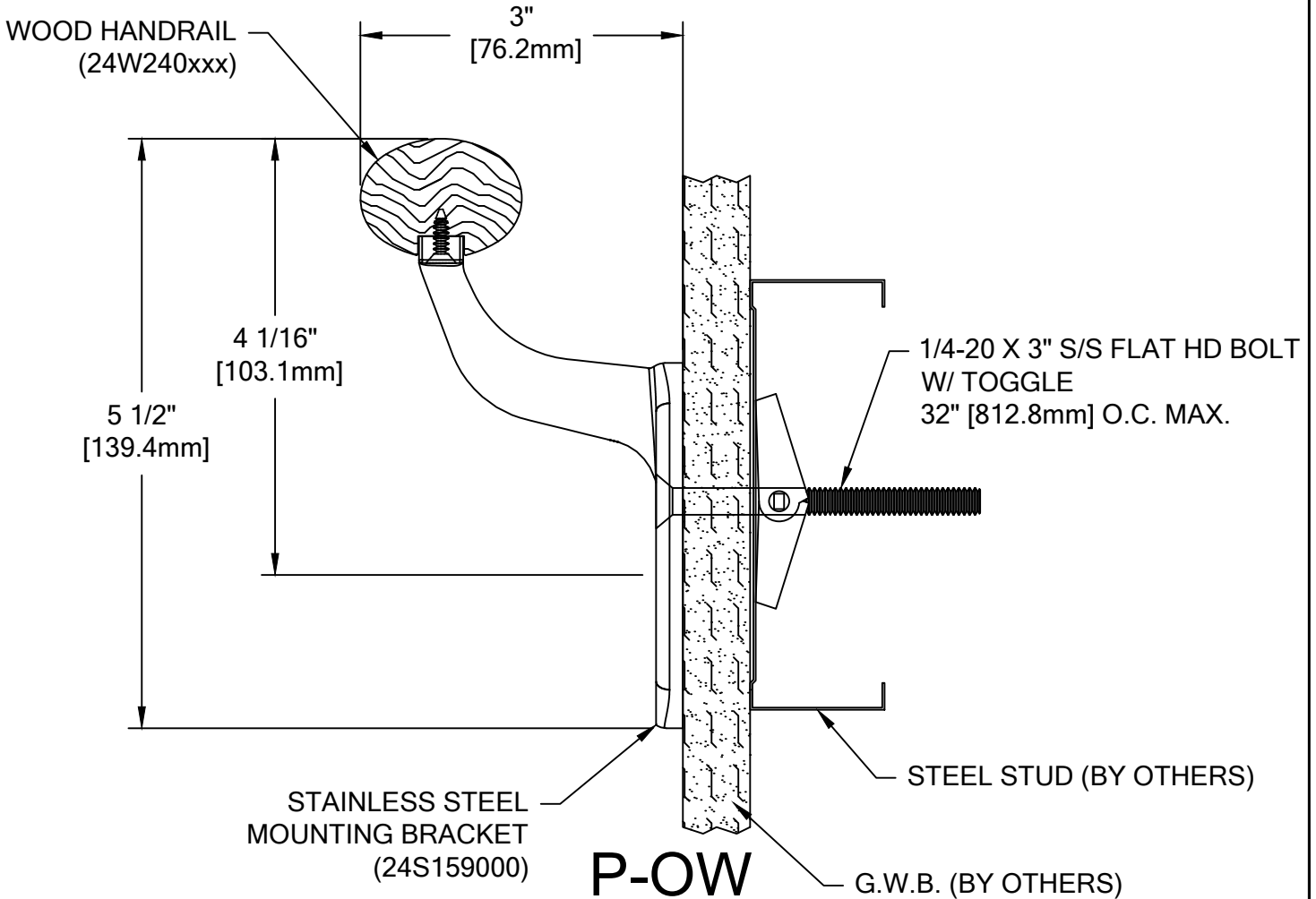

COLOR: _____
 TOP RAIL WOOD SPECIES: _____
 TOP RAIL WOOD FINISH: _____
 *BRACKETS: _____
 COLOR TO BE SELECTED FROM ONE OF C/S STANDARD COLORS.
 *BRACKETS ARE AVAILABLE WITH AN OPTIONAL POWDER COAT FINISH.
 PLEASE ADVISE POWDER COAT FINISH IF REQUIRED.

TOTAL L/F REQ'D	LEFT END CAPS	RIGHT END CAPS	O.S. REQ'D



WALL CONDITION	SPECIFIED FASTENER	DRILL DIAMETERS		C/S PART NUMBER
		WALL	RETAINER	
STEEL STUD/GYPSUM WALL	1/4-20 X 3" S/S FLAT HEAD BOLT WITH TOGGLE	3/4"	N/A	90H184002
CONCRETE/CONC. BLOCK	1/4" X 1 3/4" S/S FLAT HEAD MASONRY ANCHOR	3/16"	N/A	90H390000
WOOD STUD/GYPSUM WALL	#14 X 3" S/S PHILLIPS FLAT HEAD WOOD SCREW	7/32"	N/A	90H538004
20 GA. STEEL STUD/GYPSUM WALL (OSHDP)	1/4-20 X 3" S/S FLAT HEAD BOLT 1/4" TOGGLER WING 3M MOLDABLE FIRE PUTTY	1/2"	N/A	90H063002 90H062004 90M012000
16 GA. MIN STEEL STUD AND 16 GA. MIN STEEL STRAPPING / GYPSUM WALL (CONSTRUCTION REQUIRED) (TEK SCREWS)	#14 X 3" PHILLIPS FLAT HEAD SELF DRILLING S/S TEK SCREW	N/A	N/A	90H230003

 <p>Construction Specialties™ 6696 Route 405 Highway, Muncy PA 17756 (800) 233-8493 • Fax (570) 546-4692 • www.c-sgroup.com</p>	PROJECT:	REVISION:
	JOB NO.:	F&F:
	CUSTOMER:	
	REP:	DATE:
	DRAWN BY:	SHEET NO: