

ECR-60A AND ECR-60S
WITH H-BRACKET

PLEASE READ

PLEASE READ THESE INSTRUCTIONS THOROUGHLY PRIOR TO BEGINNING THE ECR-60 CRASH RAIL INSTALLATION!

THIS INSTRUCTION SHEET IS INTENDED TO PROVIDE A SPECIFIC GUIDE TO FOLLOW FOR THE INSTALLATION OF ECR-60 CRASH RAIL. CONTAINED WITHIN IS THE TECHNICAL INFORMATION AND INSTALLATION TECHNIQUES REQUIRED TO COMPLETE AN EFFICIENT, NEAT AND LONG-LASTING INSTALLATION.

INSPECT ALL MATERIALS FOR DAMAGE OR MISSING PARTS. IF YOU DISCOVER DAMAGED OR MISSING MATERIALS, IN THE USA PLEASE NOTIFY THE FACTORY AT (800) 233-8493, AND IN CANADA (888) 895-8955.

ECR-60 CRASH RAIL MUST BE INSTALLED IN ACCORDANCE WITH THESE INSTRUCTIONS! FAILURE TO FOLLOW THESE INSTRUCTIONS MAY VOID ANY PRODUCT WARRANTIES AND RESULT IN AN UNSUCCESSFUL INSTALLATION. FOR SPECIFIC QUESTIONS REGARDING THE INSTALLATION OF ECR-60 CRASH RAIL PLEASE CALL THE FACTORY AT (800) 233-8493 OR EMAIL IWPTECHSUPPORT@C-SGROUP.COM. IN CANADA CALL (888) 895-8955.

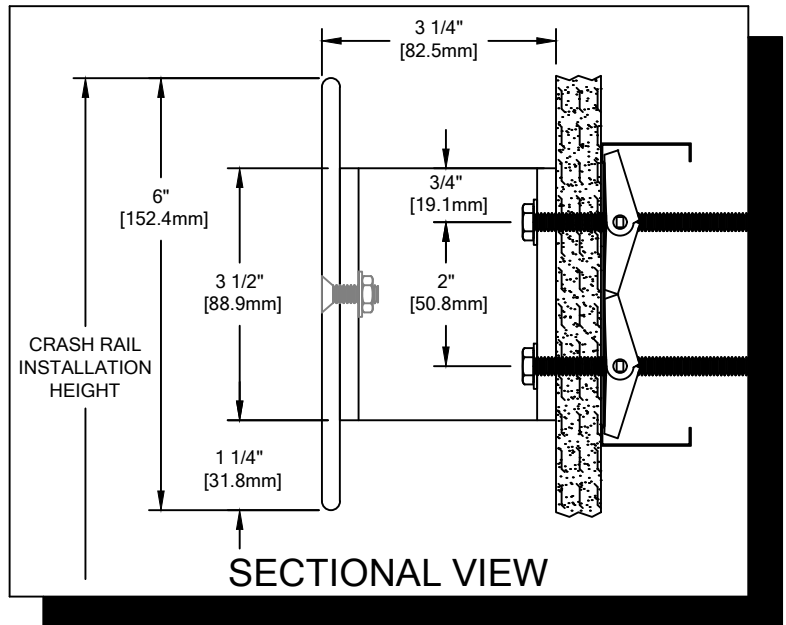

IMPORTANT NOTES

1. THIS MATERIAL HAS BEEN MANUFACTURED TO CUSTOMER SPECIFIED DIMENSIONS AND CAN NOT BE CUT OR MODIFIED ON SITE. TO DO SO COULD VOID THE WARRANTY.
2. RADIAL MATERIAL MAY BE SUPPLIED FACTORY FORMED OR IN STRAIGHT LENGTHS FOR FIELD FORMING. CONSULT FACTORY FOR OPTIONS.
3. TANGENT POINTS ON FACTORY FORMED RADIAL MATERIAL WILL BE MARKED APPROXIMATELY AND SHOULD BE CUT TO SUIT FIELD CONDITIONS.
4. ALL DIMENSIONS ARE TYPICAL.
5. FOR DRYWALL/PLASTER WALL CONSTRUCTION, IT IS RECOMMENDED FOR FASTENERS TO BE ENGAGED INTO METAL/WOOD STUDS TO MAINTAIN MAXIMUM PULLOUT STRENGTH. IF DURING INSTALLATION YOU ENCOUNTER SPECIAL WALL CONDITIONS THAT DO NOT ALLOW FOR DIRECT ATTACHMENT TO THE STUDS PLEASE CONSULT THE LOCAL AUTHORITY HAVING JURISDICTION.
6. MATERIAL MUST REACH 65°F MIN. TO 75°F MAX. 24 HOURS PRIOR TO INSTALLATION. THIS IS ESSENTIAL TO MINIMIZE EXPANSION AND CONTRACTION OF MATERIAL.
7. MAY REQUIRE USE OF FIRE PUTTY WHEN INSTALLED ON FIRE WALL WITH TOGGLE BOLTS. REFERENCE INSTRUCTIONS 24FIREPUTTY FOR FIRE PUTTY INSTALLATION.
8. THIS CRASH RAIL REQUIRES A MINIMUM OF 2 MOUNTING BRACKETS PER UNIT. MINIMUM END RETURN TO END RETURN RUN IS 13" [330.2mm]
9. FOR MORE INFORMATION ON ECR-60 CRASH RAIL SEE OUR WEBSITE AT www.c-sgroup.com.

ECR-60A AND ECR-60S

COMPONENTS & WALL FASTENERS



ECR-60A ALUMINUM CRASH RAIL
(24A297000)

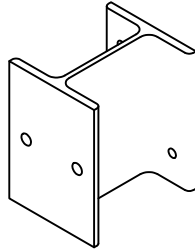

ALUMINUM BRACKET
(24F195003)

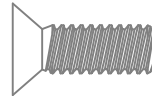

FASTENER #1
1/4-20 x 3/4" PHILLIPS
FLAT HEAD MS SS
(90H019002)



FASTENER #2
1/4" LOCK WASHER
(90H009003)



ECR-60S STAINLESS STEEL CRASH RAIL
(24S153000)



FASTENER #3
1/4-20 HEX NUT
(90H001001)

WALL CONDITION	SPECIFIED FASTENER	DRILL DIAMETERS		CS PART NUMBER
		WALL	RETAINER	
STEEL STUD/GYPSUM WALL	1/4-20 X 3" HEX HEAD BOLT 1/4-20 X 2" TOGGLER 1/4" LOCK WASHER	3/4"	N/A	90H281004 90H019004 90H009003
CONCRETE/CONC. BLOCK	1/4-20 X 1 1/12" HEX HEAD BOLT 1/4" LOCK WASHER 1/4-20 X 1 1/4" 4-WAY LEAD SHIELD	1/2"	N/A	90H863002 90H009003 90H020004
WOOD STUD/GYPSUM WALL	1/4" X 3" HEX HEAD LAG SCREW 1/4" LOCK WASHER	3/16"	N/A	90H967002 90H009003

ECR-60A AND ECR-60S

LAYOUT VIEW

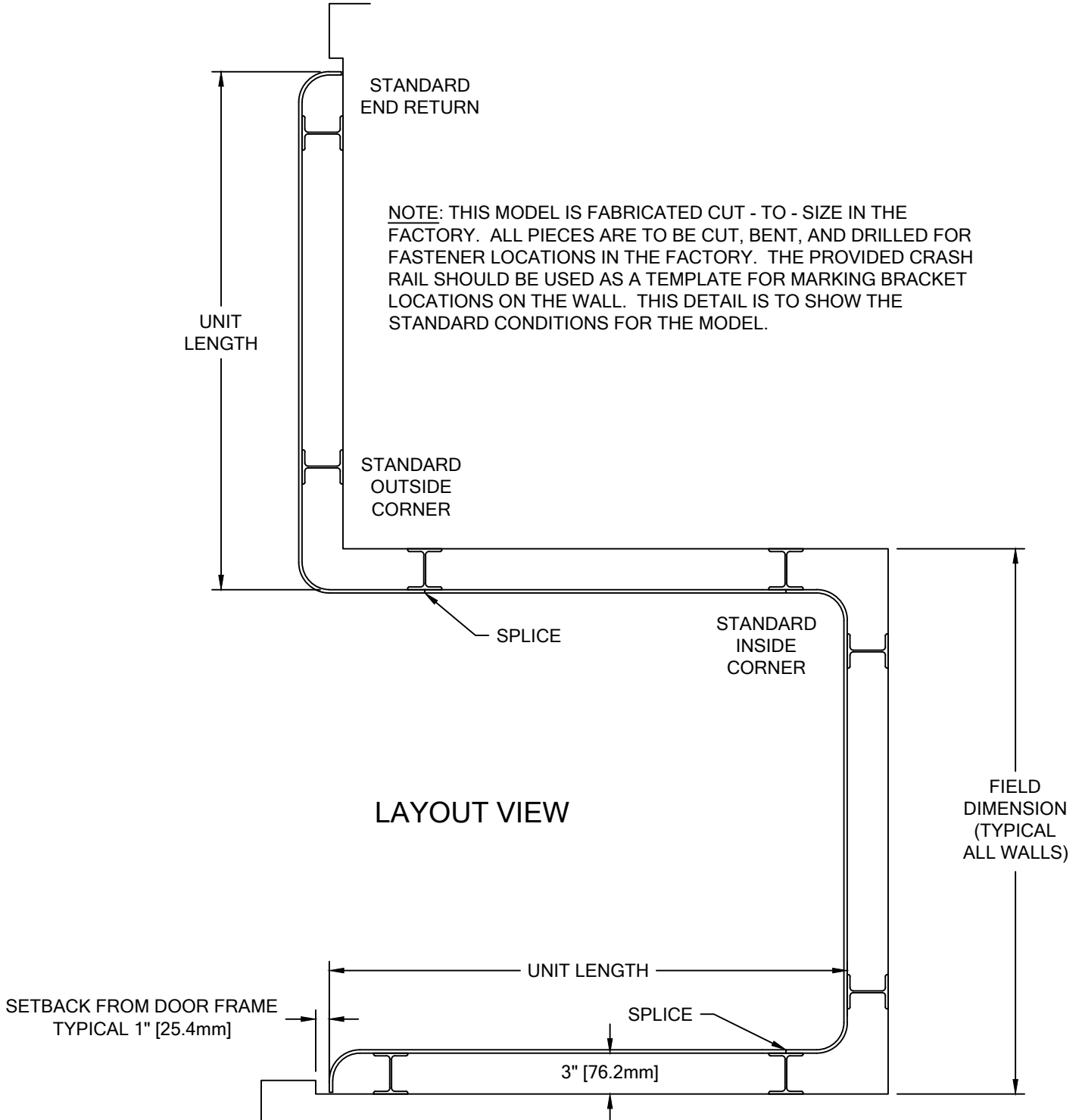

ECR-60A AND ECR-60S

TYPICAL ASSEMBLY

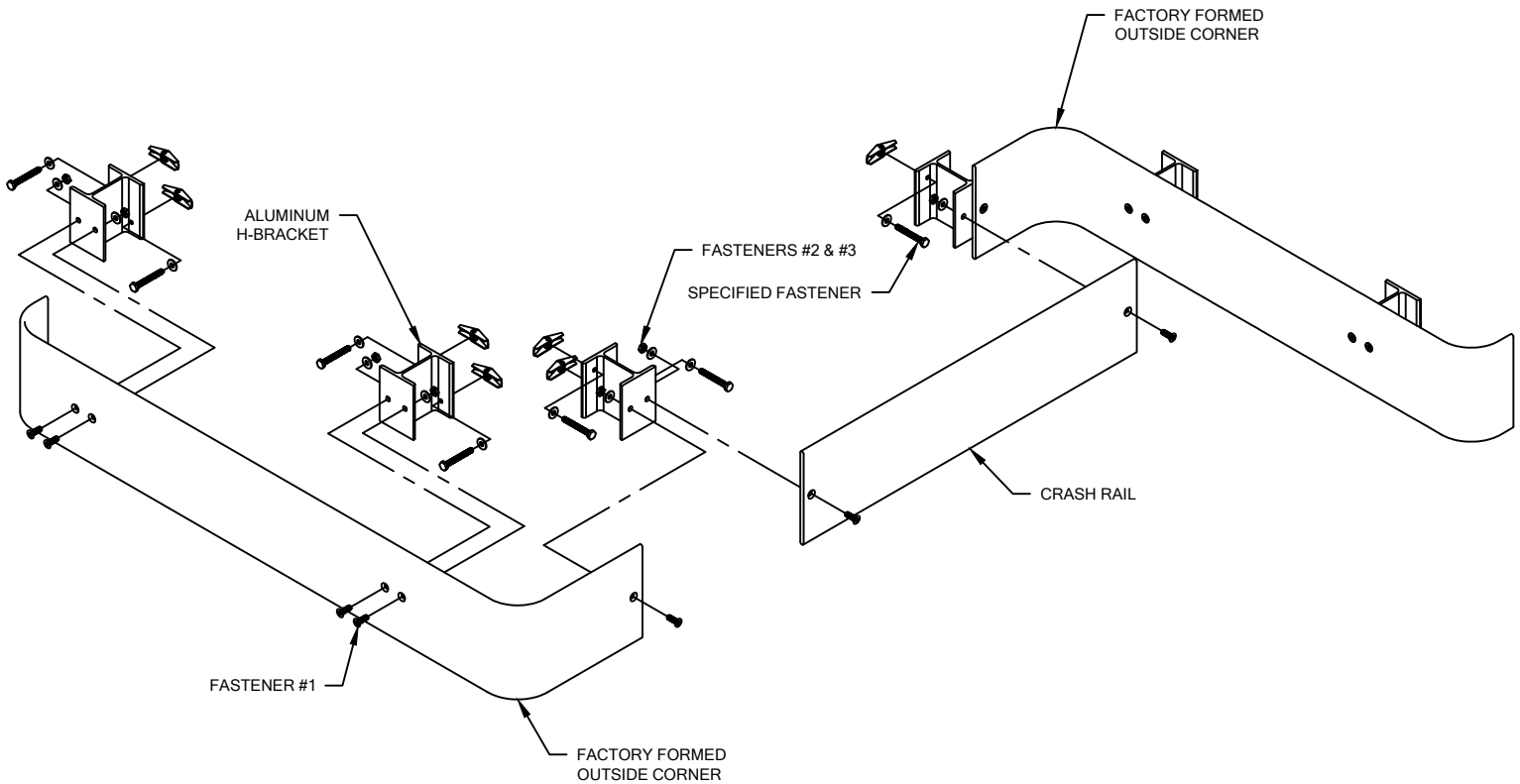

NOTE: INSTALLATION OF LINEAL OR RADIAL ECR-60 CRASH RAIL SHOULD BE DONE IN ACCORDANCE WITH THE FOLLOWING INSTRUCTIONS.

1. DISTRIBUTE MATERIAL. MATCH THE NUMBER ON THE BACK OF THE RAIL TO THE MARK NUMBER ON THE DRAWING. SOME LARGE RUNS REQUIRE MORE THAN ONE PIECE OF CRASH RAIL. THESE ARE NOTED WITH A MARK NUMBER AND A LETTER, I.E. 2001A 2001B.
2. ESTABLISH CRASH RAIL HEIGHT ABOVE THE FINISHED FLOOR. DEDUCT 1/4" [6.35mm] TO LOCATE TOP EDGE OF BRACKET. SNAP A CHALK LINE AT THIS HEIGHT.
3. ATTACH BRACKETS TO RAIL WITH SPECIFIED FASTENERS.
4. DRILL CLEARANCE HOLES IN WALL SURFACE FOR MOUNTING HARDWARE, USING THE CRASH RAIL WITH ATTACHED BRACKETS AS A TEMPLATE. REFERENCE CHART ON PAGE 2 FOR CORRECT DRILL DIAMETERS.
5. ONCE BRACKET LOCATIONS ARE ESTABLISHED ON THE WALL, REMOVE BRACKETS FROM THE RAIL.
6. LOOSELY ATTACH BRACKETS TO WALL WITH SPECIFIED FASTENERS.
7. INSTALL EACH SECTION OF CRASH RAIL, IN SUCCESSION, USING APPROPRIATE HARDWARE. USE A LEVEL TO INSURE CRASH RAIL IS LEVEL.

NOTE: WHEN FIELD FORMING RADIUS CRASH RAIL, BE SURE TO APPLY NEEDED PRESSURE FROM BRACKET TO BRACKET.

8. TIGHTEN ALL FASTENERS AND REMOVE PROTECTIVE COATING FROM RAIL TO COMPLETE INSTALLATION.

1/31/18