

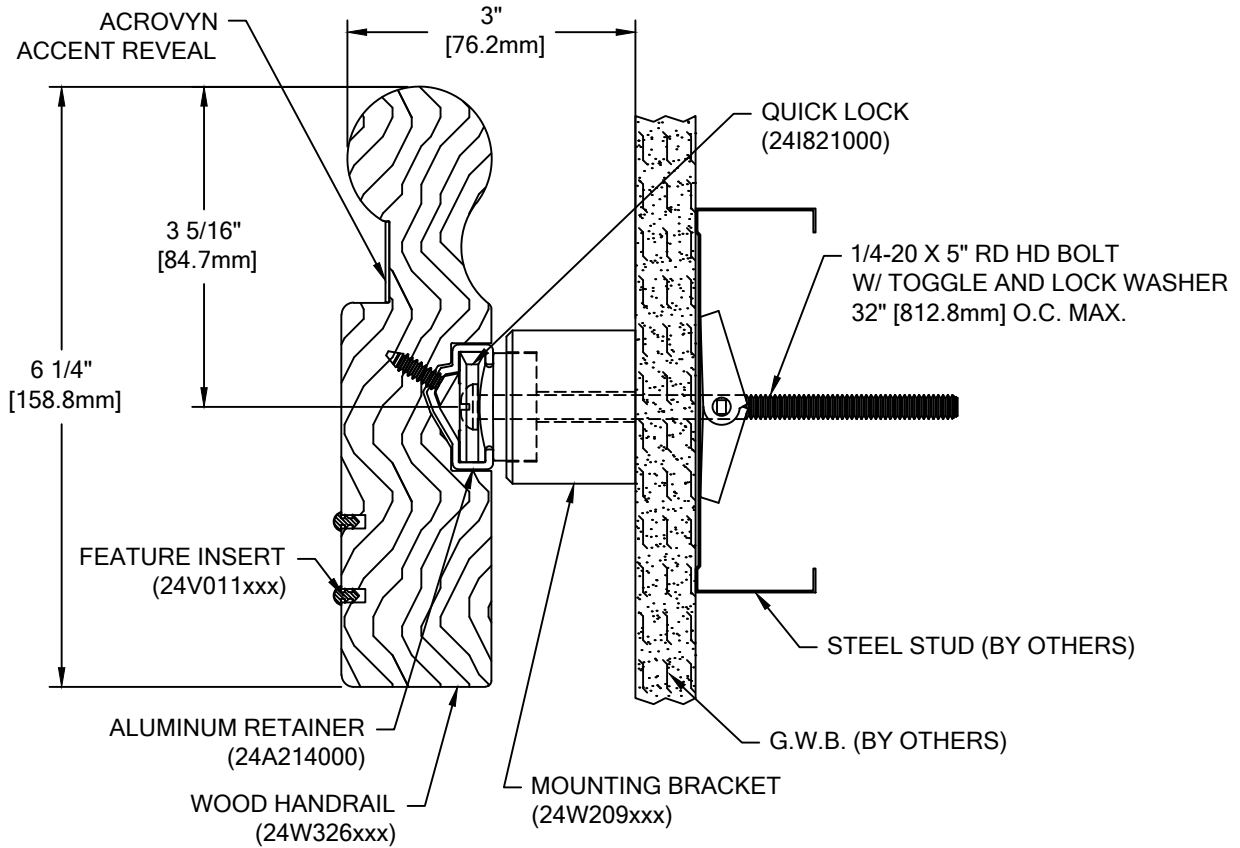

COLOR: _____
 HANDRAIL WOOD SPECIES: _____
 HANDRAIL WOOD FINISH: _____
 ACROVYN ACCENT REVEAL: _____
 COLOR TO BE SELECTED FROM ONE OF C/S STANDARD COLORS.
 FEATURE INSERT COLOR: _____
 REFER TO C/S CATALOG FOR FEATURE INSERT COLORS.

TOTAL L/F REQ'D	LEFT END CAPS	RIGHT END CAPS	O.S.C. REQ'D



HRW-10CQV

WALL CONDITION	SPECIFIED FASTENER	DRILL DIAMETERS		C/S PART NUMBER
		WALL	RETAINER	
STEEL STUD/GYPSUM WALL	1/4-20 X 5\"/>			
CONCRETE/CONCRETE BLOCK	#14 X 5\"/>			
WOOD STUD/GYPSUM WALL	#14 X 5\"/>			

 <p>Construction Specialties™ 6696 Route 405 Highway, Muncy PA 17756 (800) 233-8493 • Fax (570) 546-4692 • www.c-sgroup.com</p>	PROJECT:	REVISION:
	JOB NO.:	F&F:
	CUSTOMER:	
	REP:	DATE:
	DRAWN BY:	SHEET NO: