

MODEL LSRR & LSRW 800-2400 ROOF COVER INSTALLATION INSTRUCTIONS

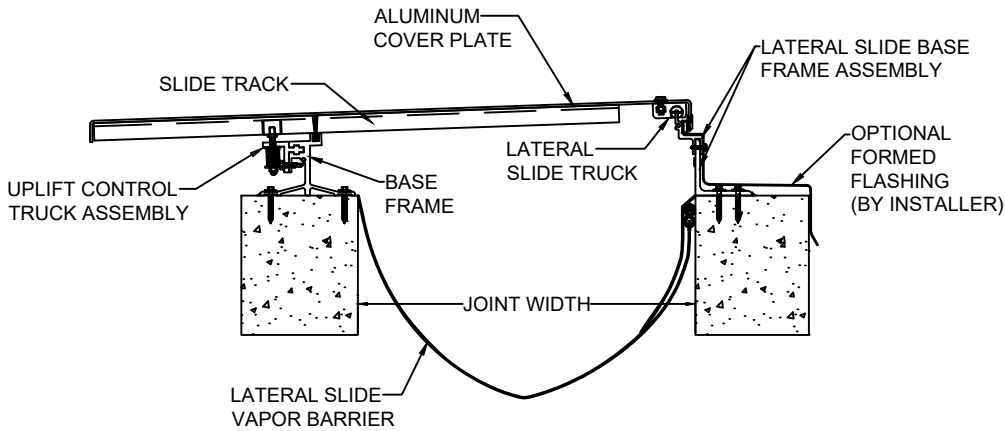

LSRR

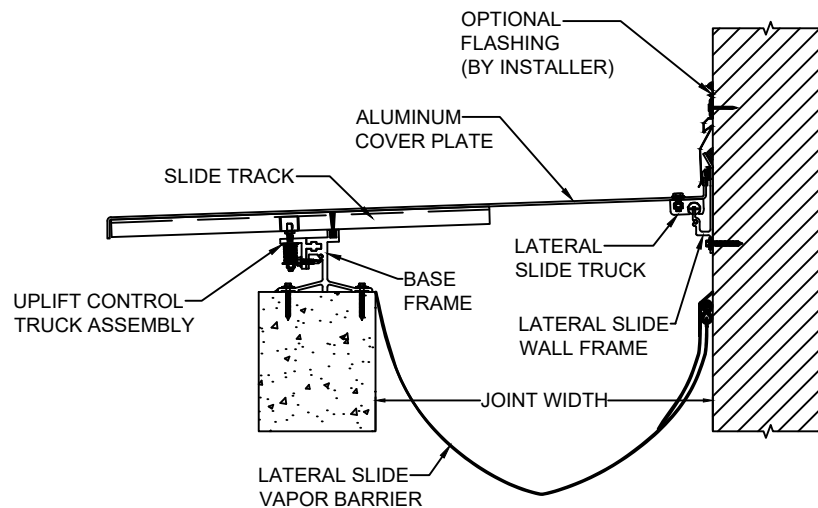

LSRW

IMPORTANT INFORMATION

Prior to the commencement of Installation, all materials **MUST** be inspected for Damage. Any damage must be reported to CONSTRUCTION SPECIALTIES, INC., as soon as possible, so that replacement materials may be furnished without delay.

All work must be completed as per Architect's Approved "Shop Drawings", and in accordance with these Installation Instructions. When installation is complete, all materials must be protected from damage until the Architect's FINAL INSPECTION.

IMPORTANT:

READ THROUGH ALL INSTRUCTIONS PRIOR TO STARTING INSTALLATION

All materials should be arranged in the order that they are to be installed. All hardware required for each portion of the work should be placed with the appropriate materials.

Please review all Approved Shop Drawings and this Document to familiarize yourself with all the details and components of this assembly.

8/23/24



Construction Specialties[®]
www.c-sgroup.com

6696 Route 405 Highway, Muncy, PA 17756
Phone: (800) 233-8493 / Fax: (570) 546-8022

This document is the property of Construction Specialties, Inc. and contains PROPRIETARY INFORMATION that is not to be disclosed to third parties and is not to be used without approval in writing from Construction Specialties, Inc.

© Copyright 2016 Construction Specialties, Inc.

Notes

Before beginning installation, review the architectural drawings and approved Construction Specialties Inc. shop drawings to familiarize yourself with the joint cover models and locations.

Check all of the joint cover components to confirm that the correct joint cover model and size have been received. Also, check for materials that may have been damaged during shipping. Report all incorrect and/or damaged components to CS at 800-233-8493.

Read through all the steps of these instructions prior to beginning work.

Check the joint to make sure that it is clear of any materials that will impede the installation of the roof cover. Make sure that the area around the joint is clean and accessible.

Lateral Slide Roof to Wall and Roof to Roof slide trucks are to align and must be kept to the same side of the joint.

STEP 1

LATERAL SLIDE VAPOR BARRIER INSTALLATION

Step 1:

1.1) Reference and review the installation instructions for the installation of the Lateral Slide Vapor Barrier instruction of 12GA.

NOTE: However, if the Vapor Barrier is installed without the Vapor Barrier Frames installed in the joint space, run the Vapor Barrier under Lateral Slide Base Frame Assembly (roof to roof) or the Lateral Slide Wall Frame (roof to wall) and the Base Frame. Install attaching both the frames and Vapor Barrier using the supplied CS fasteners. Apply a continuous bead of Caulk running down the length of the frames.

STEP 2

MOUNTING ROOF FRAME INSTALLATION

Step 2:

- 2.1) Begin installation of the Lateral Slide Base Frame Assembly by aligning the Frame Assembly flush and parallel with the edge of the joint.
- 2.2) Using the Frame as a template, drill the hole locations of the C/S supplied fasteners. (Follow the drilling instructions provided for the C/S supplied fastener per manufacturer's guidelines.)



Step 2:

- 2.3) Remove the Lateral Slide Base Frame Assembly and cleanout the drilled holes.
- 2.4) Reposition the Lateral Slide Base Frame Assembly aligning the frame holes with the drilled fastener holes. Anchor the Frame Assembly with the CS supplied fasteners.
- 2.5) For additional lengths of the Lateral Slide Frame Assembly place grooved end of alignment pin in the alignment slot approximately 1/2 of it's length. Align additional lengths of Frame to the installed alignment pins of the previous Lateral Slide Frame Assembly for proper alignment.

STEP 2 CON'T

MOUNTING ROOF TO WALL FRAME INSTALLATION

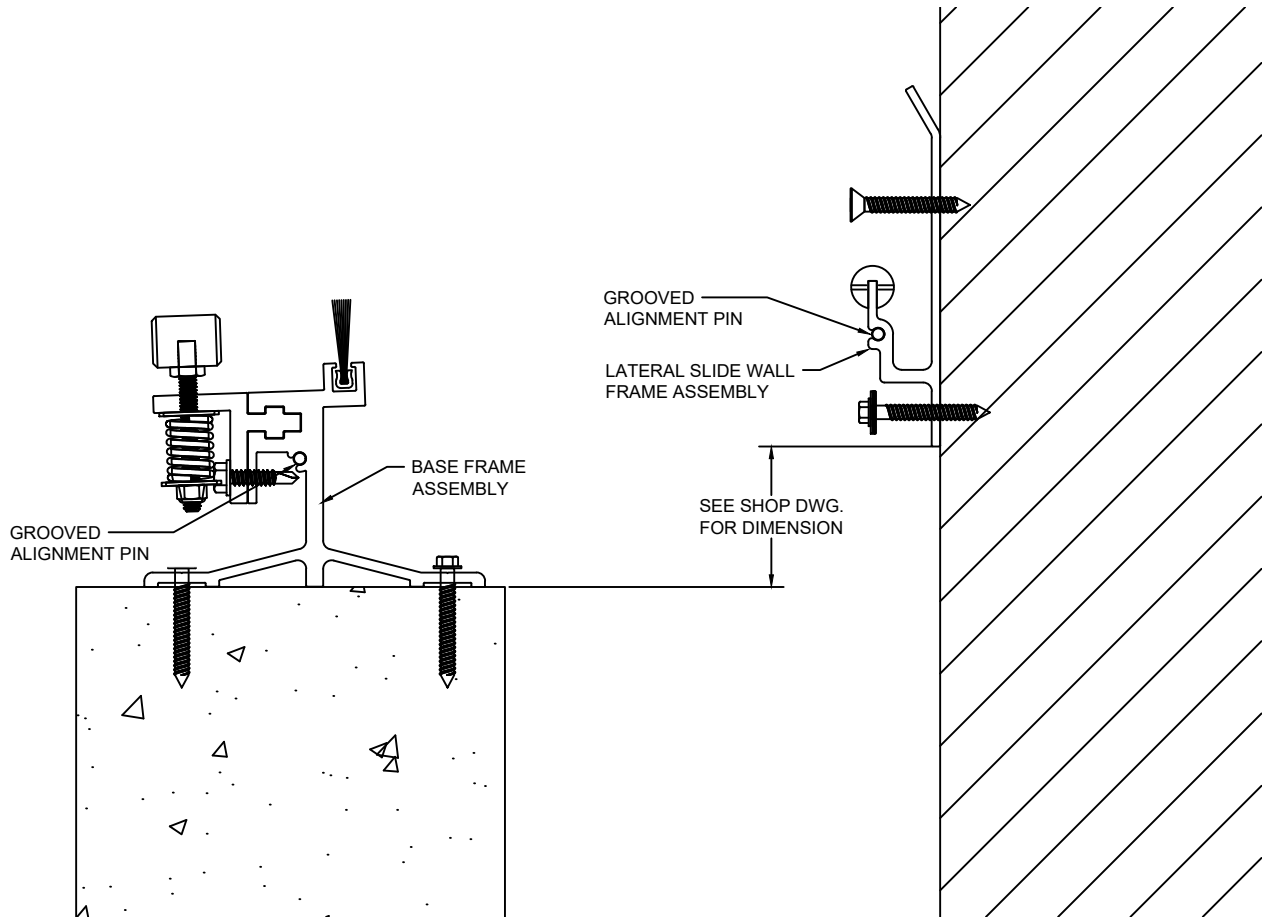

Step 2a:

- 2a.1) Along the face of the roof wall establish a level chalk line above and parallel to the top of the concrete curb to the bottom edge of the Lateral Slide Wall Frame Assembly. See shop drawing details for dimension from curb to bottom of Frame Assembly.
- 2a.2) Position a 10' length of Lateral Slide Wall Frame along chalk line. Using the Frame as a template mark and drill the hole locations of the C/S supplied fasteners per manufacturer's guidelines.
- 2a.3) Reposition the Lateral Slide Wall Frame assembly aligning the frame holes with the drilled fastener holes. Anchor with the supplied CS fasteners.
- 2a.4) For additional lengths of the Lateral Slide Wall Frame place grooved end of alignment pin in the alignment slot approximately 1/2 of it's length. Align additional lengths of Frame to the installed alignment pins of the previous Lateral Slide Wall Frame for proper alignment.

STEP 3

BASE FRAME INSTALLATION

Step 3:

- 3.1) Begin installation of the Base Frame Assembly by setting the Base Frame Assembly 1/2" back and parallel with the joint edge.
- 3.2) Using the Base Frame Assembly as a template, drill the hole locations of the C/S supplied fasteners on both sides of the frame. (Follow the drilling instructions provided for the C/S supplied fastener per manufacturer's guidelines.)

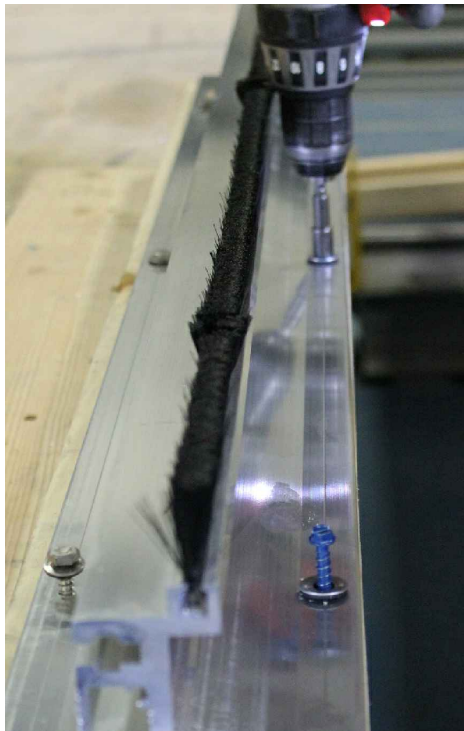

Step 3:

- 3.3) Remove the Base Frame Assembly and cleanout the drilled holes.
- 3.4) Reposition the Base Frame Assembly aligning the frame holes with the drilled fastener holes. Anchor the Base Frame Assembly with the CS supplied fasteners.
- 3.5) For additional lengths of the Base Frame Assembly place grooved end of alignment pin in the alignment slot approximately 1/2 of its length. Align additional lengths of Frame to the installed alignment pins of the previous Base Frame Assembly for proper alignment.

STEP 4

UPLIFT CONTROL TRUCK INSTALLATION

Step 4:

- 4.1) Place the Cover Plate, with the Slide Track already attached, on its back.
- 4.2) Slide one Uplift Control Truck Assembly into each Slide Track channel. Slide the Assembly to the opposite end of the Slide Track channel.
- 4.3) Flip the Cover Plate over with the protective film facing up.

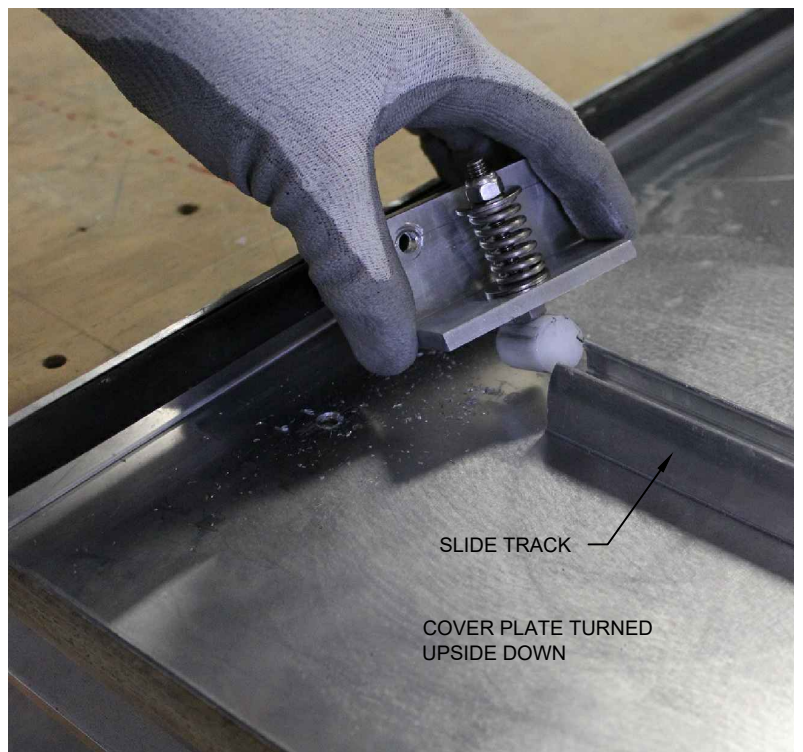

STEP 4 CON'T.

UPLIFT CONTROL TRUCK INSTALLATION

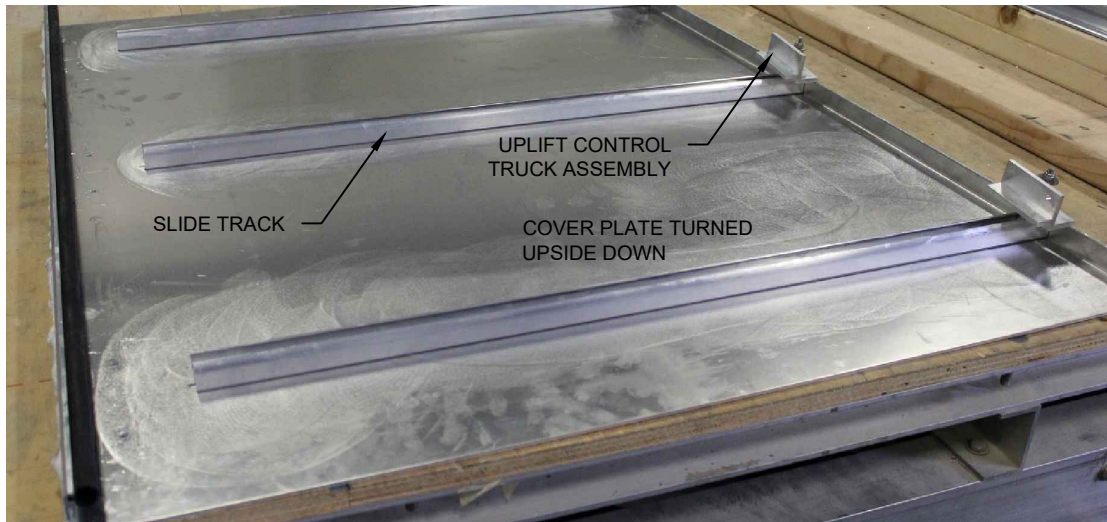

Step 4: Con't.

4.4) With the Uplift Control Truck Assemblies at the opposite end of the Slide Track Channel flip the Cover Plate over with the protective film facing up.

STEP 5

ROTATIONAL FRAME INSTALLATION

Step 5:

5.1) Begin installation of the Rotational Frame by sliding the Frame onto the Lateral Slide Base Frame Assembly. **Note: The Rotational Frame is one continuous 10' length.

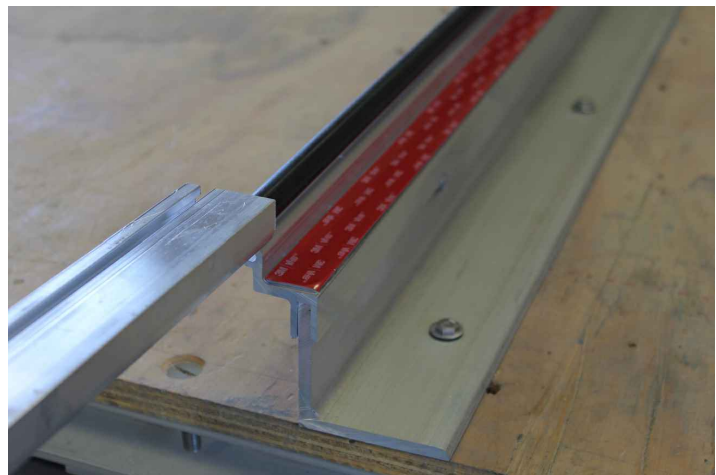
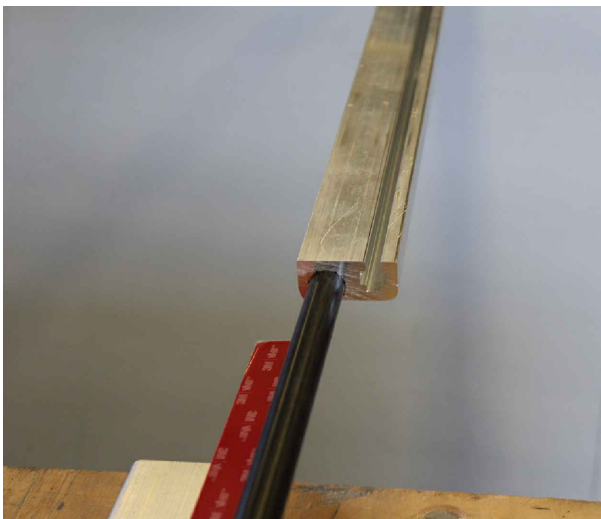

Note: For Roof to Wall installation:

5a.1) Begin installation of the Rotational Frame by sliding the Frame onto the Lateral Slide Wall Frame Assembly. **Note: The Rotational Frame is one continuous 10' length.

STEP 5 CON'T.

ROTATIONAL FRAME INSTALLATION

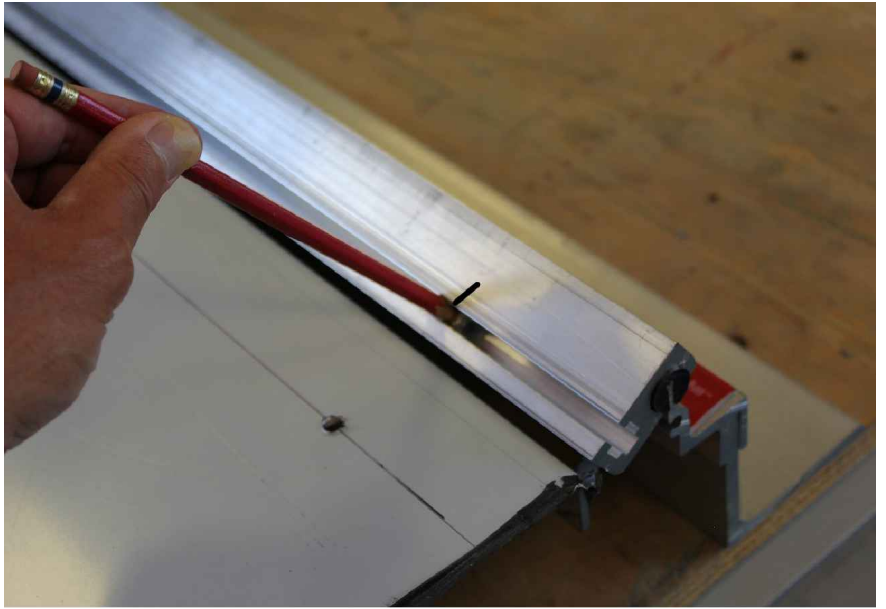

Step 5: Con't.

5.2) Using the cover plate drilled holes as a guide, mark each centerline locations on the Rotational Frame.

5.3) Position Jamb Nuts at each centerline location marked on the Rotational Frame.



NOTE: If your roof cover is with the Optional Formed Flashing by the installer, the Flashing piece needs to be installed over the Lateral Slide Base Frame Assembly at this point.

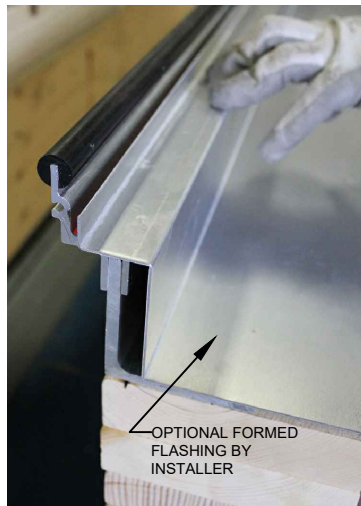

Optional Formed Flashing Roof to Roof Option:

- 1) To adhere the Optional Formed Flashing piece double faced tape is applied to the frame assembly.
- 2) Peel the paper backing from the tape and position the Optional Formed Flashing piece to the Frame Assembly. Pressing firmly to adhere the Optional Flashing to the Frame Assembly.

STEP 6

COVER PLATE INSTALLATION

- 6.1) Lift the Cover Plate, with the protective film showing, into position aligning the Cover Plate edge with the end of the Rotational Frame. Align the holes in the Cover Plate with the jamb nuts in the Rotational Frame.

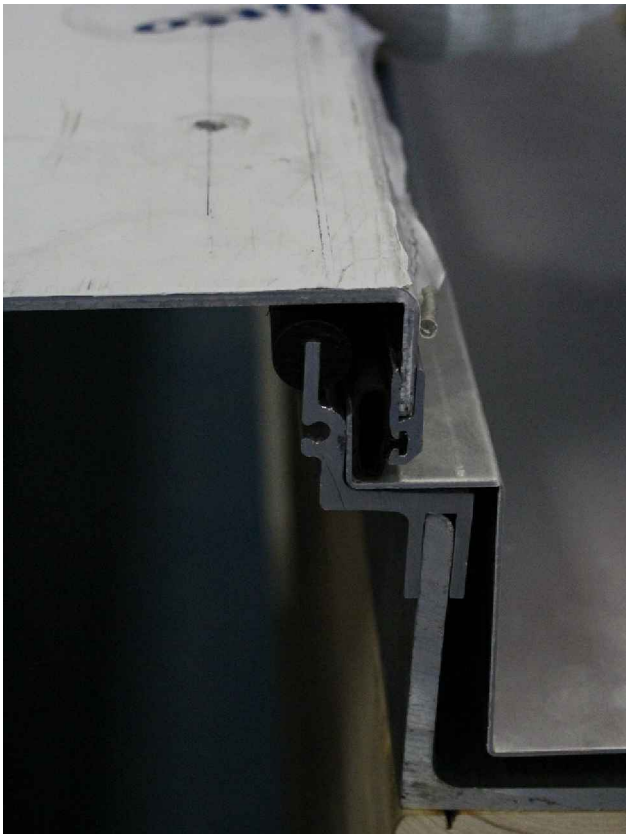
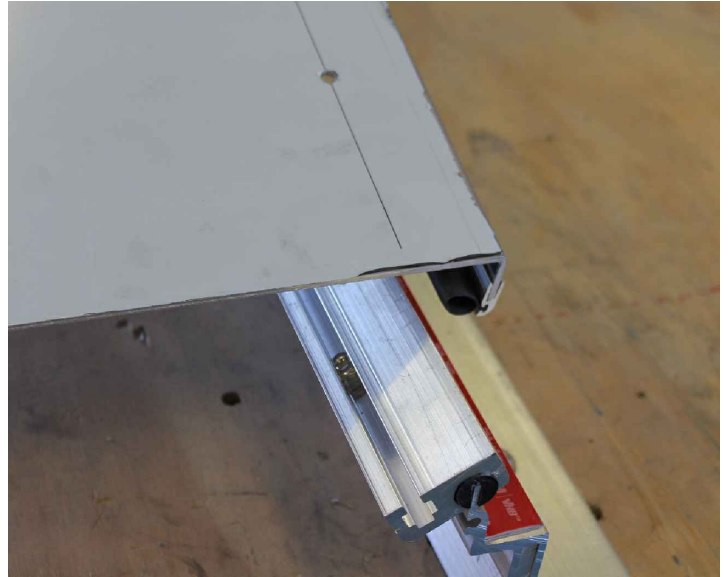

- 6.2) Install CS supplied hex head machine screws and sealing washers at each drilled hole of the Cover Plate. Finger tighten each bolt in progression along Cover Plate length. Go back and tighten each per Manufacture's guidelines.



STEP 7

MOUNTING FRAME /ROOF WELDMENT INSTALLATION



Step 7:

- 7.1) Slide the Uplift Control Assembly into the Base Frame slot. Fasten each assembly using the supplied CS fasteners.

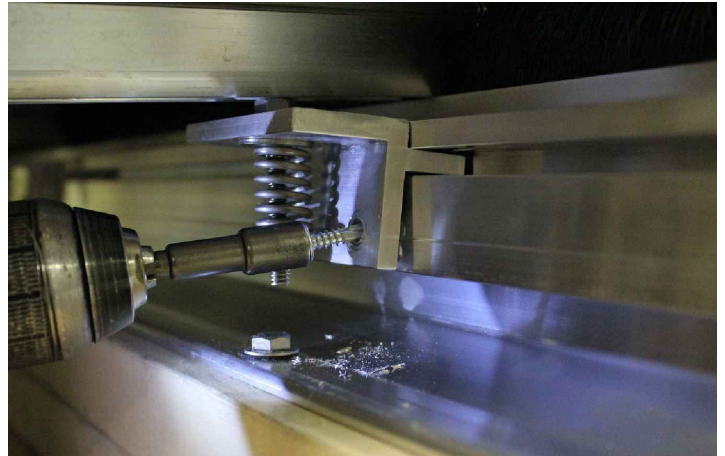
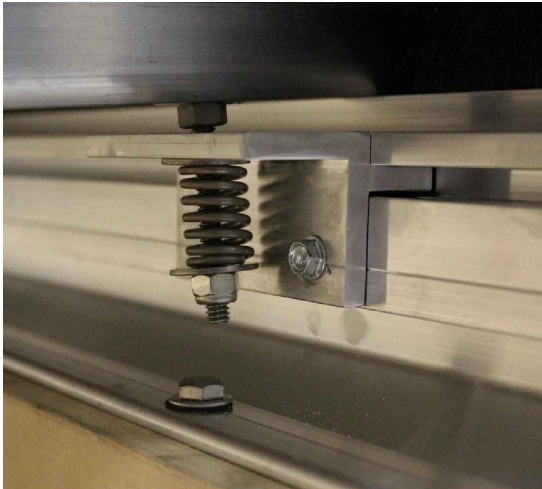

- 7.2) Repeat these installation instructions for any additional lengths of LSRR and LSRW.
- 7.3) Remove the protective plastic film from all Cover Plates.

NOTE: The LSRR-LSRW are supplied in 10' lengths. Establish the required lengths needed for each run of cover and cut the pieces to length if needed. If additional length or lengths of Cover Plate are required for the run, prepare and install the Cover Plates as instructed in Steps 1 through 7. Maintain a 1/16" minimum splice joint between lengths.

STEP 8

INSTALL SPLICE PLATES

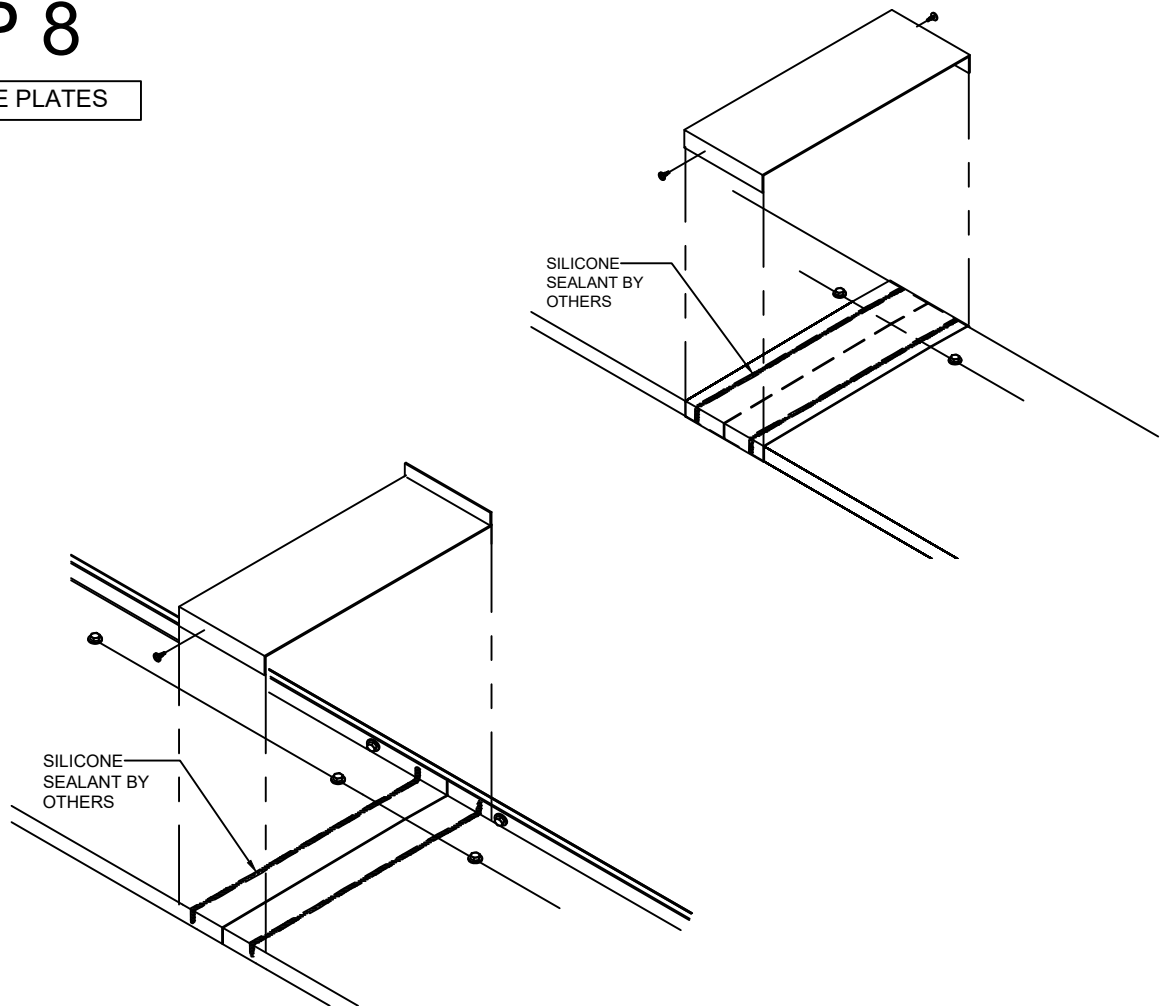

Step 8:

Note: Install factory fabricated Splice Covers at the splice joints between lengths of Cover Plates and Transitions. It is recommended that a RTV silicone sealant to be used by others. Install the End Caps and Transition Covers where required. Transition Covers are with sealant only and cannot overhang the vertical sides of the Cover Plate due to differential movement that will occur at this location.

- 8.1) Place a bead of sealant (by others) 1 1/2" in from the splice edge across the full width of the Cover Plate, on each side of the splice joint.
- 8.2) Center the Splice Cover over the joint and seat the Splice Cover into the sealant, and fitting over the Cover Plate.
- 8.3) Attach the Splice Cover to the Cover Plate by inserting one self-drilling sheet metal screw into each vertical sides of the Cover Plates due to differential movement that will occur at this location.

STEP 9

Roof To Wall Optional Flashing

Step 9:

Note: Optional Formed Flashing Roof to Wall Option installed after the cover plate installation is complete.

- 9.1) Optional Formed Flashing and Reglet piece fastened above and over the Lateral Slide Wall Frame and Cover Plate.

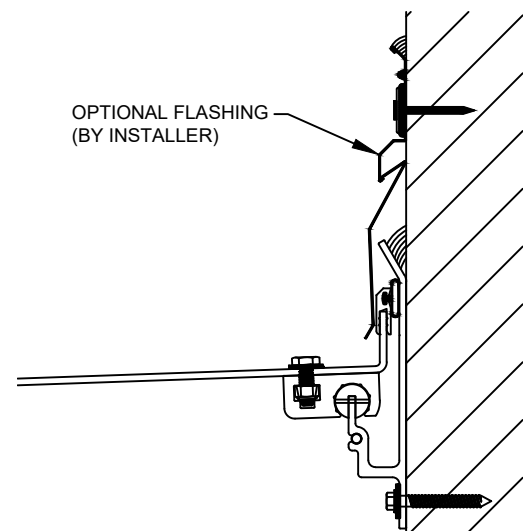

STEP 8

COMPLETE INSTALLATION

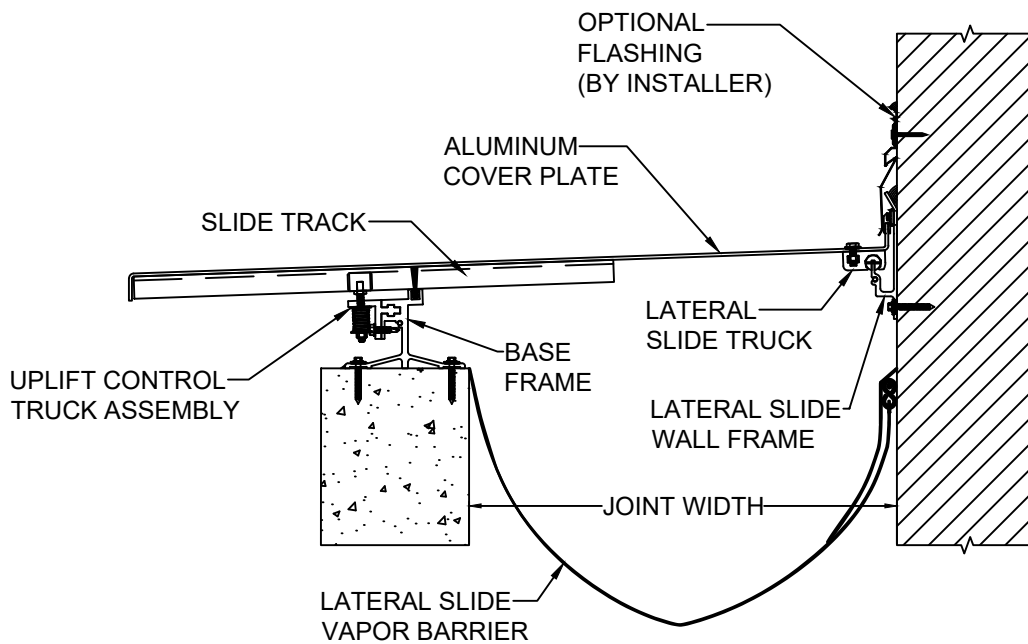
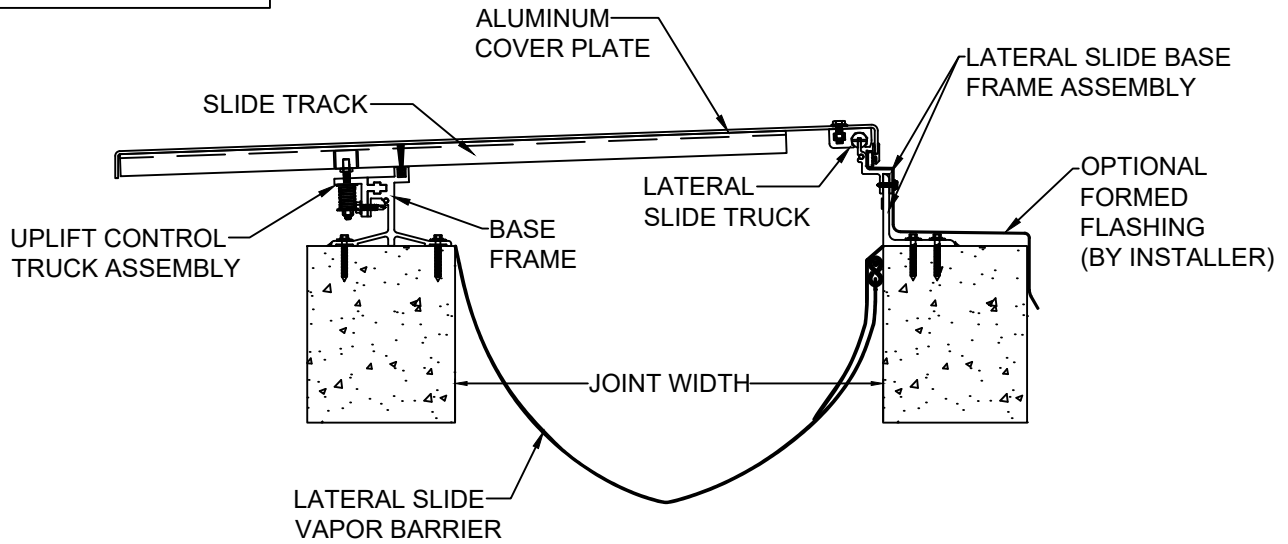

Step 8:

- 8.1) To complete the installation of the LSRW, apply sealant (by others) along the top edge of all LSRW Lateral Slide Wall Frames and Splice Plate Covers.
- 8.2) Installation of the C/S Roof Expansion Joint Cover has been completed, remove all residue and foreign matter from the area and joint cover.
- 8.3) Clean the C/S Joint Cover and adjoining surfaces with proper cleaner.
- 8.4) Protect the Joint Cover until the Architect's final inspection.