

**NOTES:**

1. THIS MODEL IS FABRICATED CUT-TO-SIZE, THEREFORE FIELD VERIFIED DIMENSIONS ARE REQUIRED.
2. ALL RAIL TO BE SUPPLIED PREFABRICATED TO REQUIRED LENGTH. ALL CORNERS AND END CAPS TO BE FACTORY FORMED TO SUITE FIELD DIMENSIONS.
3. ALL UNITS TO BE PRE-DRILLED FOR ATTACHMENT. HOLE SPACING TO BE DETERMINED BY UNIT LENGTH, SPACING NOT TO EXCEED 32" ON CENTER.
4. ALL MOUNTING HARDWARE TO BE SUPPLIED FOR FIELD ASSEMBLY AND INSTALLATION.

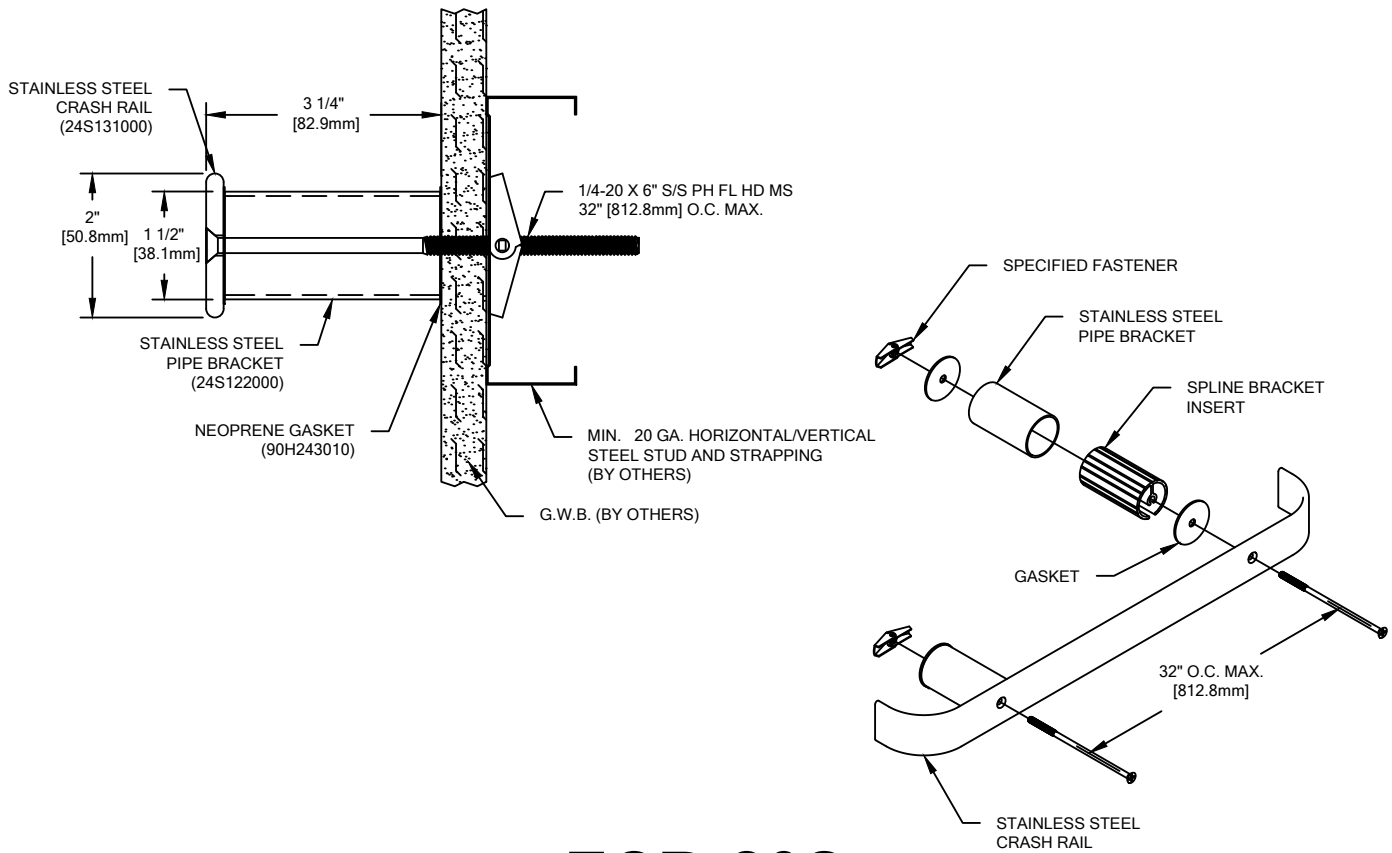

# ECR-20S

TYPICAL ASSEMBLY

WALL CONDITION	SPECIFIED FASTENER	DRILL DIAMETERS		CS PART NUMBER
		WALL	RETAINER	
STEEL STUD/GYPSUM WALL	1/4-20 X 6" S/S PHILLIPS FLAT HEAD MS 1/4-20 TOGGLER	3/4"	N/A	90H307002 90H019004
CONCRETE/CONC. BLOCK	1/4-20 X 5" S/S PHILLIPS FLAT HEAD MS 1/4-20 X 1 1/4" 4-WAY LEAD SHIELD	1/2"	N/A	90H308002 90H020004
WOOD STUD/GYPSUM WALL	#14 X 6" PHILLIPS FLAT HEAD S/S WOOD SCREW	3/16"	N/A	90H524002

 <p>Hughesville, PA   800.233.8493   570.546.5941 Mississauga, ON   888.895.8955   905.274.3611 <a href="http://www.c-sgroup.com">www.c-sgroup.com</a></p> <p>© Copyright 2019 Construction Specialties, Inc.</p>	<b>PROJECT:</b>	<b>REVISION:</b>
	<b>JOB NO.:</b>	<b>F&amp;F:</b>
	<b>CUSTOMER:</b>	
	<b>REP:</b>	<b>DATE:</b>
	<b>DRAWN BY:</b>	<b>SHEET NO:</b>