

SHOP NOTE: CUT 7/8" OFF END OF RETAINER (TYP. BOTH SIDES)

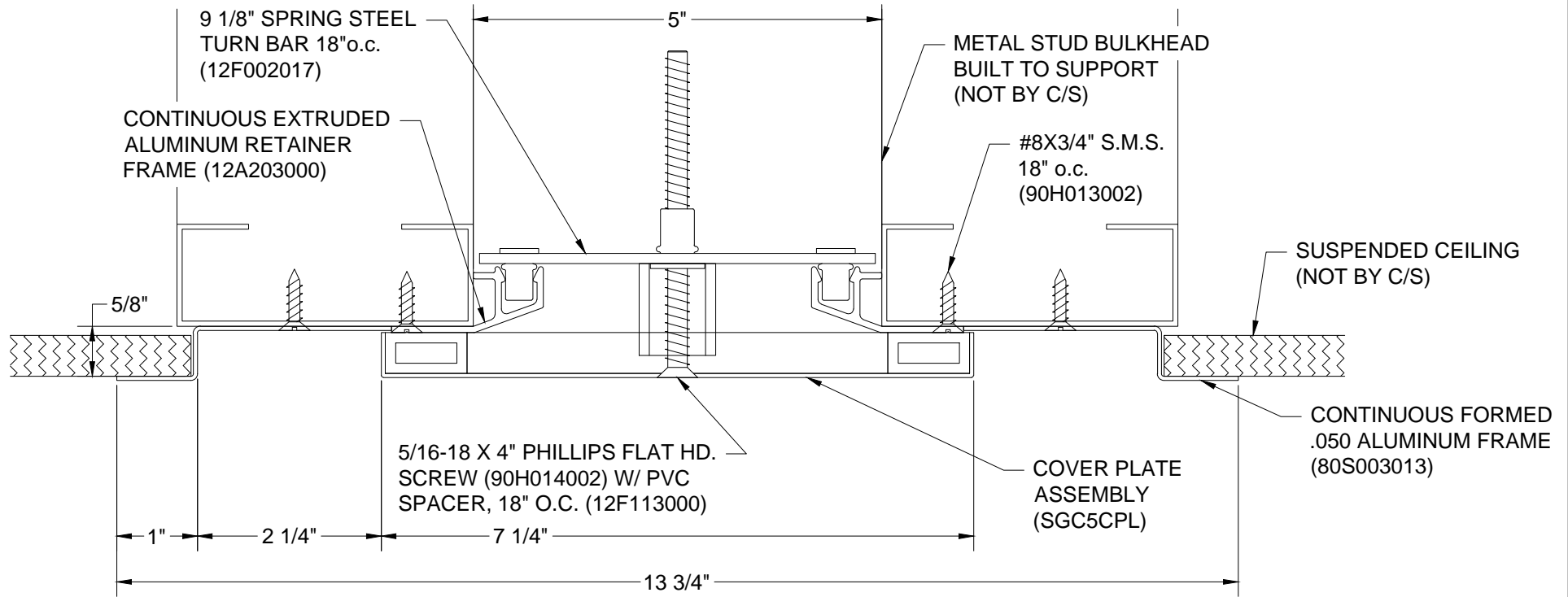

# SGC-500



## Construction Specialties

6696 Route 405 Highway, Muncy, PA 17756  
 Phone (800) 233-8493 / Fax (570) 546-8022  
 895 Lakefront Promenade, Mississauga, Ontario L5E 2C2 Canada  
 Phone (888) 895-8955 / Fax (905) 274-6241

PROJECT:	SCALE: SCALED TO FIT
CUSTOMER:	DATE:
LOCATION:	JOB NO.:
DRAWN BY:	SHEET NO.:

E:\zack\staging\hending\2012-09-25 Updates\Update the SGC & SGW details - Candy Holmer 4-3-12\SGC\sgc5.dwg - 08/2012 10:24 AM - Zachary Parrish