

5/8" STAINLESS STEEL GRIDLINE 2 (RADIUSED RAILS) WITH RECESSED LEVEL BASE FRAME AND BAFFLE

INSERT STYLE: N/A

INSERT COLOR: N/A

CATALOG NUMBER: G6

PART NUMBER:

NO.	REVISION	DATE	BY
NO.	F&F RELEASE	DATE	BY

1/8" X 1-1/4" X 1-1/4" HOLD-DOWN PLATE 1 AT EACH CORNER STARTING ON INSIDE OF OUTER MOST SUPPORT THEN SPACE 36" TO 48" O.C. SLOT SHOULD RUN PARALLEL TO SUPPORTS.

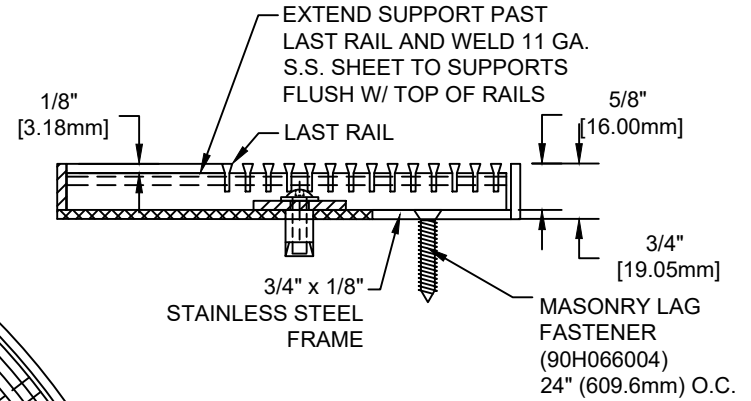
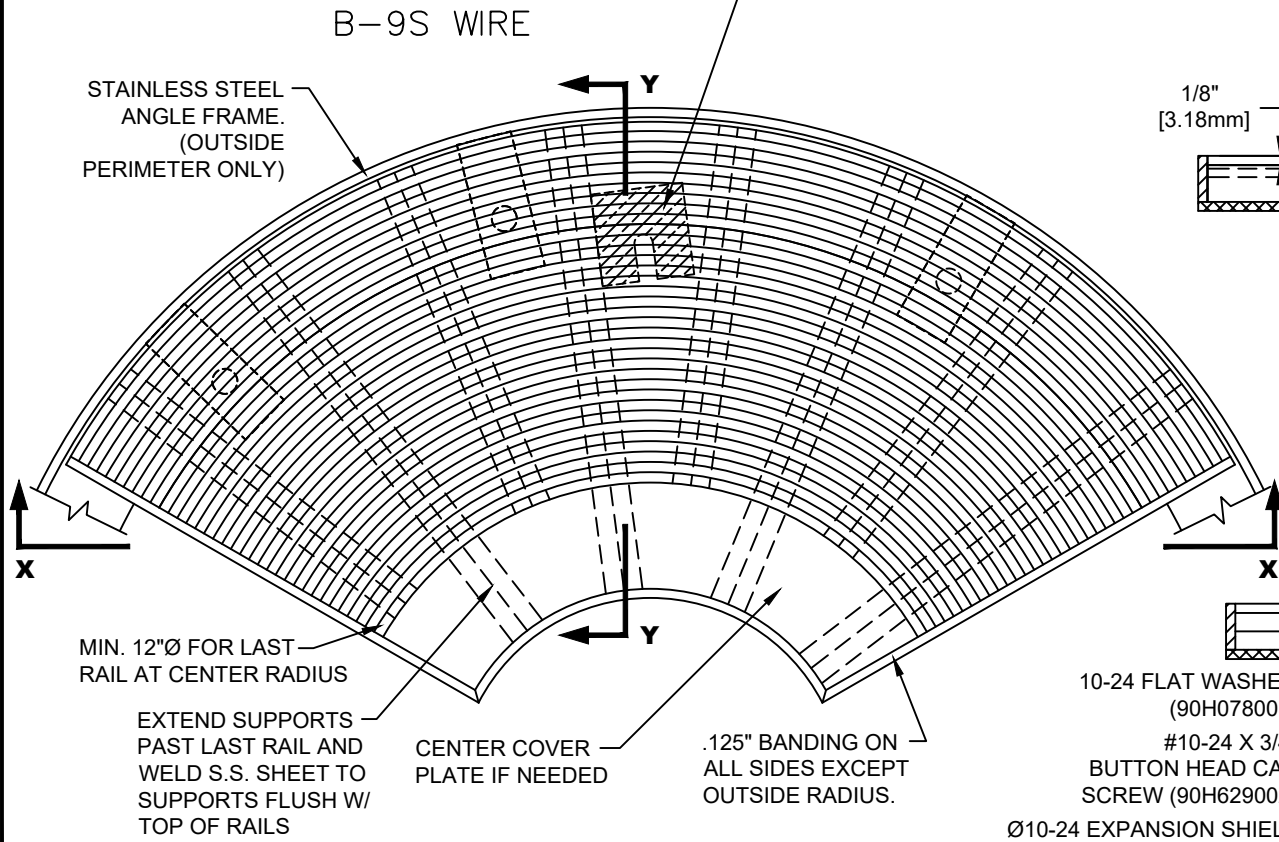

SECTION Y-Y  
NOT TO SCALE

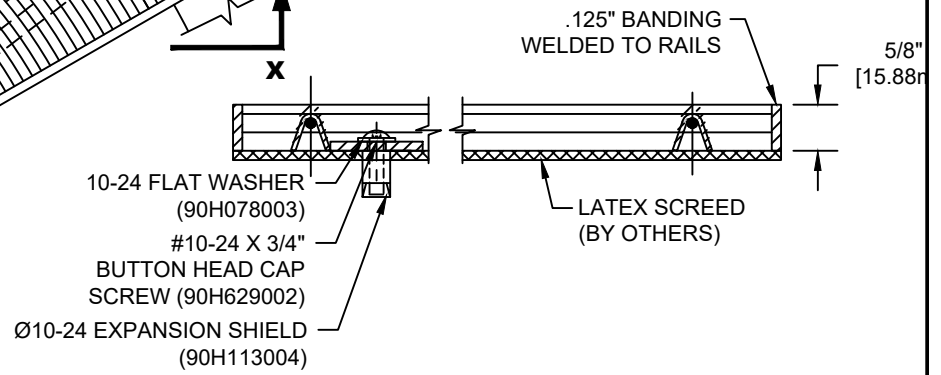

SECTION X-X  
NOT TO SCALE

TYPICAL MODULE PLAN VIEW  
NOT TO SCALE

NOTES:

\* MECHANICALLY INTELLOCKED DESIGN TO ENSURE CORRECT WEIGHT BEARING PROPERTIES.

\* GRIDS SHALL BE ABLE TO SUPPORT A 500LB ROLLING LOAD.

\* SURFACE WIRE SPACING PROVIDES A 57.7% EFFECTIVE OPEN AREA FOR DIRT AND MOISTURE REMOVAL.

**CS Construction Specialties**  
 6696 Route 405 Highway, Muncy PA 17756  
 (800) 233-8493 • Fax (570) 546-4692 • www.c-sgroup.com

PLEASE VERIFY ALL	QTY	MARK #	LOCATION	MODEL	DIM 'A' WIDTH	DIM 'B' LENGTH	REMARKS	

PROJECT:		
LOCATION:		
CONTRACTOR:		
AGENT:		SHT:
DRG. BY:	DATE:	JOB NO.: