

MODEL SJ - HD and SJM-HD INSTALLATION INSTRUCTIONS

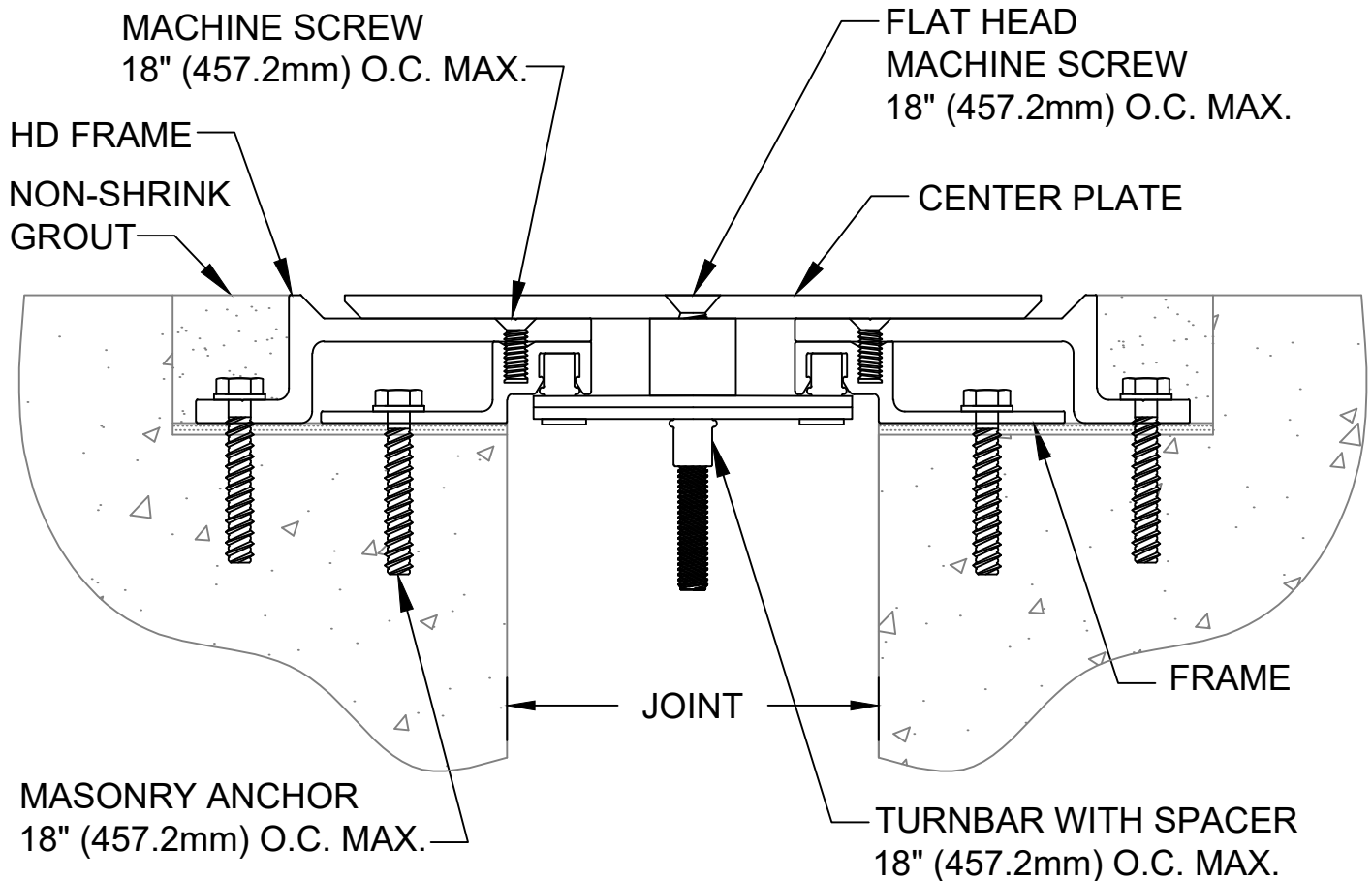

IMPORTANT INFORMATION

Prior to the commencement of Installation, all materials MUST be inspected for Damage. Any damage must be reported to CONSTRUCTION SPECIALTIES, INC., as soon as possible, so that replacement materials may be furnished without delay.

All work must be completed as per Architect's Approved "Shop Drawings", and in accordance with these Installation Instructions. When installation is complete, all materials must be protected from damage until the Architect's FINAL INSPECTION.

All materials should be arranged in the order that they are to be installed. All hardware required for each portion of the work should be placed with the appropriate materials.

Please review all Approved Shop Drawings and this Document to familiarize yourself with all the details and components of this assembly.

IMPORTANT:

READ THROUGH ALL INSTRUCTIONS PRIOR TO STARTING INSTALLATION

11/12/18



Construction Specialties®
www.CSgroup.com

6696 Route 405 Highway, Muncy, PA 17756
Phone: (800) 233-8493 / Fax: (570) 546-8022

This document is the property of Construction Specialties, Inc. and contains PROPRIETARY INFORMATION that is not to be disclosed to third parties and is not to be used without approval in writing from Construction Specialties, Inc.

© Copyright 2016 Construction Specialties, Inc.

Notes

Before beginning installation, review the architectural drawings and approved Construction Specialties Inc. shop drawings to familiarize yourself with the appropriate joint cover models and locations.

Check all of the joint cover components to confirm that the correct joint cover model and size have been received. Also, check for materials that may have been damaged during shipping. Report all incorrect and/or damaged components to CS at 800-233-8493.

Read through all the steps of these instructions prior to beginning work.

STEP 1

PREPARE BLOCKOUTS

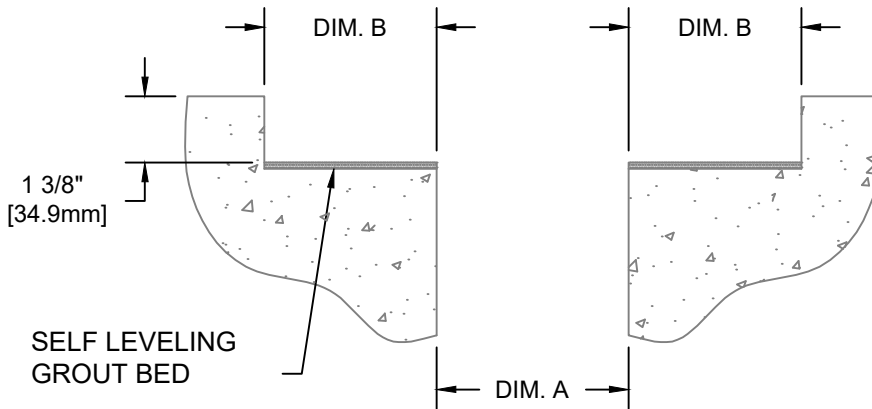

| BLOCKOUT DIMENSIONS | |
|---------------------|------------------|
| DIM. A | DIM. B |
| 1" [25.4mm] | 5-1/8" [130.2mm] |
| 2" [50.8mm] | 4-5/8" [117.5mm] |
| 3" [76.2mm] | 4-1/8" [104.8mm] |
| 4" [101.6mm] | 3-5/8" [92.1mm] |
| 5" [127.0mm] | 3-5/8" [92.1mm] |
| 6" [152.4mm] | 4-1/8" [104.8mm] |
| 7" [177.8mm] | 4-5/8" [117.5mm] |
| 8" [203.2mm] | 4-5/8" [117.5mm] |

- 1.1) The blockouts must be prepared to receive the joint cover.
 - The blockout width (Dim. B) will vary with model as indicated above or as noted on the CS shop drawings.
 - For Model SJ-HD the blockout depth will typically be 1-3/8" (34.9mm). However, the depth may be adjusted as needed to accommodate a floor finish material when required and as indicated on the architectural drawings and/or CS shop drawings.
 - It is recommended that the blockout be formed a minimum of 1/8" deeper to allow the blockouts to be leveled for installation of the joint cover.
 - Apply a self leveling grout to the base of the blockouts to provide a continuous, solid, flat and level base for the joint cover. (Note: The blockouts must be level across the width of the joint.)

STEP 2

SPACER INSTALLATION

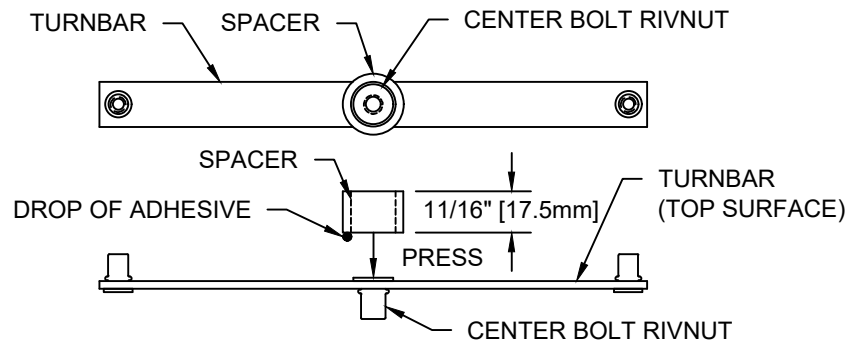

Note: A Spacer must be placed between the turnbar and the underside (or backside) of the cover plate. The Spacer is used to prevent excess bowing of the turnbars when the center bolt is tightened. (Some bowing of the turnbars is required to apply the holding force on the cover plate.)

- 2.1) Place a small drop of "super glue" adhesive (not supplied) onto one end of a Spacer.
- 2.2) Position the end of the Spacer with the adhesive against the top surface of the Turnbar, centered over the flat head portion of the Center Bolt Rivnut. (See detail above.)
- 2.3) Press firmly for a few seconds until the Spacer is bonded to the Turnbar.
- 2.4) Install the Turnbars as instructed.

STEP 3

FRAME INSTALLATION

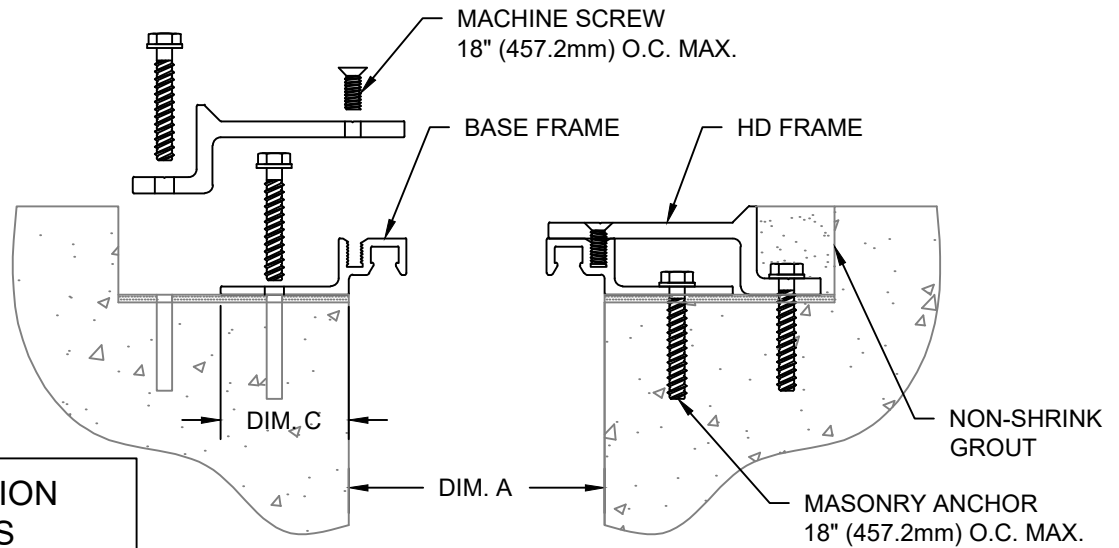

| FRAME LOCATION DIMENSIONS | |
|---------------------------|-----------------|
| DIM. A | DIM. C |
| 1" [25.4mm] | 3-1/2" [88.9mm] |
| 2" [50.8mm] | 3" [76.2mm] |
| 3" [76.2mm] | 2-1/2" [63.5mm] |
| 4" [101.6mm] | 2" [50.8mm] |
| 5" [127.0mm] | 2" [50.8mm] |
| 6" [152.4mm] | 2" [50.8mm] |
| 7" [177.8mm] | 2" [50.8mm] |
| 8" [203.2mm] | 2" [50.8mm] |

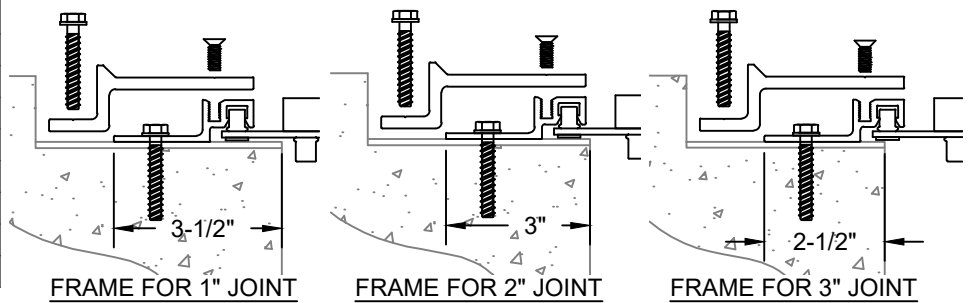

Note:

If a CS Fire Barrier is to be installed in the joint, please review the Fire Barrier Installation Instructions supplied, and if required install the Fire Barrier **BEFORE** installation of CS Seismic Expansion Joint aluminum frames. If Vapor Barrier is to be installed in the joint, please review the Vapor Barrier Installation Instructions supplied, and if required install the Vapor Barrier **BEFORE** installation of CS Seismic Expansion Joint Aluminum Frames. **For all 1", 2" and 3" joints, Turnbars must be installed prior to Frame installation. All Turnbars must be angled in the same direction.**

- 3.1) Begin installation of the Base Frame by placing a length of Frame into the blockout. Cut the Frame to length as needed. The Frame is to sit level, flat and parallel to the edge of the joint.
- 3.2) Refer to the chart above and/or the CS shop drawings for the Base Frame location dimensions.
- 3.3) Using the Base Frame as a template, mark the locations of the anchor bolts.
- 3.4) Remove the Base Frame and drill the holes for the supplied anchor bolts per the manufacturer's guidelines.
- 3.5) Reposition and attach the Base Frame to the slab with the supplied anchor bolts.
- 3.6) Begin installation of the HD Frame by placing a length of HD Frame into the blockout, in the orientation shown above. Cut the HD Frame to length as needed.
- 3.7) Align the machine screw holes of the HD Frame with the screw slot of the Base Frame. Attach the HD Frame to the Base Frame, using one machine screw each end.
- 3.8) Using the HD Frame as a template, mark the locations of the anchor bolts.
- 3.9) Remove the HD Frame and drill the holes for the supplied anchor bolts per the manufacturer's guidelines.
- 3.10) Reposition and attach the HD Frame to the Base Frame with the supplied machine screws.
- 3.11) Anchor the HD Frame to the slab with the supplied anchor bolts following the manufacturer's guidelines.
- 3.12) Repeat this procedure with the HD Frame and Base Frame on the opposite side of the joint and for any additional lengths of frame.

STEP 3A

LEDGE FRAME INSTALLATION

Note: If required, use the following installation instructions to install a Ledge Frame replacing one Base Frame and HD Frame on one side of the joint.

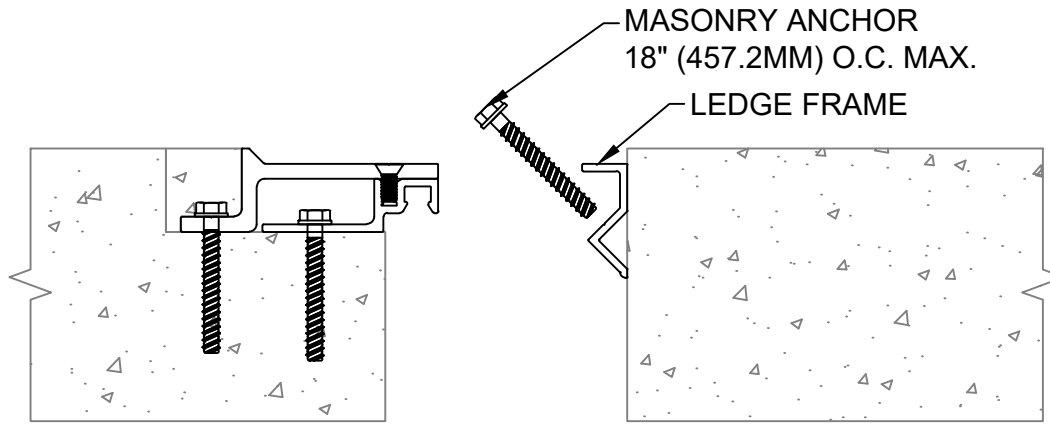

LEDGE FRAME FOR
SJM MODELS

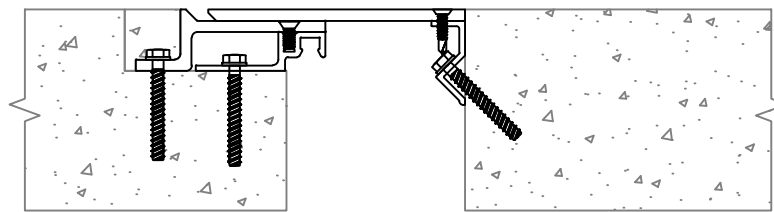

SJM-300HD
MODEL SHOWN

- 3A.1) Begin installation of the Ledge Frame by cutting the frame to the length needed. The Ledge Frame is to sit 1/8" below the finish floor elevation.
- 3A.2) Using the Ledge Frame as a template, mark the locations on the joint wall for the anchor bolts. Remove the Ledge Frame and drill the holes for supplied anchor bolts following the manufacturer's guidelines. Reposition Ledge Frame and anchor to the joint wall.
- 3A.3) Repeat the installation instructions for any additional lengths of Ledge Frame.

STEP 4

GROUT FILL BLOCKOUTS

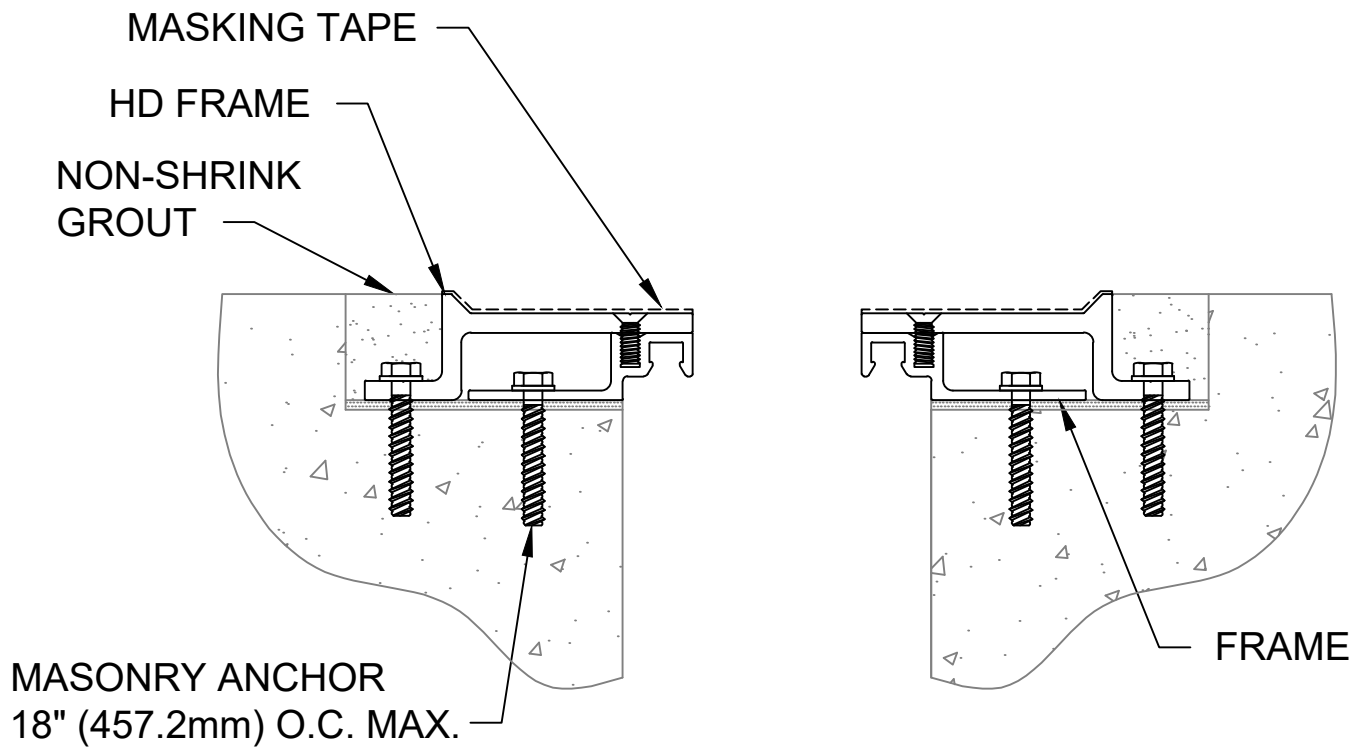

- 4.1) Protect Frames with masking tape.
- 4.2) Apply non-shrink grout in blockout on both sides of the expansion joint. The grout must be poured level with the blockout.
- 4.3) Remove the masking tape after grouting.

***Note: Before beginning the Turnbar installation, review the two different installation methods provided Wedge Block and Tape Installations.

STEP 5 (Tape Method Installation)

TURNBAR TAPE INSTALLATION

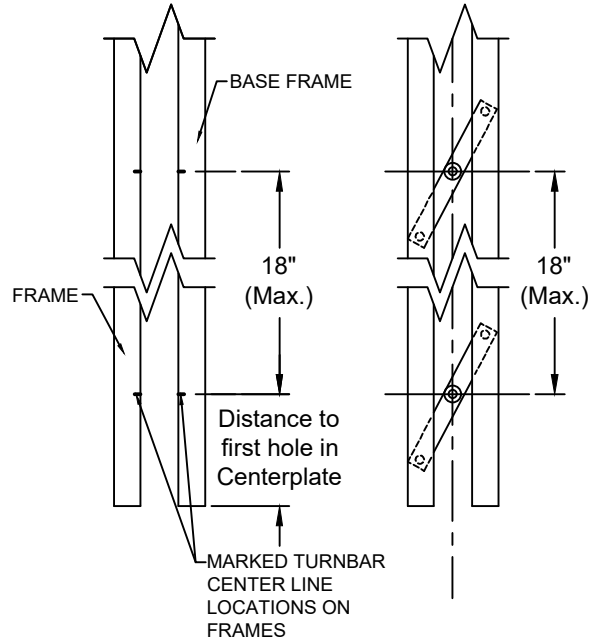
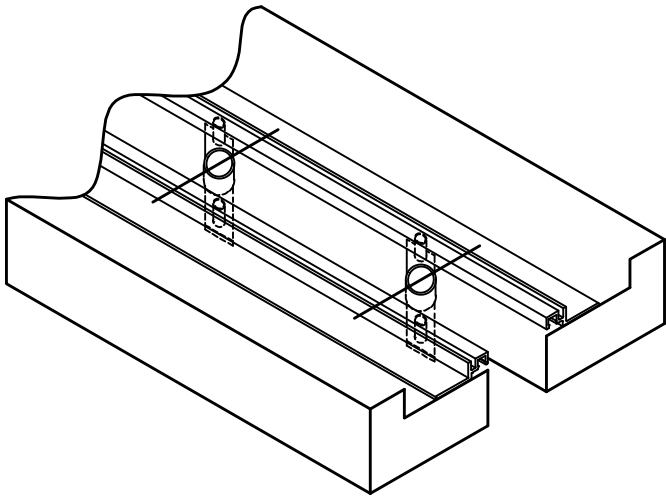

- 5.1) Using the center plate drilled hole locations, measure and mark the Turnbar Centerline locations, on each side of the frame. A maximum of 18" O.C. between turnbar centerlines.
- 5.2) Place the Turnbar pivot pins at each end into the pivot pin receivers of the frame and align Turnbar centerline with the marked locations on the frame. (Note the orientation of the Turnbar in the detail above. Install Turnbar when tightened will rotate in a clock wise motion.) Tape Turnbar in place by attaching tape from the underside to Turnbar up and around to the face of the frame. (See details below) Remove any tape ends that extend above the frame.
- 5.3) Repeat the above steps taping each end of the Turnbar to the frame to hold in place at each Turnbar centerline location on the frames.

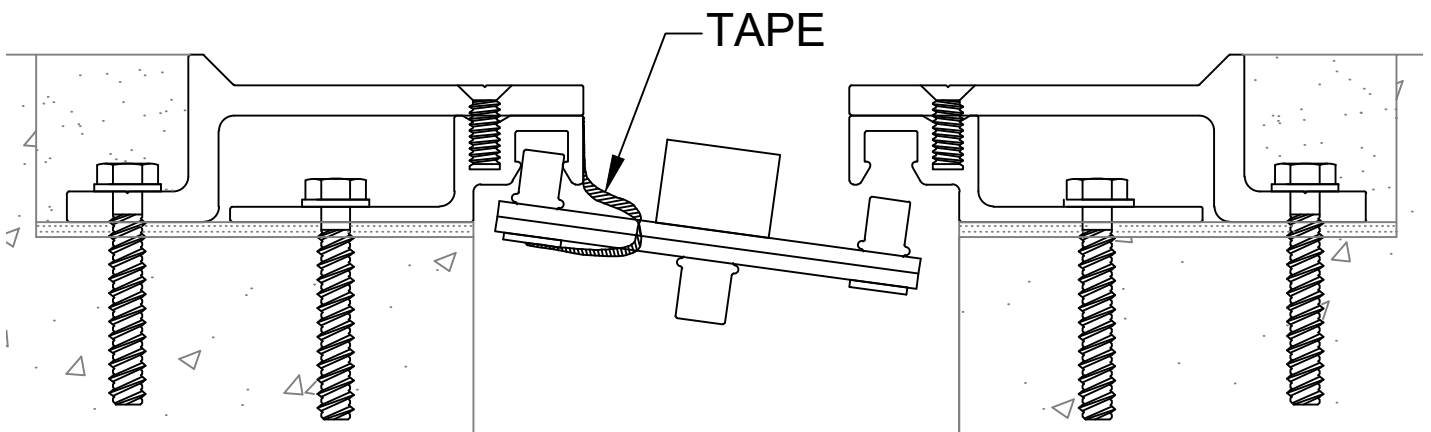

STEP 5 (Tape Method Con't.)

TAPE TURNBAR INSTALLATION

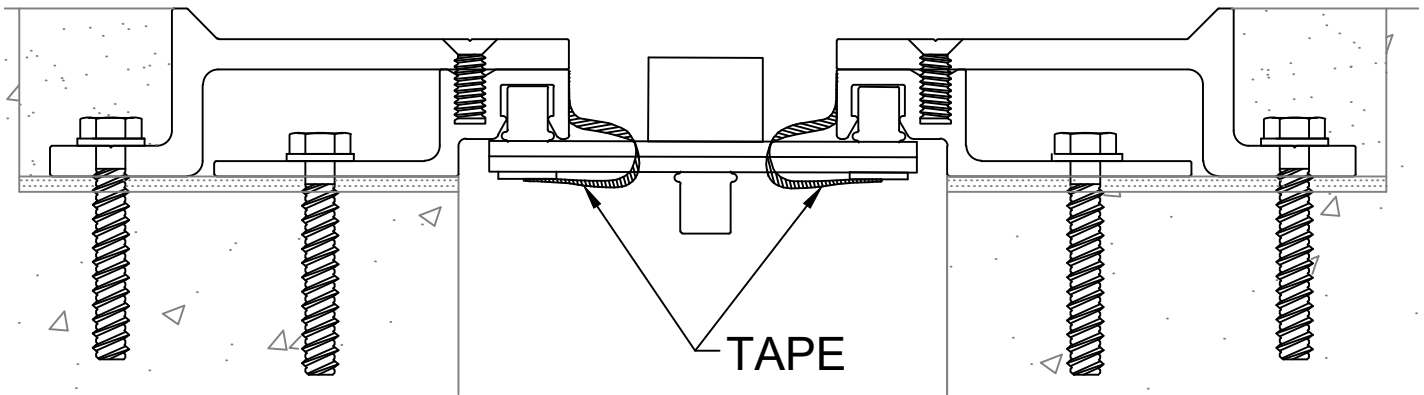

CENTER PLATE INSTALLATION

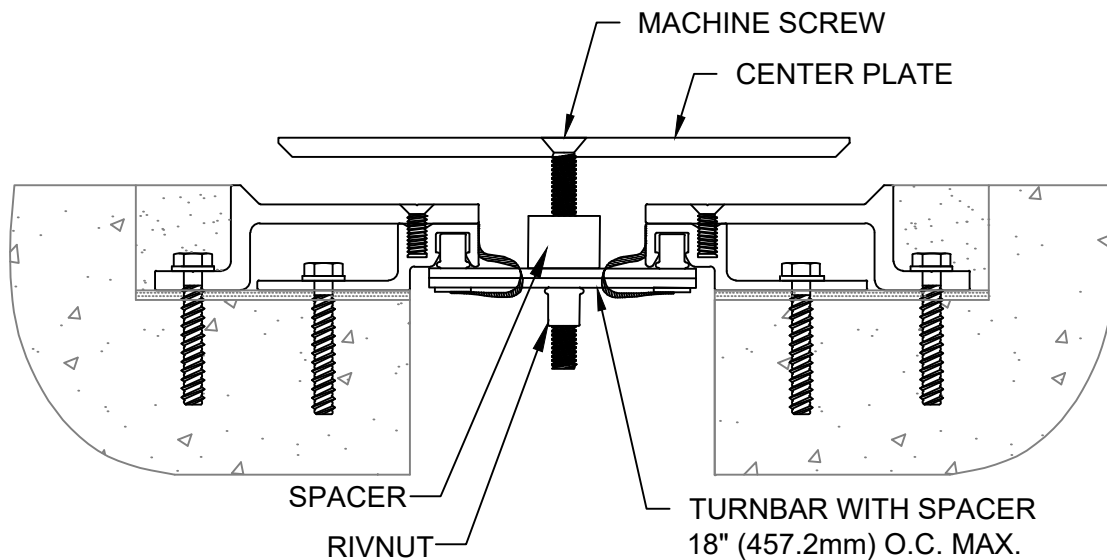

- 5.4) Place the Center Plate over the joint and align the drilled holes with the Turnbar centerlines. Place machine screw into each hole locations tighten only enough to catch the Turnbars. Repeat until all machine screws are in place, then progressively tighten all machine screws until the Center Plate is securely fastened.

STEP 5 (Wedge Block Installation)

***Note: Before beginning the Turnbar installation, review the two different installation methods provided Wedge Block and Tape Installations.

WEDGE BLOCK TURNBAR INSTALLATION

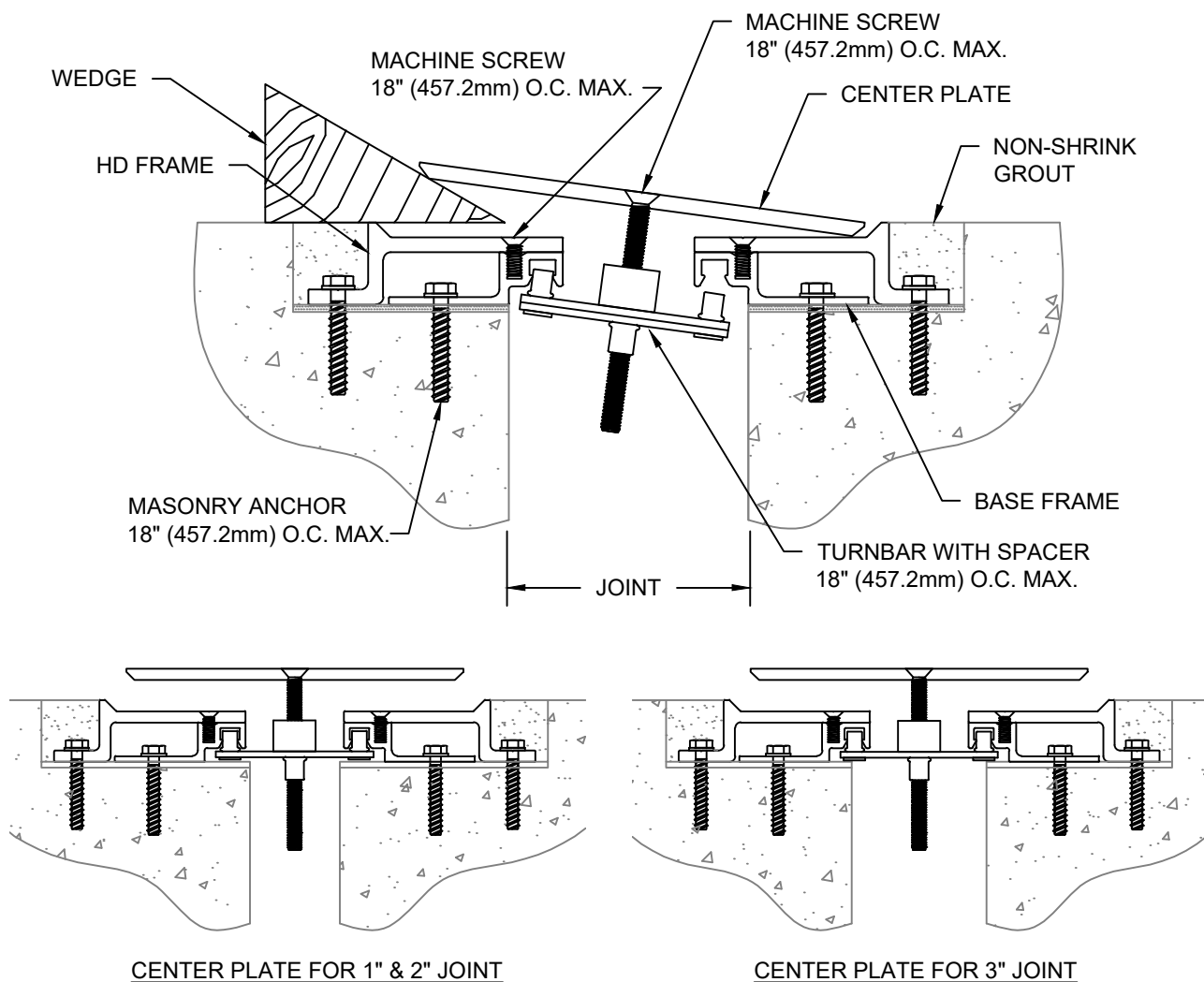

Note: For all 2" and 3" joints:

- Prepare Center Plate for installation by first cutting the Plate to length as needed.
- Position the Center Plate on the Frames over the joint.
- Align the Turnbars with the holes in the Center Plate.
- Attach the Center Plate to the Turnbars using the supplied machine screws 18" (457.2mm) on center maximum.

- 5.1) Prepare the Center Plate for installation by first cutting the Plate to length as needed.
- 5.2) Attach a Turnbar to the backside of the Center Plate at each hole location. (Note the orientation of the Turnbar in the detail above.) Thread a machine screw only approx. 1/4" into the Turnbar for now.
- 5.3) Place the Center Plate/Turnbar Assembly against one side of the Seismic Expansion Joint at an angle that will allow hand penetration behind the Center Plate. With the Center Plate in this position, reach behind the Center Plate and locate the pivot pin of the end Turnbar into the pivot pin receivers of the Frame on each side of the joint.
- 5.4) Slide a wedge block beneath the Center Plate to hold the Turnbar securely into position.
- 5.5) Repeat this procedure with the Turnbar at the opposite end of the Center Plate.
- 5.6) Locate each of the remaining Turnbars into position, then progressively tighten all machine screws until the Center Plate is securely fastened onto the Frame system.

STEP 5

COMPLETE INSTALLATION

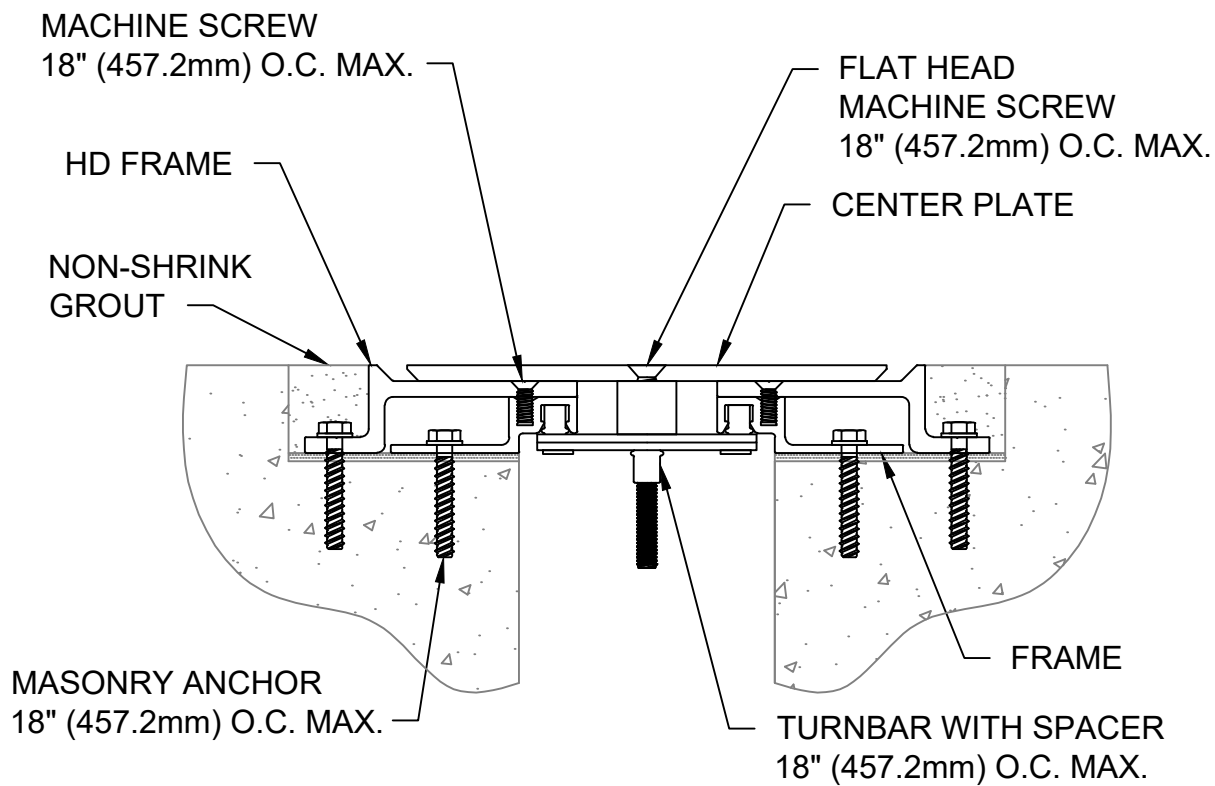

- 5.1) When installation of the Floor Expansion Joint Cover has been completed, remove all residue and foreign matter from the area and joint cover.
- 5.2) Clean the Joint Cover and the adjoining surface with proper cleaner.
- 5.3) Protect the Joint Cover until the Architect's final inspection.