

FWF-M & FWFC-M 200

TECHNICAL DATA:

Aluminum

- Extrusion – CS uses multiple alloys & tempers which are established to be the most appropriate for the given use of individual parts. Will be one of the following: (6063-T5, T6, T52) (6061-T5, T6, T51) (6105-T5, T6) (6005-T5) (6005A-T5, T61), ASTM B221
- Aluminum in contact with concrete/masonry will have a 2 mil heavy metal free high solids primer

Seal

- Dual Durometer 65 Shore-A, 90 Shore-A, ASTM D2000
- Available in 5 colors.

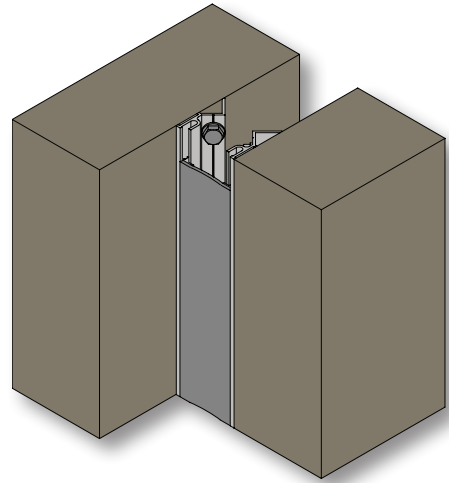

MODEL	JOINT WIDTH	MINIMUM OPENING	MAXIMUM OPENING	EXPOSED SURFACE	BLOCKOUT WIDTH	BLOCKOUT HEIGHT
FWF-200M	2.00" (51mm)	1.00" (25mm)	2.50" (64mm)	2.00" (51mm)	N/A	N/A
FWFC-200M	2.00" (51mm)	1.00" (25mm)	2.50" (64mm)	2.00" (51mm)	N/A	N/A

