

CONTRACTOR NOTES:

1. ALL DIMENSIONS MUST BE FIELD VERIFIED TO A 1/16" TOLERANCE.
2. DIMENSIONS TO BE OBTAINED AT THE ELEVATION OF MATERIAL LOCATION. ALSO, MOUNTING CONDITION TO BE VERIFIED. FABRICATION CANNOT BEGIN WITHOUT THIS INFO.
3. SOME DIMENSIONS SMALLER THAN 16" MAY BE TOO SMALL TO FABRICATE.

NOTES:

1. ALL RAIL TO BE SUPPLIED PREFABRICATED TO REQUIRED LENGTH. ALL CORNERS AND END CAPS TO BE FACTORY FORMED TO SUIT FIELD CONDITIONS.
2. ALL UNITS TO BE PRE-DRILLED FOR ATTACH. HOLE SPACING TO BE DETERMINED BY UNIT LENGTH, SPACING NOT TO EXCEED 32" ON CENTER.
3. ALL MOUNTING HARDWARE TO BE SUPPLIED FOR FIELD ASSEMBLY AND INSTALLATION.
4. MATERIAL:
CS ECR-32S CRASH RAIL SHALL BE MANUFACTURED FROM A 4" WIDE X 1/4" EXTRUSION (#304 STAINLESS STEEL), DESIGNED FOR ELASTIC DEFORMATION UNDER IMPACT WITHOUT DAMAGING THE WALL TO WHICH IT HAS BEEN MOUNTED
5. FINISH:
THE ECR-32S CRASH RAIL SHALL BE FURNISHED WITH A 120 GRIT MECHANICAL #4 SATIN FINISH.

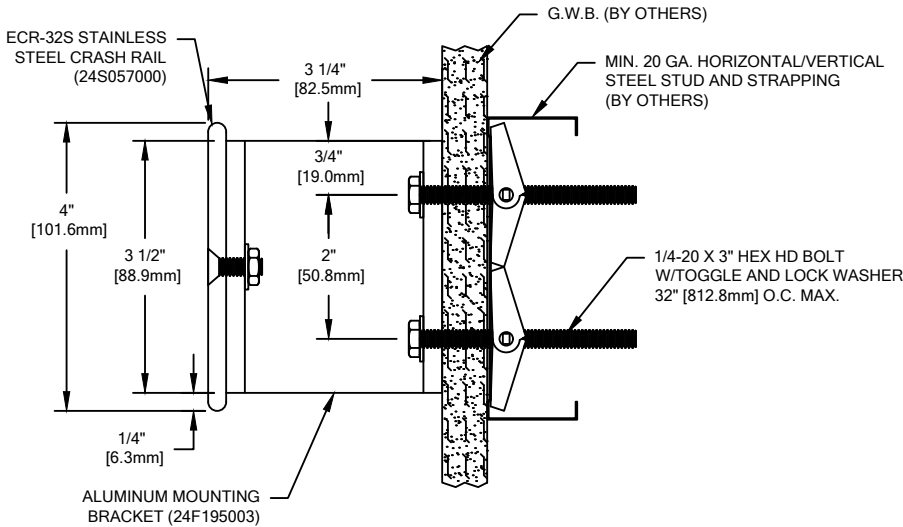

**ECR-32S
"H" BRACKET**

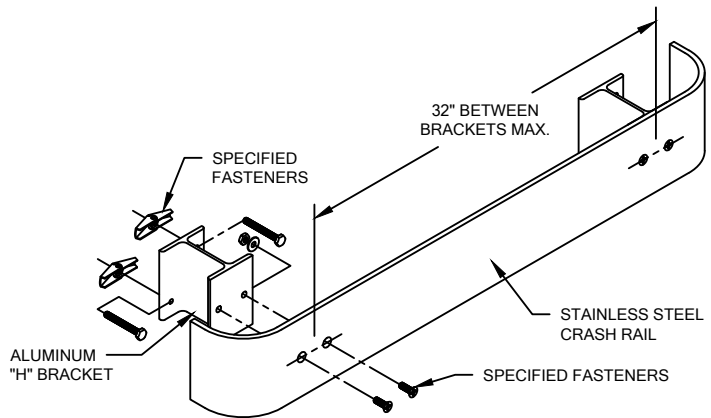

WALL CONDITION	SPECIFIED FASTENER	DRILL DIAMETERS		CS PART NUMBER
		WALL	RETAINER	
STEEL STUD/GYPSUM WALL	1/4-20 X 3" HEX HEAD BOLT 1/4-20 X 2" TOGGLER 1/4" LOCK WASHER	3/4"	N/A	90H281004 90H019004 90H009003
CONCRETE/CONC. BLOCK	1/4-20 X 1 1/2" HEX HEAD BOLT 1/4" LOCK WASHER 1/4-20 X 1 1/4" 4-WAY LEAD SHIELD	1/2"	N/A	90H863002 90H009003 90H020004
WOOD STUD/GYPSUM WALL	1/4 X 3" HEX HEAD LAG SCREW 1/4" LOCK WASHER	3/16"	N/A	90H967002 90H009003

 <p>Hughesville, PA 800.233.8493 570.546.5941 Mississauga, ON 888.895.8955 905.274.3611 www.c-sgroup.com</p> <p>© Copyright 2018 Construction Specialties, Inc.</p>	PROJECT:	REVISION:
	JOB NO.:	F&F:
	CUSTOMER:	
	REP:	DATE:
	DRAWN BY:	SHEET NO: