

**CORNER GUARD:**  
**FINISH:** \_\_\_\_\_  
**THICKNESS:** \_\_\_\_\_  
**TYPE:** \_\_\_\_\_  
 CORNER GUARDS SUPPLIED IN STANDARD .063" THICKNESS, TYPE 5005 H34 ALLOY WITH CLEAR ANODIZE FINISH.  
 OPTIONAL .080" THICKNESS AND TYPE 5005 H34 ALLOY WITH MILL FINISH ARE ALSO AVAILABLE. PLEASE ADVISE IF AN OPTIONAL THICKNESS OR FINISH IS REQUIRED.  
 OPTIONAL POWDER COAT FINISHES ARE AVAILABLE. PLEASE ADVISE OPTIONAL POWDER COAT FINISH IF REQUIRED.

UNITS REQ'D	UNIT HEIGHT	ANGLE	LEG LENGTH	NOSE RAD.

**NOTES:**

- CORNER GUARDS ARE SHIPPED WITH A PROTECTIVE STRIPPABLE COATING.
- ACO-8 CORNER GUARDS HAVE A STANDARD ANGLE OF 90°, LEG LENGTH OF 3 1/2" [89.0mm] AND A STANDARD NOSE RADIUS OF 3/16" [4.8mm]. ACO-8M CORNER GUARDS HAVE A STANDARD ANGLE OF 135°, LEG LENGTH OF 3 1/2" [89.0mm] AND A STANDARD NOSE RADIUS OF 3/16" [4.8mm]. PLEASE ADVISE IF A DIFFERENT LEG LENGTH, ANGLE OR BULL NOSE RADIUS (AVAILABLE IN 1/2" [12.7mm] AND 3/4" [19.15mm] RADIUS) IS DESIRED.
- CORNER GUARDS HAVE A MINIMUM LEG LENGTH OF 1" [25.4mm] AND MINIMUM NOSE RADIUS OF 3/16" [4.8mm].
- ANGLES ONLY AVAILABLE BETWEEN 45° - 178°.
- CORNER GUARDS CAN BE USED AT FULL OR PARTIAL HEIGHTS. PLEASE ADVISE SPECIFIED UNIT HEIGHT.

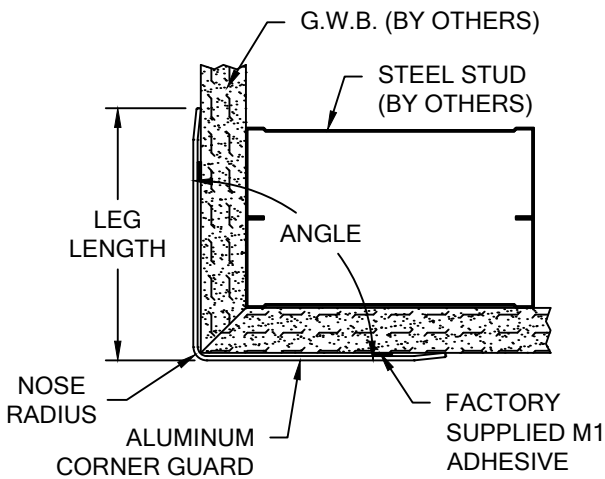

**MODEL: ACO-8**

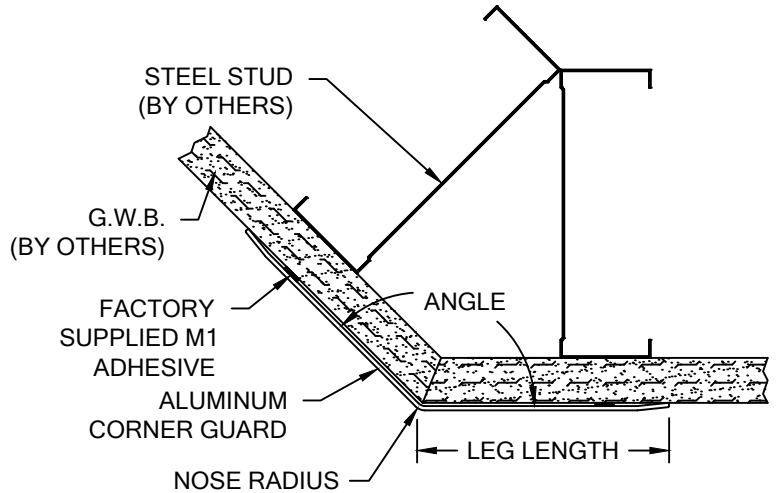

**MODEL: ACO-8M**

**ACO-8 SERIES  
 CORNER GUARD  
 WITH ADHESIVE**

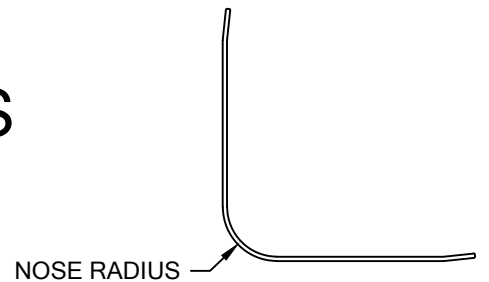

**BULL NOSE RADIUS**

WALL CONDITION	SPECIFIED FASTENER	QUANTITY	CS PART NUMBER
STEEL STUD/GYPSUM WALL CONCRETE/CONC. BLOCK WOOD STUD/GYPSUM WALL	M1 STRUCTURAL ADHESIVE (85 L/F COVERAGE PER TUBE)	28 FL. OZ	90M135001

 Hughesville, PA   800.233.8493   570.546.5941 Mississauga, ON   888.895.8955   905.274.3611 <a href="http://www.c-sgroup.com">www.c-sgroup.com</a> © Copyright 2017 Construction Specialties, Inc.	<b>PROJECT:</b>	<b>REVISION:</b>
	<b>JOB NO.:</b>	<b>F&amp;F:</b>
	<b>CUSTOMER:</b>	
	<b>REP:</b>	<b>DATE:</b>
	<b>DRAWN BY:</b>	<b>SHEET NO:</b>