

CRWS-3 CRASH RAIL

PLEASE READ

PLEASE READ THESE INSTRUCTIONS THOROUGHLY PRIOR TO BEGINNING THE CRWS-3 CRASH RAIL INSTALLATION!

THIS INSTRUCTION SHEET IS INTENDED TO PROVIDE A SPECIFIC GUIDE TO FOLLOW FOR THE INSTALLATION OF THIS CRWS-3 CRASH RAIL. CONTAINED WITHIN IS THE TECHNICAL INFORMATION AND INSTALLATION TECHNIQUES REQUIRED TO COMPLETE AN EFFICIENT, NEAT AND LONG-LASTING INSTALLATION.

INSPECT ALL MATERIALS FOR DAMAGE OR MISSING PARTS. IF YOU DISCOVER DAMAGED OR MISSING MATERIALS, IN THE USA PLEASE NOTIFY THE FACTORY AT (800) 233-8493, AND IN CANADA (888) 895-8955 FOR CUSTOMER SERVICE.

CRWS-3 CRASH RAIL MUST BE INSTALLED IN ACCORDANCE WITH THESE INSTRUCTIONS! FAILURE TO FOLLOW THESE INSTRUCTIONS MAY VOID ANY PRODUCT WARRANTIES AND RESULT IN AN UNSUCCESSFUL INSTALLATION. FOR SPECIFIC QUESTIONS REGARDING THE INSTALLATION OF THIS CRWS-3 CRASH RAIL PLEASE CALL THE FACTORY IN THE USA AT (800) 233-8493 OR EMAIL IWPTECHSUPPORT@C-SGROUP.COM. IN CANADA CALL (888) 895-8955.

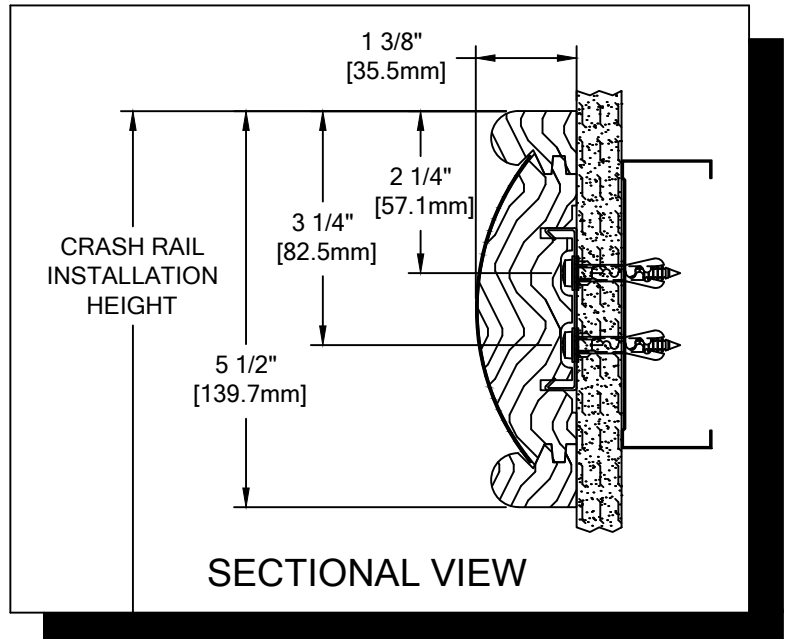

IMPORTANT NOTES

1. THIS MATERIAL HAS BEEN MANUFACTURED TO CUSTOMER SPECIFIED DIMENSIONS AND CAN NOT BE CUT OR MODIFIED ON SITE. TO DO SO COULD VOID THE WARRANTY.
2. DUE TO THE NATURE OF WOOD, COMPONENT COLORS MAY VARY. SORT WOOD COMPONENTS AND MATCH PARTS BY COLOR.
3. ALL DIMENSIONS ARE TYPICAL.
4. FOR DRYWALL/PLASTER WALL CONSTRUCTION, IT IS RECOMMENDED FOR FASTENERS TO BE ENGAGED INTO METAL/WOOD STUDS TO MAINTAIN MAXIMUM PULLOUT STRENGTH. IF DURING INSTALLATION YOU ENCOUNTER SPECIAL WALL CONDITIONS THAT DO NOT ALLOW FOR DIRECT ATTACHMENT TO THE STUDS PLEASE CONSULT THE LOCAL AUTHORITY HAVING JURISDICTION.
5. AF-6 PLASTIC ANCHORS SHOULD SEAT FLUSH WITH GYPSUM WALL.
6. CRASH RAIL SPLICE SHOULD NOT EXCEED 4" [101.6mm] DISTANCE FROM A WALL MOUNT CLIP .
7. MATERIAL MUST REACH 65°F MIN. TO 75° MAX. 24 HOURS PRIOR TO INSTALLATION. THIS IS ESSENTIAL TO MINIMIZE EXPANSION AND CONTRACTION.
8. THIS RAIL REQUIRES A MINIMUM OF 2 MOUNTING BRACKETS PER UNIT. THE MINIMUM END CAP-TO-END CAP CRASH RAIL LENGTH IS 7" [177.8mm].
9. FOR MORE INFORMATION ON CRWS-3 CRASH RAIL SEE OUR WEBSITE AT www.c-sgroup.com.

CRWS-3 CRASH RAIL

COMPONENTS & WALL FASTENERS



WOOD CRASH RAIL

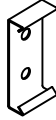

WALL MOUNT CLIP
(24M088000)



STAINLESS STEEL
END CAP
(24S065000)



OPTIONAL WOOD
END CAP
(24W371xxx)



ACCENT REVEAL
(24I113108)



STAINLESS STEEL COVER
(24F214001)



FASTENER #1
#12 X 1" OVAL HD
S/S PH SMS
(90H562002)



FASTENER #2
#10 COUNTERSUNK FLANGED
S/S WASHER
(90H047003)

WALL CONDITION	SPECIFIED FASTENER	DRILL DIAMETERS		CS PART NUMBER
		WALL	RETAINER	
CONCRETE/CONCRETE BLOCK	#10 X 1 1/2" PHILLIPS PAN HEAD SMS AF-6 PLASTIC ANCHORS	1/4"	N/A	90H189002 90H039004
STEEL STUD/GYPSUM WALL	#10 X 1 1/2" PHILLIPS PAN HEAD SMS AF-6 PLASTIC ANCHORS	1/4"	N/A	90H189002 90H039004
WOOD STUD/GYPSUM WALL	#10 x 2-1/4" PHILLIPS PAN HEAD SMS	N/A	N/A	90H421008
20 GA. MIN. STEEL STUD AND 20 GA. MIN. STEEL STRAPPING / GYPSUM WALL CONSTRUCTION REQUIRED (TEK SCREWS)	#6 PHILLIPS PAN HEAD BUGLE HEAD TEK SCREW	N/A	N/A	90H079002

CRWS-3 CRASH RAIL

LAYOUT VIEW

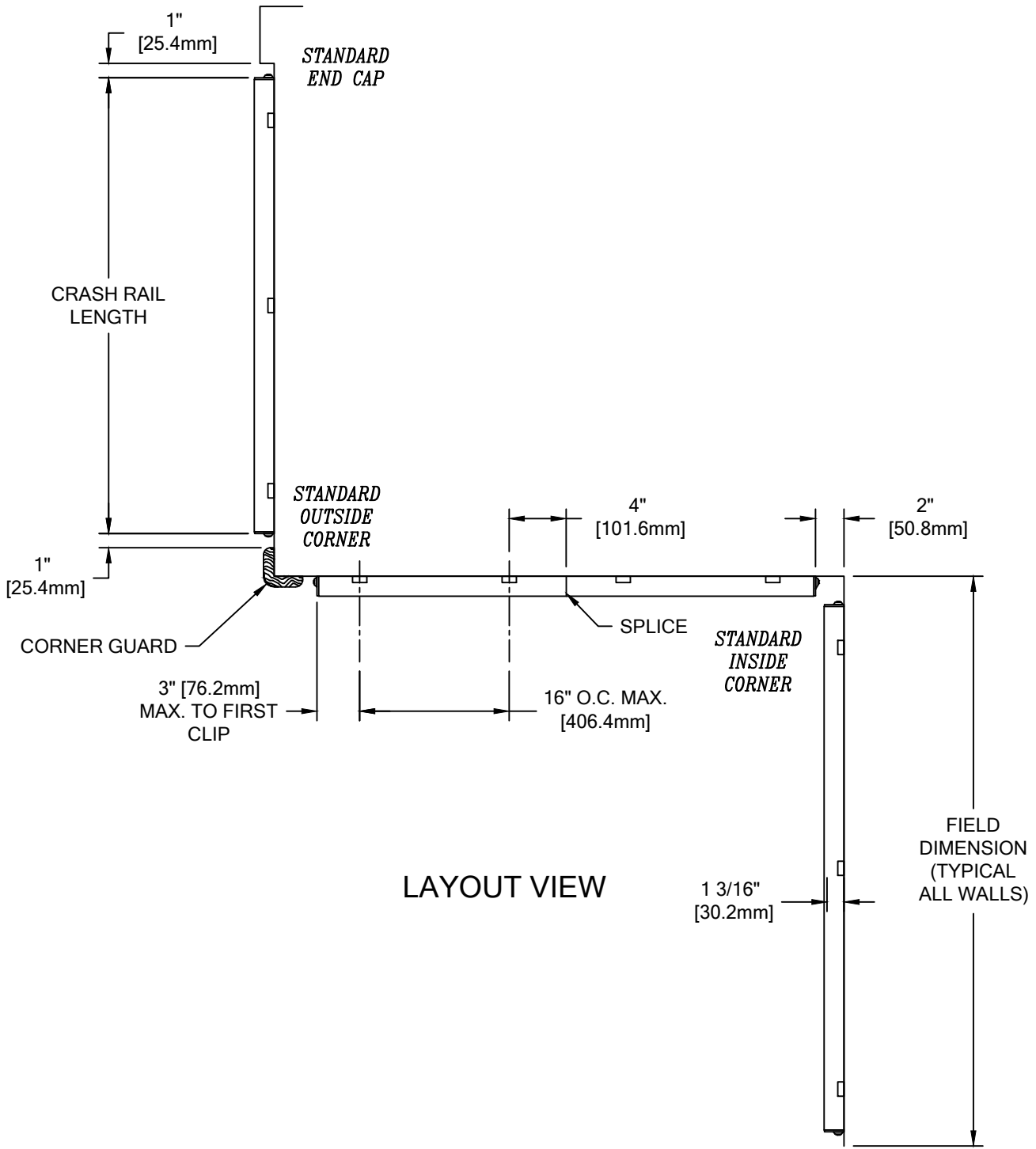

LAYOUT VIEW

CRWS-3 CRASH RAIL

TYPICAL ASSEMBLY

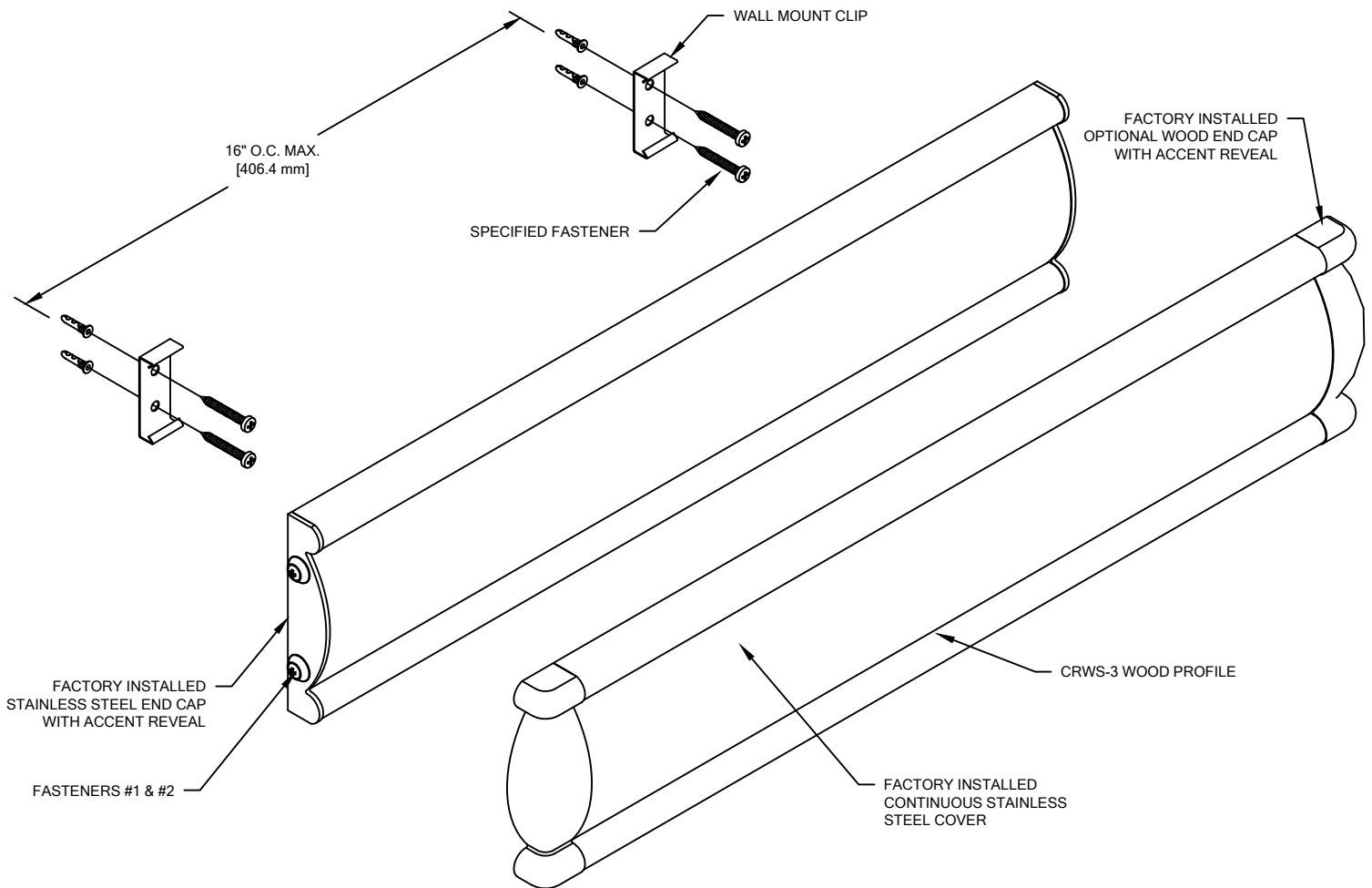

INSTALLING CRASH RAIL:

1. ESTABLISH CRASH RAIL HEIGHT ABOVE FINISH FLOOR. DEDUCT 1 3/8" [34.9mm] AND SNAP A CHALK LINE AT THAT HEIGHT. THIS MARKS THE LOCATION OF THE UPPER ROW OF FASTENERS FOR WALL MOUNT CLIPS.
2. DETERMINE WALL FASTENER LOCATIONS BY USING THE REQUIRED DEDUCTIONS (SEE LAYOUT VIEW) AND DRILL CLEARANCE HOLES IN WALL SURFACE FOR MOUNTING HARDWARE, USING WALL MOUNT CLIP AS A TEMPLATE. SEE CHART ON PAGE 2 FOR CORRECT DRILL DIAMETERS.
3. INSTALL EACH WALL MOUNT CLIP, IN SUCCESSION, USING THE APPROPRIATE FASTENERS. USE A LEVEL TO ENSURE WALL MOUNT CLIPS ARE PLUMB. CAUTION: OVER TIGHTENING FASTENERS WILL DEFORM WALL MOUNT CLIP.

WARNING: BE SURE WALL MOUNT CLIPS AND RAIL ARE IN CORRECT LOCATION. ONCE CRASH RAIL IS INSTALLED, IT WILL BE DIFFICULT TO REMOVE WITHOUT DAMAGING CRASH RAIL. WALL AND/OR WALL MOUNT CLIPS.

4. TO INSTALL CRASH RAIL, BEGIN CLIPPING CRASH RAIL TO WALL AT ONE END AND WORK YOUR WAY DOWN THE LENGTH OF THE RAIL. USE A SOFT RUBBER MALLETT TO TAP THE FACE AT CLIP LOCATIONS TO SEAT THE CRASH RAIL ONTO THE RETAINER CLIPS. BE CAREFUL NOT TO DAMAGE THE CRASH RAIL. SEE SECTIONAL VIEW FOR ALIGNMENT. THOROUGHLY CLEAN CRASH RAIL UPON COMPLETION OF INSTALLATION.

CRWS-3 CRASH RAIL

TYPICAL SPLICE ASSEMBLY

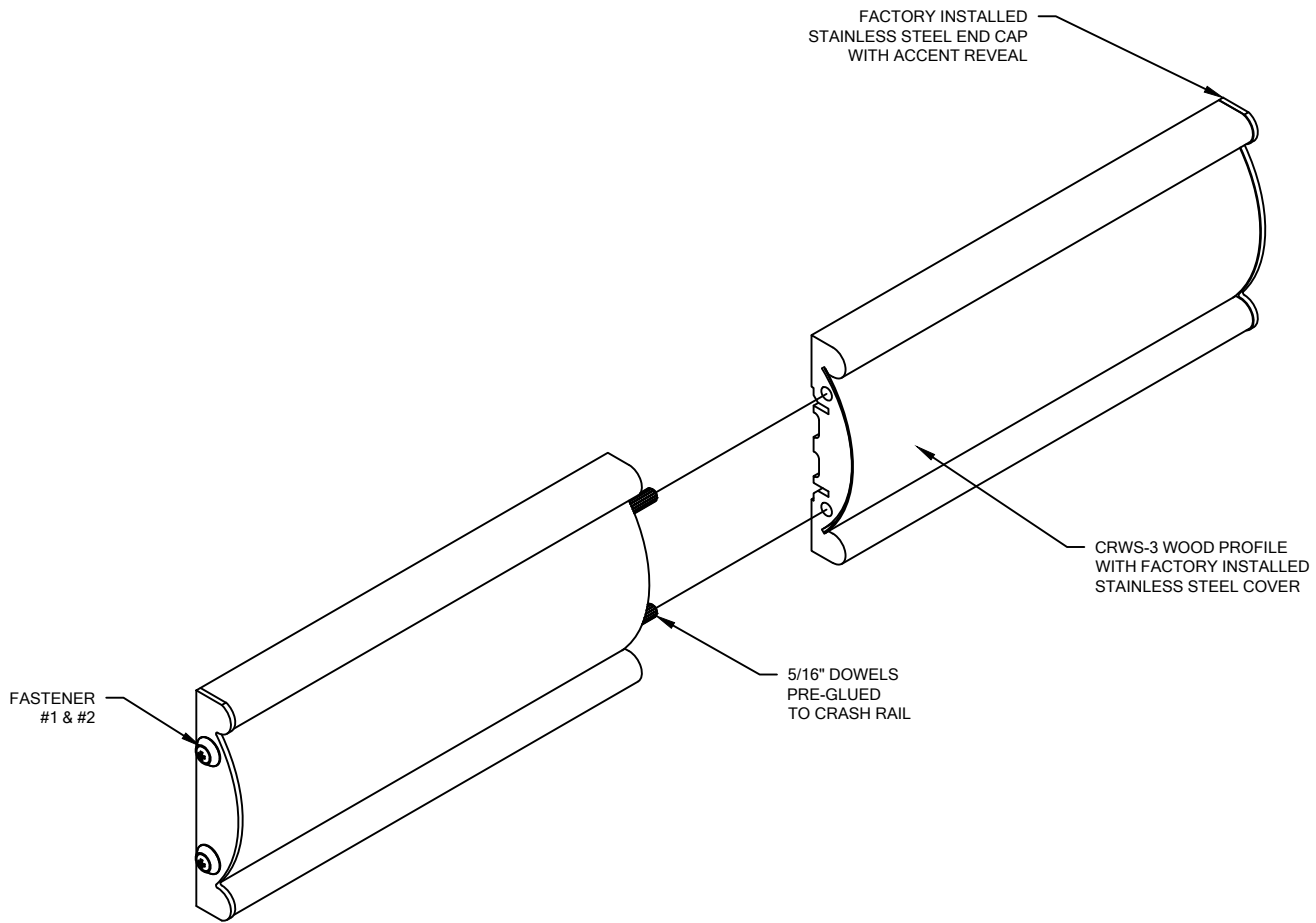

INSTALLING SPLICE:

1. INSTALL ENOUGH WALL MOUNT CLIPS FOR BOTH SECTIONS OF CRASH RAIL. INSTALL FIRST SECTION OF CRASH RAIL.
2. APPLY GLUE TO DOWEL AND PRE-DRILLED HOLES IN CRASH RAILS. TITEBOND WOOD GLUE IS RECOMMENDED FOR THIS APPLICATION.
3. TO INSTALL THE ADJOINING SECTION OF RAIL HOLD IT AT AN ANGLE, WITH MATING END CLOSEST TO WALL. PRESS THIS SECTION OF RAIL FIRMLY AGAINST PRECEDING RAIL (WITHOUT ENGAGING WALL MOUNTING CLIPS) TO CREATE A TIGHT SEAM. WHILE MAINTAINING PRESSURE TOWARDS SEAM, FIRMLY PRESS RAIL ONTO PREVIOUSLY INSTALL WALL MOUNT CLIPS.

WARNING: BE SURE WALL MOUNT CLIPS ARE IN THE CORRECT LOCATION. ONCE CRASH RAIL IS INSTALLED, IT WILL BE DIFFICULT TO REMOVE WITHOUT DAMAGING THE CRASH RAIL, WALL AND/OR WALL MOUNT CLIPS.