

**SCR-48N CRASH RAIL**

PLEASE READ

PLEASE READ THESE INSTRUCTIONS THOROUGHLY PRIOR TO BEGINNING THE SCR-48N CRASH RAIL INSTALLATION!

THIS INSTRUCTION SHEET IS INTENDED TO PROVIDE A SPECIFIC GUIDE TO FOLLOW FOR THE INSTALLATION OF THIS SCR-48N CRASH RAIL. CONTAINED WITHIN IS THE TECHNICAL INFORMATION AND INSTALLATION TECHNIQUES REQUIRED TO COMPLETE AN EFFICIENT, NEAT AND LONG-LASTING INSTALLATION.

INSPECT ALL MATERIALS FOR DAMAGE OR MISSING PARTS. IF YOU DISCOVER DAMAGED OR MISSING MATERIALS, IN THE USA PLEASE NOTIFY THE FACTORY AT (800) 233-8493, AND IN CANADA (888) 895-8955 FOR CUSTOMER SERVICE.

SCR-48N CRASH RAIL MUST BE INSTALLED IN ACCORDANCE WITH THESE INSTRUCTIONS! FAILURE TO FOLLOW THESE INSTRUCTIONS MAY VOID ANY PRODUCT WARRANTIES AND RESULT IN AN UNSUCCESSFUL INSTALLATION. FOR SPECIFIC QUESTIONS REGARDING THE INSTALLATION OF THIS SCR-48N CRASH RAIL PLEASE CALL THE FACTORY IN THE USA AT (800) 233-8493 OR EMAIL IWPTECHSUPPORT@C-SGROUP.COM. IN CANADA CALL (888) 895-8955.

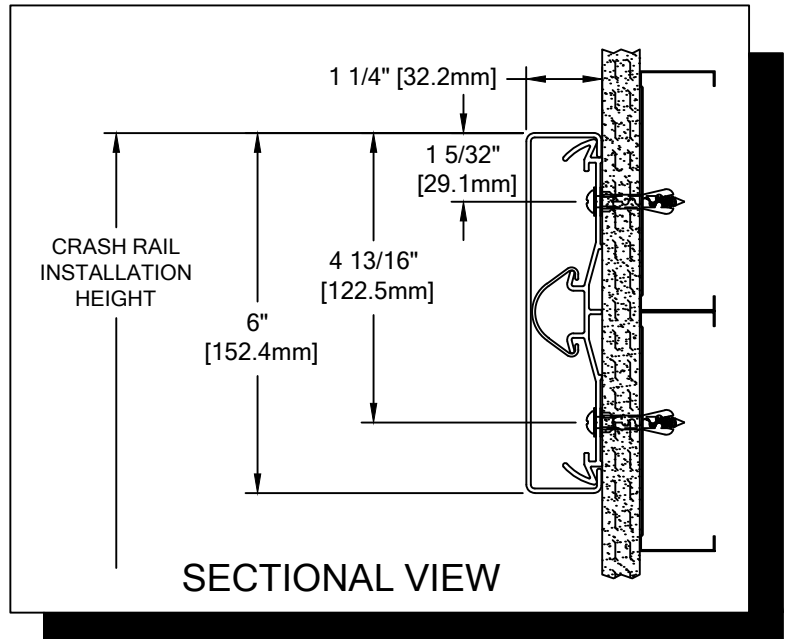

IMPORTANT NOTES

1. ALL LINEAL MATERIAL TO BE SUPPLIED IN STOCK LENGTHS. ACROVYN IN LENGTHS UP TO 20'-0". THIS MATERIAL IS TO BE FIELD CUT USING QUALITY EQUIPMENT TO INSURE THAT ALL CUTS ARE SQUARE. WHEN CUTTING MATERIAL SECTIONS, C/S RECOMMENDS USING AN 80-100 TOOTH CARBIDE TIPPED SAW BLADE OR EQUIVALENT, TO MINIMIZE CHIPPING AND MAINTAIN JOINT ALIGNMENT.
2. RADIAL MATERIAL MAY BE SUPPLIED FACTORY FORMED OR IN STRAIGHT LENGTHS FOR FIELD FORMING. CONSULT FACTORY FOR OPTIONS.
3. ALL DIMENSIONS ARE TYPICAL.
4. FOR DRYWALL/PLASTER WALL CONSTRUCTION, IT IS RECOMMENDED FOR FASTENERS TO BE ENGAGED INTO METAL/WOOD STUDS TO MAINTAIN MAXIMUM PULLOUT STRENGTH. IF DURING INSTALLATION YOU ENCOUNTER SPECIAL WALL CONDITIONS THAT DO NOT ALLOW FOR DIRECT ATTACHMENT TO THE STUDS PLEASE CONSULT THE LOCAL AUTHORITY HAVING JURISDICTION.
5. AF-6 PLASTIC ANCHORS SHOULD SEAT FLUSH WITH GYPSUM WALL.
6. MATERIAL MUST REACH 65°F MIN. TO 75°F MAX. 24 HOURS PRIOR TO INSTALLATION. THIS IS ESSENTIAL TO MINIMIZE EXPANSION AND CONTRACTION OF MATERIAL.
7. THE DISTANCE BETWEEN AN ACROVYN SPLICE JOINT AND REGRIND BUMPER CUSHION JOINT SHOULD BE STAGGERED 1" [25.4mm] OVER ALUMINUM SPLICE CLIP.
8. TANGENT POINTS ON FACTORY FORMED RADIAL MATERIAL WILL BE MARKED APPROXIMATELY AND SHOULD BE CUT TO SUIT FIELD CONDITIONS.
9. THIS CRASH RAIL REQUIRES A MINIMUM OF 2 RETAINER CLIPS PER UNIT. THE MINIMUM END CAP-TO-END CAP CRASH RAIL LENGTH IS 6 5/8" [168.3mm].
10. FOR MORE INFORMATION ON SCR-48N CRASH RAIL SEE OUR WEBSITE AT [www.c-sgroup.com](http://www.c-sgroup.com).

**SCR-48N CRASH RAIL**

COMPONENTS & WALL FASTENERS



ACROVYN COVER  
(24U031xxx)  
ACROVYN WOODGRAINS  
AND BRUSHED METALS COVER  
(24U682xxx)



1 1/2" ALUMINUM  
RETAINER CLIP  
(24F234001)

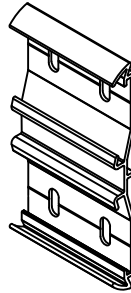

3" ALUMINUM  
SPLICE CLIP  
(24F235002)



REGRIND BUMPER CUSHION  
(24U804108)



ACROVYN SPLICE COVER  
(24F227108)

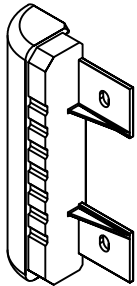

CRASH RAIL END CAP  
(24I119xxx)  
ACROVYN WOODGRAINS  
AND BRUSHED METALS END CAP  
(24I986xxx)

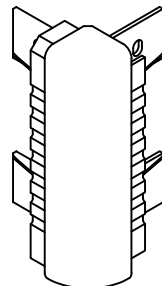

CRASH RAIL OUTSIDE  
CORNER ASSEMBLY

WALL CONDITION	SPECIFIED FASTENER	DRILL DIAMETERS		C/S PART NUMBER
		WALL	RETAINER	
STEEL STUD/GYPSUM WALL	#10 X 1 1/2" PHILLIPS PAN HEAD SMS 1/4" FLAT WASHER SAE AF-6 PLASTIC ANCHOR	1/4"	N/A	90H189002 90H007003 90H039004
CONCRETE/CONCRETE BLOCK	#10 X 1 1/2" PHILLIPS PAN HEAD SMS 1/4" FLAT WASHER SAE AF-6 PLASTIC ANCHOR	1/4"	N/A	90H189002 90H007003 90H039004
WOOD STUD/GYPSUM WALL	#10 x 2-1/4" PHILLIPS PAN HEAD SMS 1/4" FLAT WASHER SAE	N/A	N/A	90H421008 90H007003
20 GA. MIN. STEEL STUD AND 20 GA. MIN. STEEL STRAPPING / GYPSUM WALL CONSTRUCTION REQUIRED (TEK SCREWS)	#6 PHILLIPS BUGLE HEAD TEK SCREW	N/A	N/A	90H079002

SCR-48N CRASH RAIL

LAYOUT VIEW

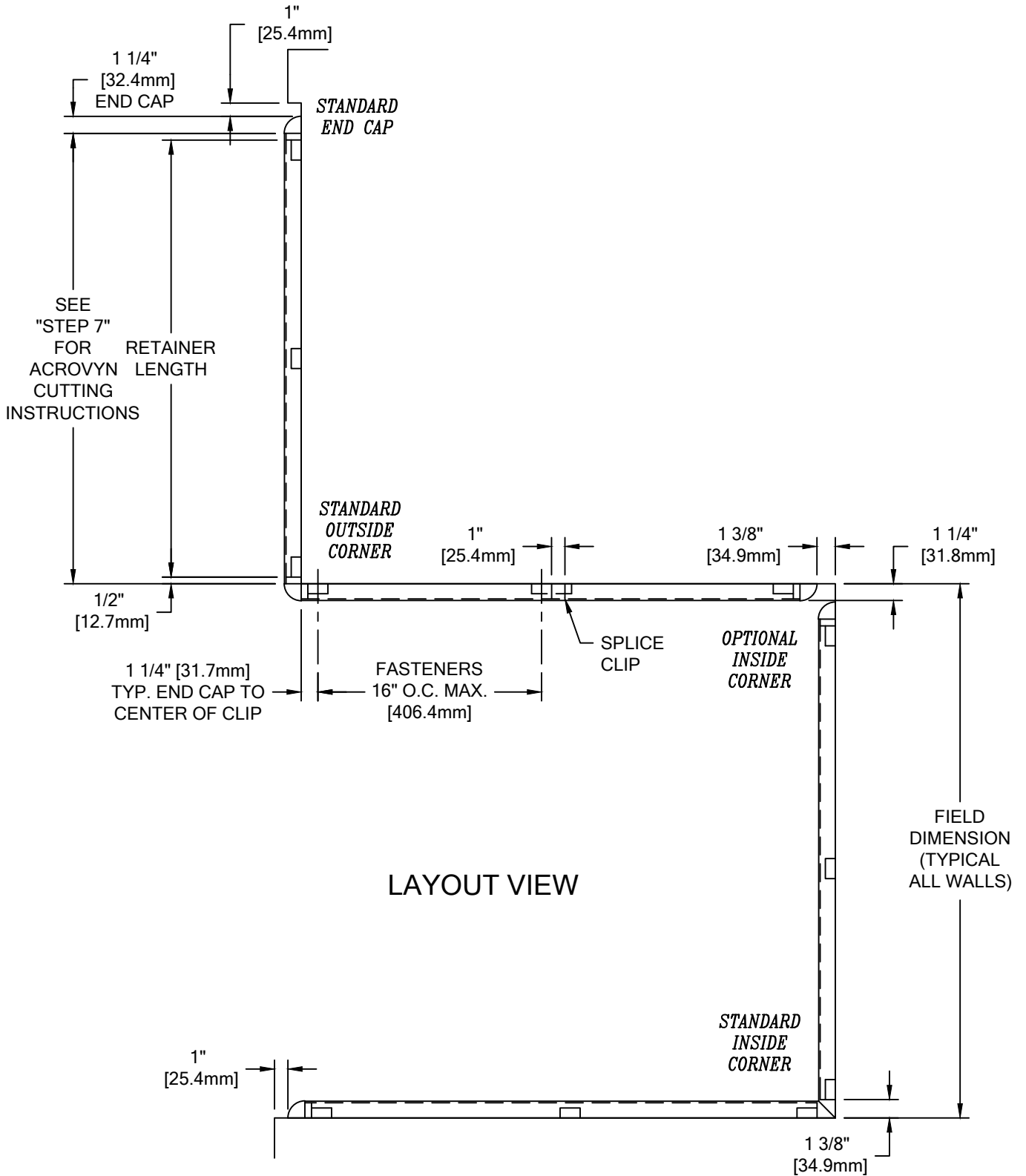

LAYOUT VIEW

**SCR-48N CRASH RAIL**

TYPICAL ASSEMBLY

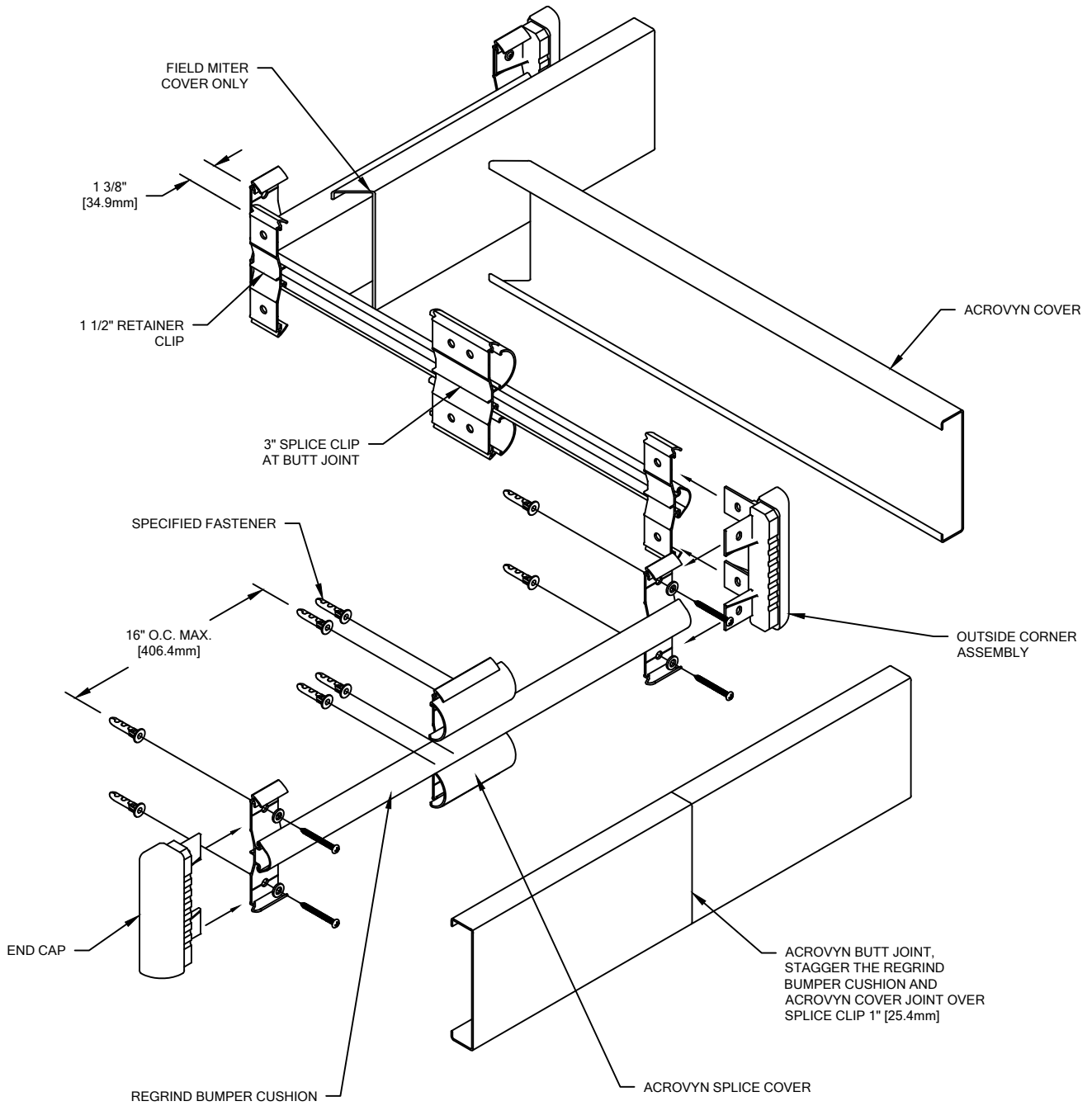

**SCR-48N CRASH RAIL**

SPLICE COVER ASSEMBLY

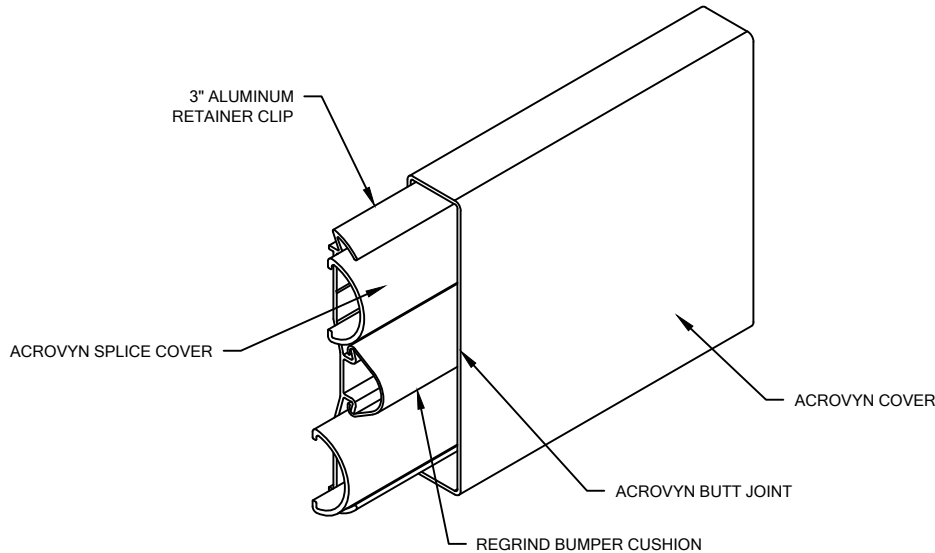

**NOTE:** INSTALLATION OF LINEAL OR RADIAL SCR-48N CRASH RAIL SHOULD BE DONE IN ACCORDANCE WITH THE FOLLOWING INSTRUCTIONS.

1. ESTABLISH CRASH RAIL HEIGHT ABOVE FINISH FLOOR. DEDUCT 1 5/32" [29.4mm] AND 4 13/16" [122.2mm] AND SNAP A CHALK LINE AT THAT HEIGHT. THIS MARKS THE LOCATION OF THE RETAINER CLIP FASTENERS. (SEE SECTIONAL VIEW)
2. DETERMINE AND MARK THE LOCATION OF THE CLIPS BY USING THE REQUIRED DEDUCTIONS (SEE LAYOUT VIEW). ALIGN THE CENTER OF THE TOP MOUNTING CLIP HOLES WITH THE CHALK LINE ESTABLISHED IN "STEP 1". USING THE CLIPS AS A TEMPLATE, MARK THE LOCATION OF THE TOP AND BOTTOM FASTENERS. DRILL CLEARANCE HOLES FOR THE MOUNTING HARDWARE. REFERENCE CHART ON PAGE 2 FOR CORRECT DRILL DIAMETERS.
3. INSTALL ALL END CAPS/OUTSIDE CORNERS AS PER STANDARD DEDUCTIONS (SEE LAYOUT VIEW), BY SLIDING THE END CAP/OUTSIDE CORNER ONTO THE 1 1/2" [38.1mm] RETAINER CLIP. SECURE INTO POSITION USING THE APPROPRIATE FASTENERS (SEE CHART ON PAGE 2).

**NOTE:** TO AID IN LOCATING THE END CAPS CORRECTLY, CUT A 4" [101.6mm] SECTION OF COVER FROM SCRAP AND SNAP IT ON THE CLIPS. LOCATE THE CAP SO IT ALIGNS FLUSH WITH THE TOP AND BOTTOM OF THE COVER.

4. FASTEN CLIPS TO WALL USING THE APPROPRIATE FASTENERS. 1 1/2" [38.1mm] CLIPS ARE TO BE INSTALLED AT 16" [406.4mm] O.C. AND 3" [76.2mm] CLIPS ARE TO BE INSTALLED AT ALL BUTT JOINTS. USE A LEVEL TO INSURE THE CLIPS AND SPLICES ARE INSTALLED PLUMB.
5. CUT THE REGRIND BUMPER CUSHION TO LENGTH NOTING THE REQUIRED DEDUCTIONS (SEE LAYOUT VIEW) AND INSTALL ONTO THE ALUMINUM RETAINER CLIPS.

**NOTE:** WHEN FIELD FORMING RADIUS CRASH RAIL, BE SURE TO APPLY NEEDED PRESSURE FROM CLIP TO CLIP.

6. ATTACH THE ACROVYN SPLICE COVERS AT ALL SPLICE JOINTS BY SNAPPING THEM INTO PLACE ABOVE AND BELOW THE REGRIND BUMPER CUSHION.
7. CUT THE ACROVYN COVER TO THE PROPER LENGTH. THE COVER LENGTH IS DETERMINED BY MEASURING THE DISTANCE BETWEEN THE INSTALLED END CAPS AND/OR OUTSIDE CORNERS.

**NOTE:** IT IS RECOMMENDED THAT THE ACROVYN COVERS BE CUT WITH AN 80-100 TOOTH CARBIDE TIPPED SAW BLADE OR EQUIVALENT.

**NOTE:** IT IS RECOMMENDED THAT THE ACROVYN COVERS BE CUT SLIGHTLY LONGER (1/32" UP TO 5'-0", 1/16" OVER 5'-0") THAN THE MEASURED DISTANCE. THIS ADDITIONAL LENGTH WILL PROVIDE FOR A TIGHTER COVER-TO-END CAP FIT.

8. ALIGN THE TOP OF THE ACROVYN COVER WITH THE TOP OF THE RETAINER CLIPS AND SNAP THE COVER ONTO THE BOTTOM SECTION OF THE RETAINER CLIPS.

**NOTE:** MANUFACTURER RECOMMENDS ALL PRINTED "PRODUCT IDENTIFICATION" ON THE REAR OF THE ACROVYN PROFILE SHALL BE ORIENTED IN THE SAME DIRECTION DURING INSTALLATION TO ENSURE PROPER ALIGNMENT AT SPLICE BUTT JOINTS.