

HRWS-6C HANDRAIL

WITH WOOD END CAPS

PLEASE READ

PLEASE READ THESE INSTRUCTIONS THOROUGHLY PRIOR TO BEGINNING THE HRWS-6C HANDRAIL INSTALLATION!

THIS INSTRUCTION SHEET IS INTENDED TO PROVIDE A SPECIFIC GUIDE TO FOLLOW FOR THE INSTALLATION OF THIS HRWS-6C HANDRAIL. CONTAINED WITHIN IS THE TECHNICAL INFORMATION AND INSTALLATION TECHNIQUES REQUIRED TO COMPLETE AN EFFICIENT, NEAT AND LONG-LASTING INSTALLATION.

INSPECT ALL MATERIALS FOR DAMAGE OR MISSING PARTS. IF YOU DISCOVER DAMAGED OR MISSING MATERIALS, IN THE USA PLEASE NOTIFY THE FACTORY AT (800) 233-8493, AND IN CANADA (888) 895-8955 FOR CUSTOMER SERVICE.

HRWS-6C HANDRAIL MUST BE INSTALLED IN ACCORDANCE WITH THESE INSTRUCTIONS! FAILURE TO FOLLOW THESE INSTRUCTIONS MAY VOID ANY PRODUCT WARRANTIES AND RESULT IN AN UNSUCCESSFUL INSTALLATION. FOR SPECIFIC QUESTIONS REGARDING THE INSTALLATION OF THIS HRWS-6C HANDRAIL, PLEASE CALL THE FACTORY IN THE USA AT (800) 233-8493 OR EMAIL IWPTECHSUPPORT@C-SGROUP.COM. IN CANADA CALL (888) 895-8955.

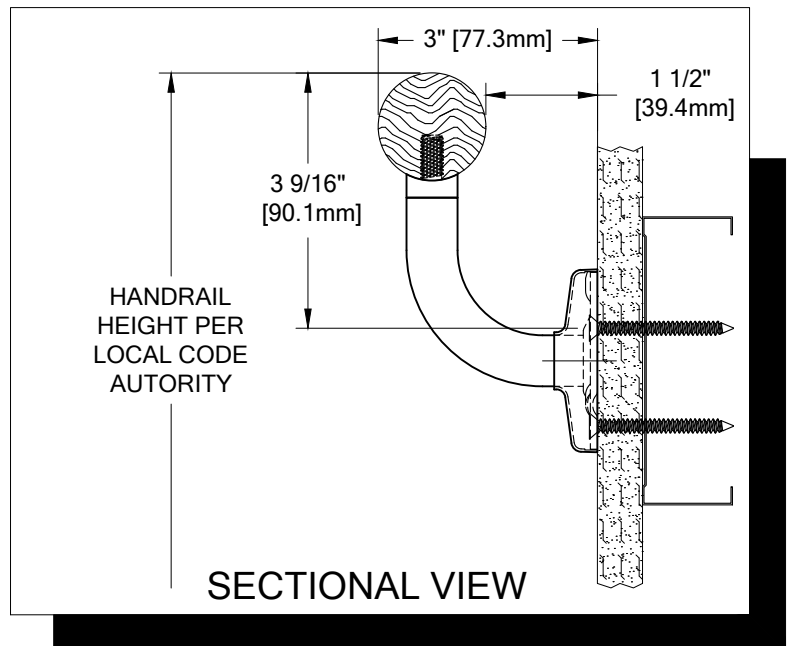

IMPORTANT NOTES

1. DUE TO WOOD BEING A NATURAL PRODUCT, COMPONENTS MAY GROW AND SHRINK AT DIFFERENT RATES. BECAUSE OF THIS, C/S HAS DESIGNED THIS HANDRAIL TO UTILIZE A BEVEL AS SHOWN IN THESE INSTRUCTIONS (SEE FIGURE 1). THIS BEVEL MUST BE APPLIED AT ALL WOOD JOINTS AND MUST MATCH FACTORY BEVEL ON END CAPS.
2. DUE TO THE NATURE OF WOOD, COMPONENT COLORS MAY VARY. SORT WOOD COMPONENTS AND MATCH PARTS BY COLOR.
3. ALL WOOD HANDRAIL TO BE SUPPLIED IN STOCK LENGTHS OF 7'-0" TO 12'-0" VARIABLE. THIS MATERIAL IS TO BE FIELD CUT USING QUALITY EQUIPMENT TO INSURE THAT ALL CUTS ARE SQUARE. WHEN CUTTING MATERIAL SECTIONS, C/S RECOMMENDS USING AN 80-100 TOOTH CARBIDE TIPPED SAW BLADE OR EQUIVALENT, TO MINIMIZE CHIPPING AND MAINTAIN JOINT ALIGNMENT.
4. RADIAL MATERIAL MAY BE SUPPLIED FACTORY FORMED OR IN STRAIGHT LENGTHS FOR FIELD FORMING. CONSULT FACTORY FOR OPTIONS.
5. ALL DIMENSIONS ARE TYPICAL.
6. FOR DRYWALL/PLASTER WALL CONSTRUCTION, IT IS RECOMMENDED FOR FASTENERS TO BE ENGAGED INTO METAL/WOOD STUDS TO MAINTAIN MAXIMUM PULLOUT STRENGTH. IF DURING INSTALLATION YOU ENCOUNTER SPECIAL WALL CONDITIONS THAT DO NOT ALLOW FOR DIRECT ATTACHMENT TO THE STUDS PLEASE CONSULT THE LOCAL AUTHORITY HAVING JURISDICTION.
7. INSTALL OUTSIDE CORNERS FIRST.
8. INSTALL LONGEST RUN OF HANDRAIL FIRST.
9. MATERIAL MUST REACH 65°F MIN. TO 75°F MAX. 24 HOURS PRIOR TO INSTALLATION. THIS IS ESSENTIAL TO MINIMIZE EXPANSION AND CONTRACTION OF MATERIAL.
10. THIS HANDRAIL REQUIRES A MINIMUM OF 2 MOUNTING BRACKETS PER UNIT. THE MINIMUM END CAP-TO-END CAP HANDRAIL LENGTH IS 12 5/8" [320.7mm].
11. FOR OSHPD REQUIREMENTS USE 20 GA. STEEL STUD, 20 GA. INTERMEDIATE STUD, 5/8" GYPSUM WALLBOARD.
12. FOR MORE INFORMATION ON HRWS-6C SEE OUR WEBSITE AT www.c-sgroup.com.

HRWS-6C HANDRAIL

COMPONENTS & WALL FASTENERS



WOOD HANDRAIL
(24W354xxx)

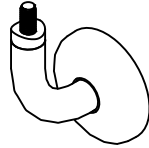

STAINLESS STEEL
MOUNTING BRACKET
(24S061000)

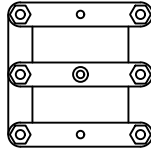

END CAP DRILL JIG
(90F010004)



END CAP DRILL JIG
CENTER ARM FOR
WOOD SPICE
(90H165010)



FASTENER #1
SERRATED
LOCK WASHER
(90H043003)

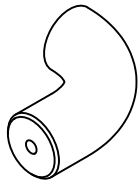

WOOD HANDRAIL ENDCAP
(24W355xxx)



WOOD HANDRAIL
INSIDE/OUTSIDE CORNER
(24W356xxx)

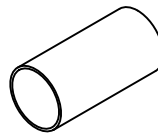

OPTIONAL STAINLESS
STEEL SPLICE
(24S122000)



END CAP SPLINE
(24F194000)

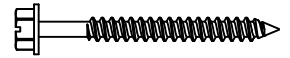

FASTENER #2
#14 X 2 1/2"
HEX WASHER HEAD
SHEET METAL SCREW
(90H437002)

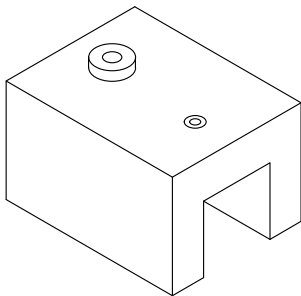

MOUNTING BRACKET JIG
(90H196010)



8mm X 1.25mm PLUG TAP
(90H086010)



O-RING GASKET
(24I109108)



WOOD DOWEL PIN
(24W507037)

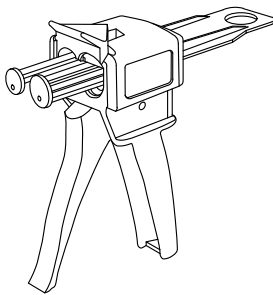

DISPENSER PLUNGER GUN
(90M352001)

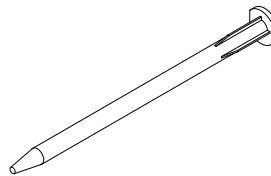

MIXING NOZZLE
(90M022000)

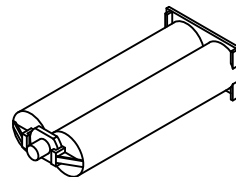

EPOXY
(90M089001)

WALL CONDITION	SPECIFIED FASTENER	DRILL DIAMETERS		C/S PART NUMBER
		WALL	RETAINER	
STEEL STUD/GYPSUM WALL	#10 X 2" PHILLIPS FLAT HEAD SHEET METAL SCREW	1/16"	N/A	90H431002
CONCRETE/CONCRETE BLOCK	1/4" X 2 1/4" HEX HEAD MASONRY	3/16"	N/A	90H027004
WOOD STUD/GYPSUM WALL	#9 X 2 1/4" PHILLIPS WAFFER HEAD DRYWALL SCREW	N/R	N/A	90H421002
20 GA. STEEL STUD/GYPSUM WALL (OSHPD)	1/4-20 X 3" FLAT HEAD BOLT 1/4" TOGGLER WING 3M MOLDABLE FIRE PUTTY	1/2"	N/A	90H282002 90H062004 90M012000

HRWS-6C HANDRAIL

LAYOUT VIEW

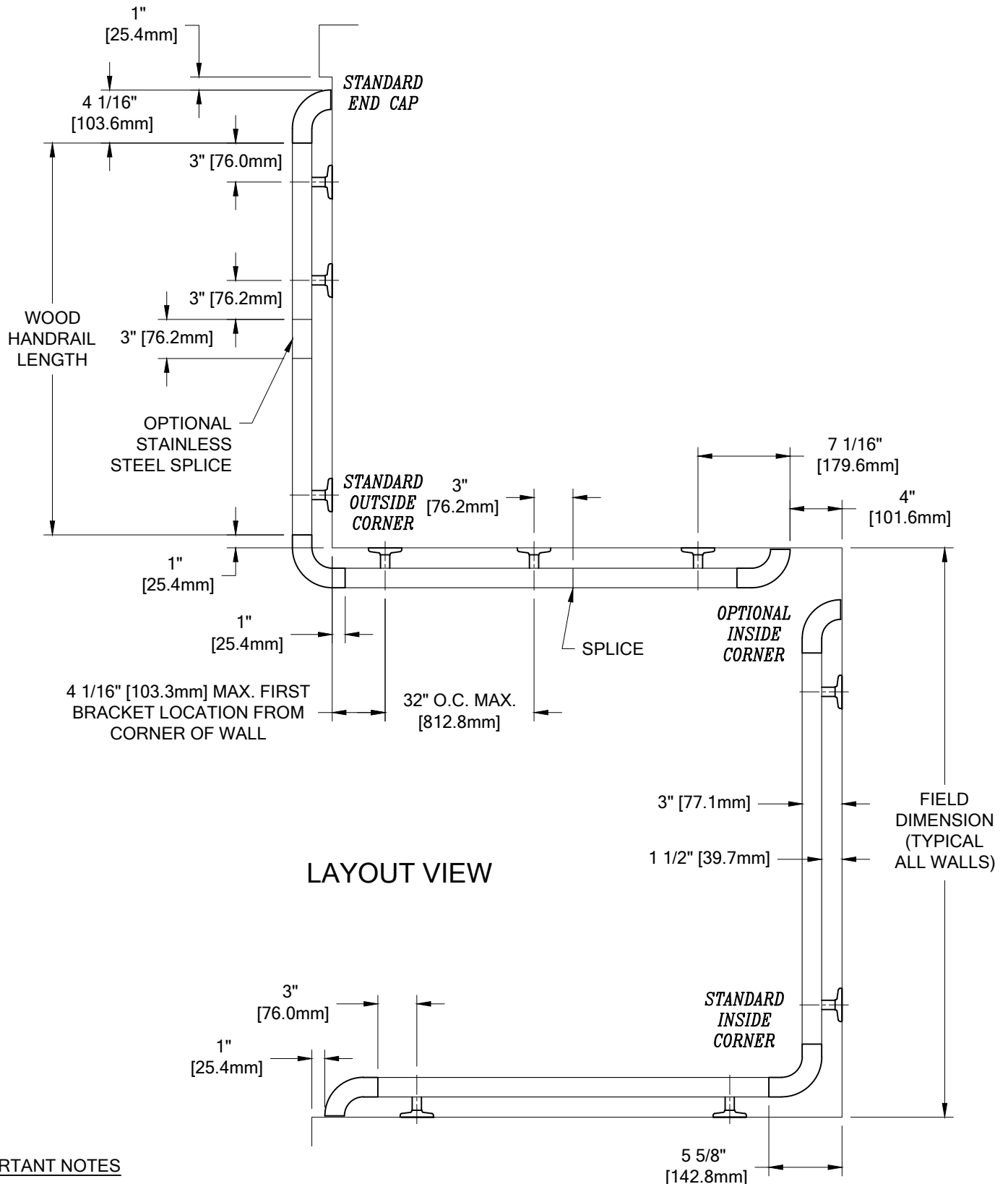

LAYOUT VIEW

IMPORTANT NOTES

1. WOOD HANDRAIL SPLICE SHOULD NOT EXCEED 3" [76.2mm] DISTANCE FROM A BRACKET.
2. TANGENT POINTS ON FACTORY FORMED RADIAL MATERIAL WILL BE MARKED APPROXIMATELY AND SHOULD BE CUT TO SUIT FIELD CONDITIONS.

HRWS-6C HANDRAIL

TYPICAL ASSEMBLY

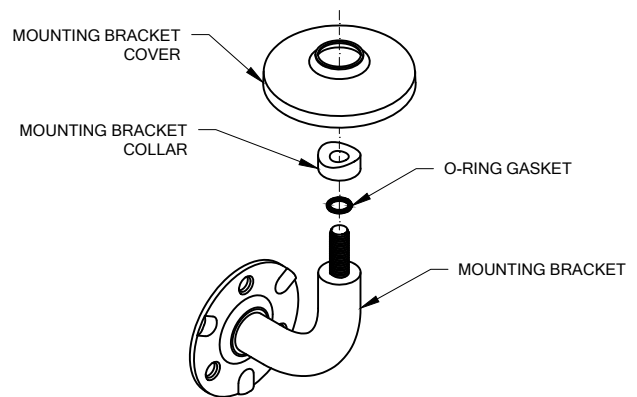
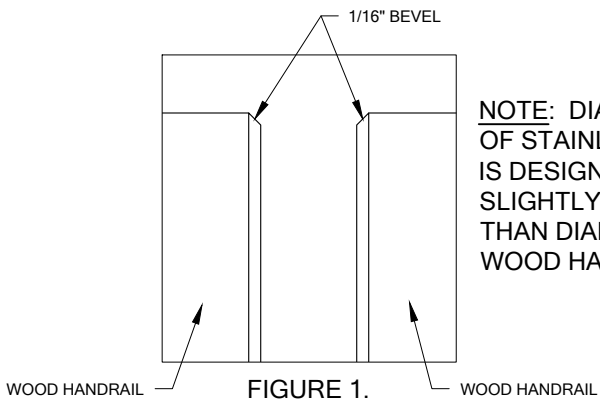
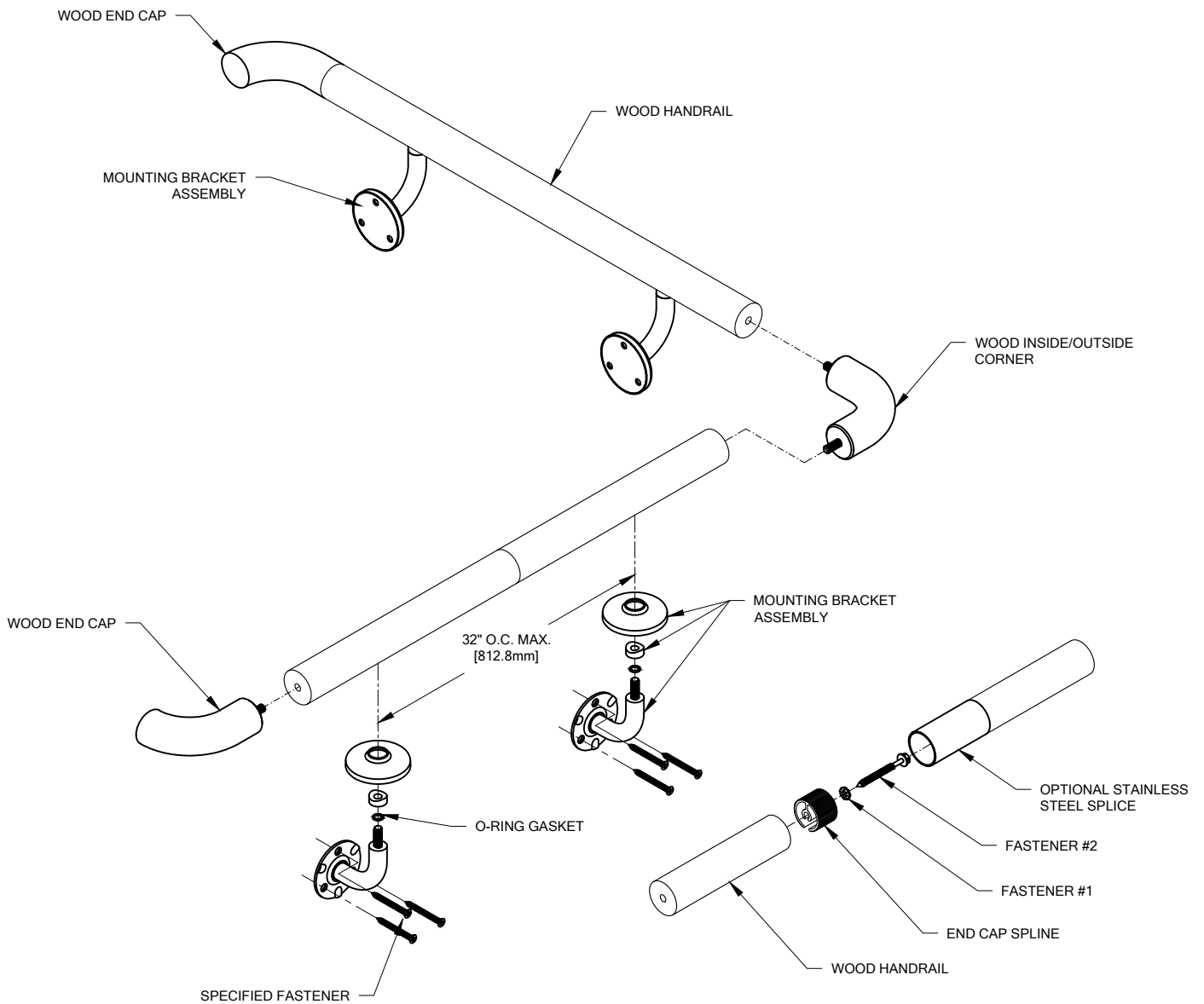

HRWS-6C HANDRAIL

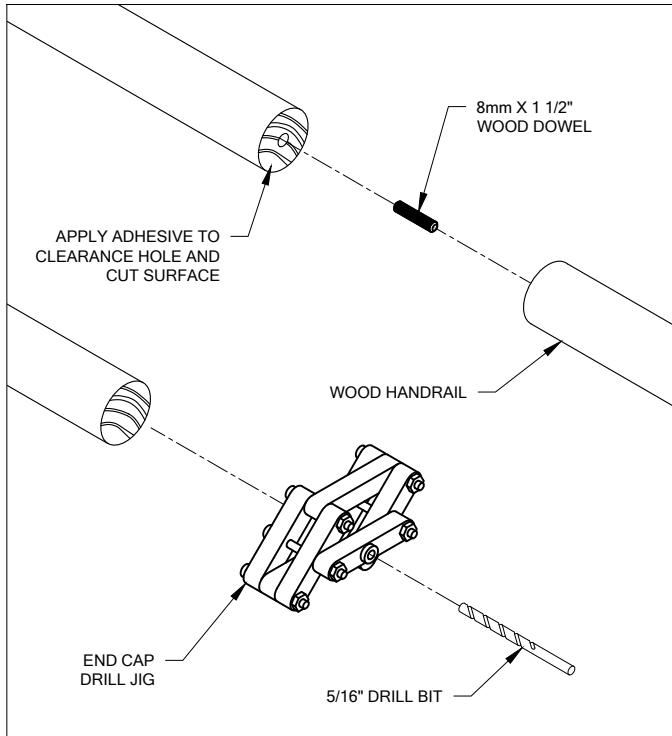

**FIGURE 3.
END CAP/CORNER DRILL
JIG AND WOOD DOWEL SPLICE**

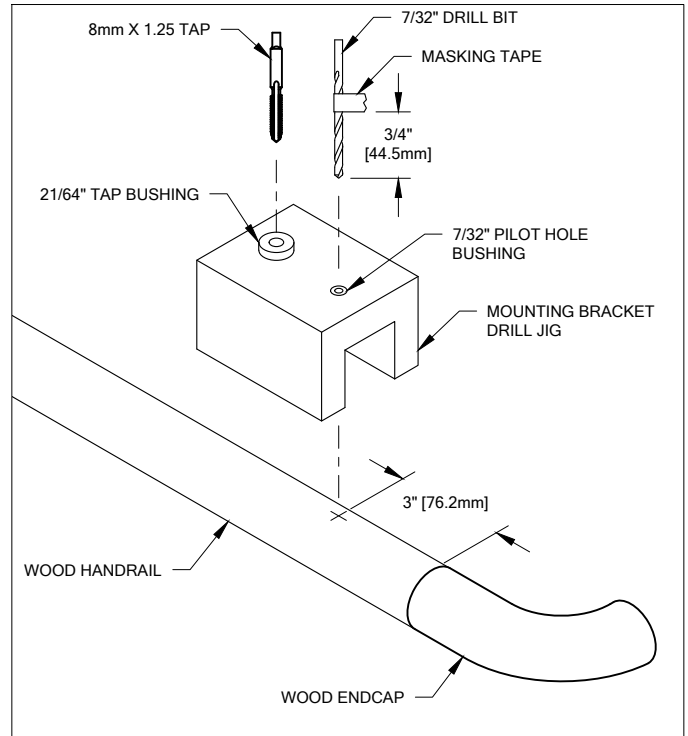

**FIGURE 4.
MOUNTING BRACKET DRILL JIG**

NOTE: INSTALLATION OF LINEAL OR RADIAL HRWS-6CW HANDRAIL SHOULD BE DONE IN ACCORDANCE WITH THE FOLLOWING INSTRUCTIONS.

1. USING "LOCAL CODE" REQUIREMENTS, ESTABLISH HANDRAIL HEIGHT ABOVE FINISH FLOOR. DEDUCT 3 9/16" [90.5mm] AND SNAP A CHALK LINE AT THAT HEIGHT. THIS MARKS THE LOCATION OF THE HOLE FOR THE MOUNTING BRACKET FASTENERS. REFER TO SECTIONAL VIEW.
2. CUT THE WOOD HANDRAIL TO LENGTH USING THE REQUIRED DEDUCTIONS (REFERENCE LAYOUT VIEW). BEVEL THE HANDRAIL EDGES SLIGHTLY WITH 150 GRIT SANDPAPER. TOUCH UP SANDED EDGES WITH SUPPLIED STAIN MARKER. (SEE FIGURE 1)

NOTE: IT IS RECOMMENDED THAT WOOD HANDRAIL BE CUT WITH AN 80-100 TOOTH CARBIDE TIPPED SAW BLADE OR EQUIVALENT.

3. TO ENSURE PROPER ALIGNMENT OF HANDRAIL TO END CAP, USE THE END CAP DRILL JIG TO DRILL A HOLE FOR DOWEL PIN IN EACH END OF THE HANDRAIL. (SEE FIGURE 3)
 - LOCATE END CAP DRILL JIG OVER END OF WOOD HANDRAIL. POSITION END OF HANDRAIL TIGHT AGAINST BOTTOM OF DRILL JIG'S CENTER BAR.
 - CLOSE THE DRILL JIG TIGHT AGAINST THE OUTSIDE EDGE OF THE HANDRAIL.
 - DRILL A 5/16" PILOT HOLE, 7/8" DEEP, IN EACH END OF THE HANDRAIL.
4. INSTALL HANDRAIL SPLICE IF REQUIRED (SEE FIGURE 3). FOR OPTIONAL STAINLESS STEEL SPLICE SEE PAGE 6 (FIGURES 5 & 6).
5. ATTACH MOUNTING BRACKET ASSEMBLIES (A FLAT SURFACE IS REQUIRED):
 - USING FLAT SURFACE ORIENT ANY IMPERFECTIONS IN HANDRAIL ON DOWNWARD SIDE OF ASSEMBLY.
 - DRILL PILOT HOLES IN BOTTOM SURFACE OF HANDRAIL AS PER MOUNTING BRACKET DRILL JIG INSTRUCTIONS ON PAGE 6 (SEE FIGURE 4). MOUNTING BRACKETS ARE TO BE LOCATED AT A MAXIMUM OF 32" [812.8mm] O.C. AND MUST BE 3" [76.2mm] FROM END OF HANDRAIL AND 3" [76.2mm] FROM ONE END OF SPLICE. **CAUTION: BE SURE THE HANDRAIL DOES NOT ROTATE WHEN DRILLING PILOT HOLE.**
 - BEFORE USING THE 21/64" BUSHING (TAP END OF MOUNTING BRACKET JIG) ON THE HANDRAIL'S FIRST PILOT HOLE, INSERT A 7/32" DRILL BIT THROUGH MOUNTING BRACKET DRILL JIG AND INTO PILOT HOLE. THIS STEP WILL HELP ENSURE HANDRAIL DOES NOT ROTATE WHEN DRILLING AND TAPPING FOR ADDITIONAL MOUNTING BRACKETS. A SECOND MOUNTING BRACKET DRILL JIG HAS BEEN PROVIDED TO DRILL AND TAP FOR ADDITIONAL MOUNTING BRACKETS.
 - USING THE 21/64" BUSHING (TAP END OF MOUNTING BRACKET JIG), THREAD PILOT HOLE USING AN 8mm X 1.25 TAP (PLUG CHAMFER TYPE RECOMMENDED).
 - ATTACH MOUNTING BRACKETS. **CAUTION: OVER-TORQUEING MAY CAUSE DAMAGE TO WOODEN THREADS.**
6. USE ASSEMBLED HANDRAIL AS A TEMPLATE TO DRILL CLEARANCE HOLES IN WALL SURFACE FOR MOUNTING HARDWARE BY LINING UP UPPER EDGE OF MOUNTING BRACKET WITH CHALK LINE. REFERENCE CHART ON PAGE 2 FOR CORRECT DRILL DIAMETERS.
7. INSTALL HANDRAIL USING APPROPRIATE FASTENERS. USE A LEVEL TO ENSURE HANDRAIL IS LEVEL.

NOTE: WHEN FIELD FORMING RADIUS HANDRAIL, BE SURE TO APPLY NEEDED PRESSURE FROM BRACKET TO BRACKET.

8. ATTACH WOOD INSIDE/OUTSIDE CORNERS BEFORE ATTACHING NEXT SECTION OF HANDRAIL BY SLIDING THE DOWEL INTO THE PILOT HOLE IN THE HANDRAIL. BEFORE APPLYING WOOD GLUE, DRY FIT COMPONENTS TOGETHER TO DOUBLE CHECK FIT. APPLY WOOD GLUE INTO THE HOLE AND HANDRAIL CUT SURFACE PRIOR TO CORNER INSERTION. TITEBOND WOOD GLUE IS RECOMMENDED FOR THIS APPLICATION. WIPE OFF ANY EXCESS GLUE.
9. ATTACH WOOD END CAPS TO HANDRAIL IN SAME MANNER AS INSIDE/OUTSIDE CORNERS.

HRWS-6C HANDRAIL

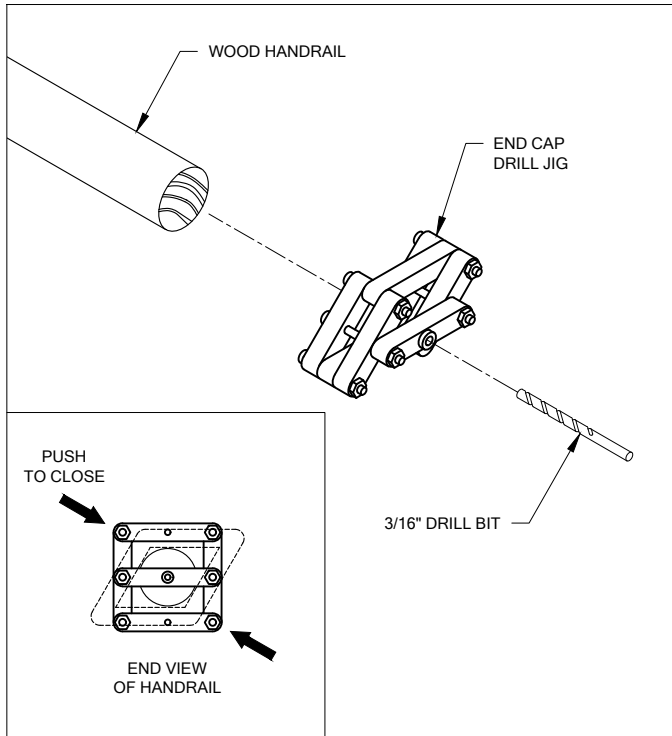

**FIGURE 5.
OPTIONAL STAINLESS
STEEL SPLICE DRILL JIG**

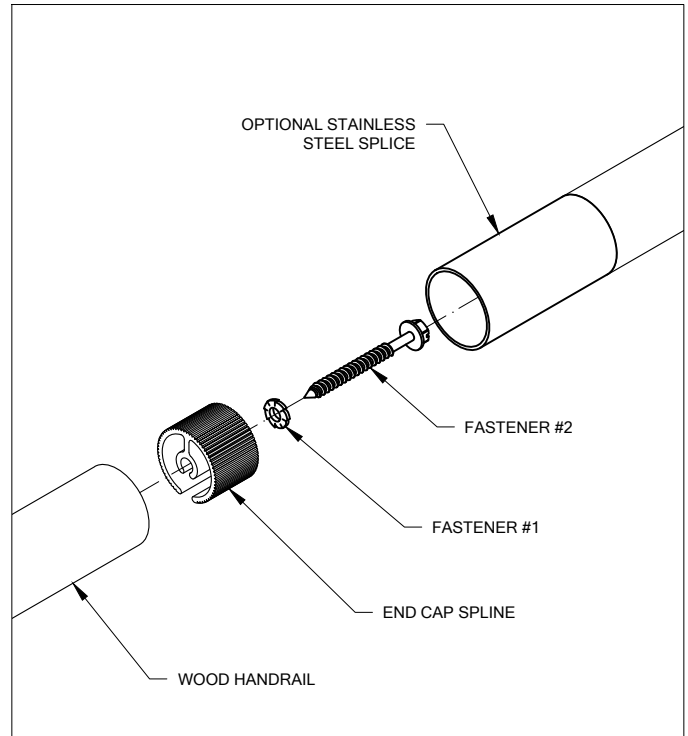

**FIGURE 6.
OPTIONAL STAINLESS
STEEL SPLICE ASSEMBLY**

MOUNTING BRACKET DRILL JIG INSTRUCTIONS

1. PLACE HANDRAIL ON FLAT WORKING SURFACE AND ROTATE UNTIL BOTTOM OF HANDRAIL IS FACING UPWARD.
2. POSITION DRILL JIG OVER WOOD HANDRAIL. THE DRILL JIG'S FEET MUST SIT FLAT ON LEVEL WORKING SURFACE. LOCATE CENTER OF 7/32" PILOT DRILL HOLE OVER CORRESPONDING LOCATION FOR MOUNTING BRACKET ASSEMBLY. NOTE: DIMENSION FROM CENTER OF EITHER HOLE TO END OF JIG IS 3" [76.2mm].
3. DRILL A 7/32" PILOT HOLE (ONLY 1" DEEP) IN BOTTOM OF HANDRAIL. TO HELP ENSURE PROPER DEPTH INTO BOTTOM OF HANDRAIL APPLY A PIECE OF MASKING TAPE AS A MARKER 1 3/4" [44.5mm] FROM THE END OF DRILL BIT.
4. POSITION TAP END OF MOUNTING BRACKET JIG OVER PREVIOUSLY DRILLED 7/32" PILOT HOLE. USE 21/64" DRILL BUSHING TO CORRECTLY THREAD PILOT HOLE WITH 8mm X 1.25 TAP (PLUG CHAMFER TYPE RECOMMENDED).

OPTIONAL STAINLESS STEEL SPLICE

1. TO PROTECT FINISHED SURFACES FROM ADHESIVE DURING ASSEMBLY APPLY MASKING TAPE TO END OF HANDRAIL'S FINISHED WOOD SURFACE AND EXTERIOR SURFACE OF SPLICE.
2. CLEAN OUTER SURFACE OF ALUMINUM SPLINE WITH ISOPROPYL (RUBBING) ALCOHOL. ATTACH SPLINE TO THE END OF THE HANDRAIL USING THE #14 X 2 1/2" HEX WASHER HEAD SHEET METAL SCREW AND SERRATED LOCK WASHER. DRY FIT HANDRAIL TO SPLICE AND CHECK FOR A SEAMLESS TRANSITION BETWEEN WOOD AND METAL COMPONENTS.
3. ONCE TESTED, FILL THE PILOT HOLE WITH ADHESIVE (REFERENCE CAULKING GUN CONVERSION KIT FIGURES 7 & 8) AND PERMANENTLY ATTACH ALUMINUM SPLINE. CAUTION: SERRATED LOCK WASHER MUST BE SECURELY TIGHTENED AND EMBEDDED INTO ALUMINUM SPLINE TO PREVENT ATTACHED SPLICE FROM ROTATING.
4. USING 100 GRIT SANDPAPER, SAND THE INTERIOR SURFACE OF THE SPLICE. CLEAN THE INTERIOR SURFACE OF THE SPLICE WITH ISOPROPYL (RUBBING) ALCOHOL.
5. THE ADHESIVE ONLY ALLOWS FOR 8 TO 12 MINUTES OF WORKING TIME. INSTALL SPLICE OVER ALUMINUM SPLINE. FOR PROPER SEAM, STAINLESS STEEL SPLICE MUST BE TIGHTLY FITTED TO THE HANDRAIL. PARTS CAN BE HANDLED IN 1 1/2 HOURS AND WILL BE FULLY CURED AFTER 24 HOURS.

HRWS-6C HANDRAIL

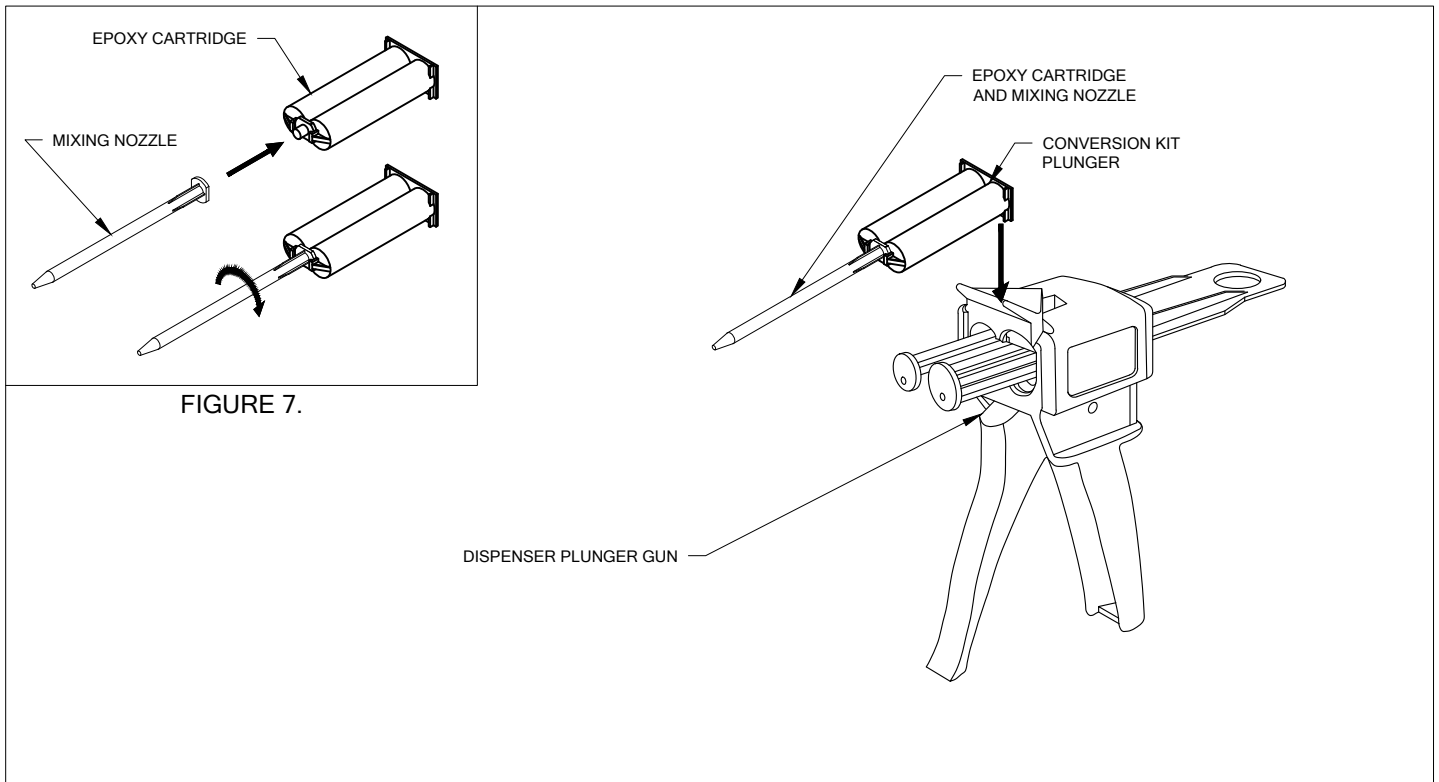

FIGURE 7.

FIGURE 8.

DISPENSER PLUNGER GUN

EPOXY CARTRIDGE AND MIXING NOZZLE. REFER TO FIGURE 6.

1. REMOVE CAP AND GASKET FROM THE END OF EPOXY CARTRIDGE BY TWISTING 90°.
2. INSTALL MIXING NOZZLE ON THE FRONT OF EPOXY CARTRIDGE AND LOCK IN PLACE BY TWISTING 90°.
3. INSERT EPOXY CARTRIDGE AND MIXING NOZZLE INTO THE DISPENSING PLUNGER GLUE GUN BY SLIDING IT INTO THE FRONT AND CLOSING THE LOCKING TAB.

08/29/2023