

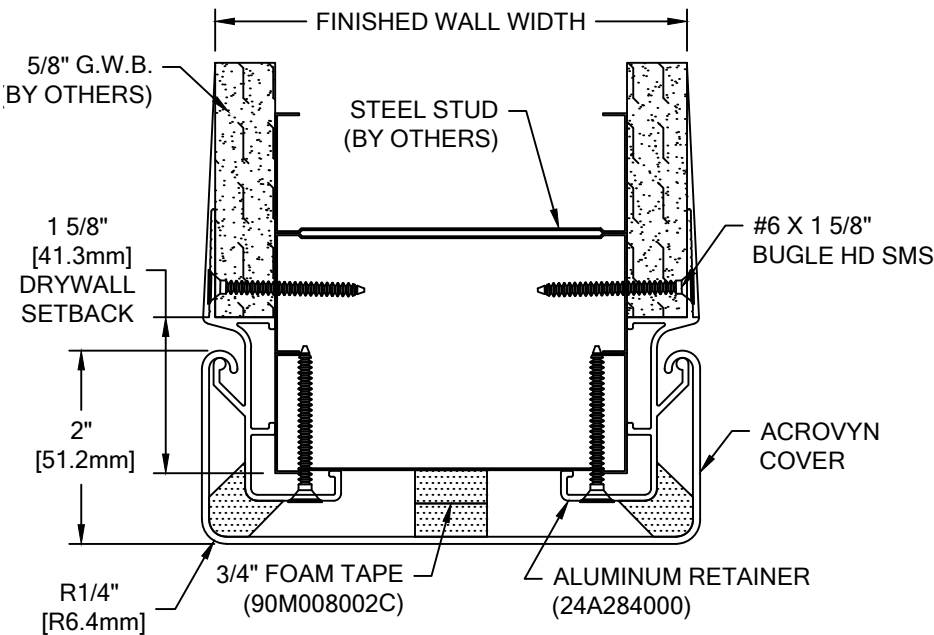

COLOR: CHANNEL GUARD: _____ COLOR TO BE SELECTED FROM ONE OF CS STANDARD COLORS.	UNITS	CEILING	RET.	COVER	BASE	WALL
	REQ'D	HEIGHT	LENGTH	LENGTH	HEIGHT	WIDTH
NOTES: 1. UNITS TO BE FURNISHED IN LENGTHS TO ACCOMMODATE THE SPECIFIED CEILING HEIGHT, WITH 2" ADDED FOR FIELD VARIATIONS. WHERE POSSIBLE, THIS 2" SHOULD EXTEND INTO THE CEILING. 2. A MINIMUM 24 GA. CHANNEL STUD MUST BE SECURELY ANCHORED TOP AND BOTTOM TO INSURE POSITIVE ATTACHMENT OF ALUMINUM RETAINERS. IF TRUSS STUDS ARE USED, CHANNEL STUDS MUST BE USED AT CORNER. 3. MAXIMUM LENGTH FOR ACROVYN COVERS IS 10'-0". LENGTHS GREATER THAN THIS WILL BE MADE IN 2 PIECES. 4. FSC-25N CHANNEL GUARDS HAVE A STANDARD MINIMUM WIDTH OF 3 1/8" AND MAXIMUM WIDTH OF 12". ANYTHING GREATER THAN 12" REQUIRES REVIEW AND CUSTOM PRICING.						

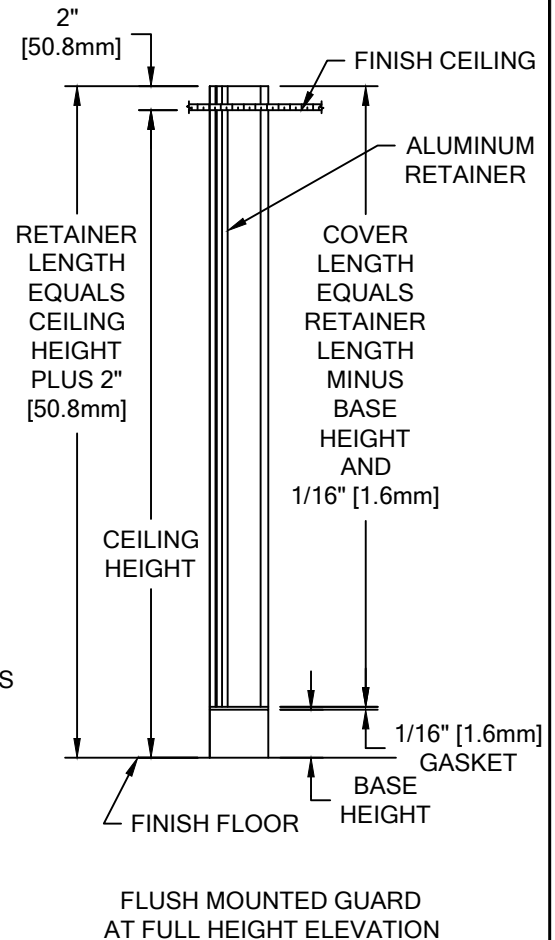

FSC-25N ACROVYN 4000

WALL CONDITION	SPECIFIED FASTENER	DRILL DIAMETERS		CS PART NUMBER
		WALL	RETAINER	
SINGLE LAYER DRYWALL	#6 X 1-5/8" BUGLE HEAD SHEET METAL SCREW	N/A	N/A	90H079002
DOUBLE LAYER DRYWALL	#8 X 3" BUGLE HEAD SHEET METAL SCREW	N/A	N/A	90H857002

 Hughesville, PA 800.233.8493 570.546.5941 Mississauga, ON 888.895.8955 905.274.3611 www.c-sgroup.com © Copyright 2017 Construction Specialties, Inc.	PROJECT:	REVISION:
	JOB NO.:	F&F:
	CUSTOMER:	
	REP:	DATE:
	DRAWN BY:	SHEET NO: