

COLOR: _____
 DOOR FRAME PROTECTOR: _____
 COLOR TO BE SELECTED FROM ONE OF C/S STANDARD COLORS.

NOTES:

1. ACROVYN DOOR FRAME PROTECTORS MAY GAP AWAY FROM FRAME 1/32" TO 1/16" AND HAVE A TOLERANCE OF +1/16" / -0".
2. PLEASE ADVISE IF OPTIONAL HEAT STAMP IS REQUIRED ON DOOR FRAME PROTECTOR.
3. OPTIONAL FIRE RATING HEAT STAMP LOCATED ON FACE OF DOOR FRAME PROTECTOR.
4. DOOR FRAME DIMENSIONS TYPICALLY VARY FROM ONE ANOTHER THROUGHOUT THE FACILITY.
5. THE TERMS "LEFT LATCH" AND "RIGHT HINGE" ARE USED TO EXPLAIN ORIENTATION AND DETERMINE SIDE OF DOOR FRAME REQUIRED. EXAMPLE: DOOR LATCH SHOULD BE ON LEFT HAND SIDE, DOOR HINGE SHOULD BE ON RIGHT HAND SIDE. PLEASE ADVISE

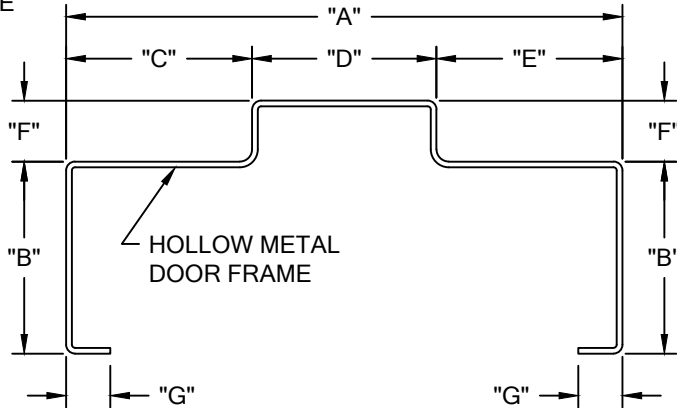

DOOR FRAME DIMENSIONS

A: _____
 B: _____
 C: _____
 D: _____
 E: _____
 F: _____
 G: _____
 MOLD ID: _____
 AREA: _____

**B SERIES DFPN
 ACROVYN 4000**

MATERIAL	DFPN PIECES REQ'D	LENGTH/ HEIGHT
HEADER PROTECTION		
JAMB PROTECTION LEFT/LATCH SIDE		
JAMB PROTECTION RIGHT/HINGE SIDE		
OPTIONAL HEAT STAMP REQUIRED (YES / NO)		
SELECT HINGE SIDE PER TEMPLATE BELOW: "C" OR "E"		

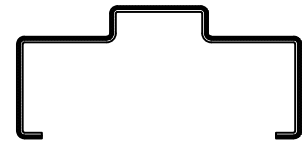

B-1 DFPN
EXTENDED FRAME

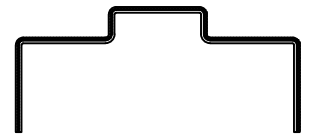

B-2 DFPN
FLUSH FRAME

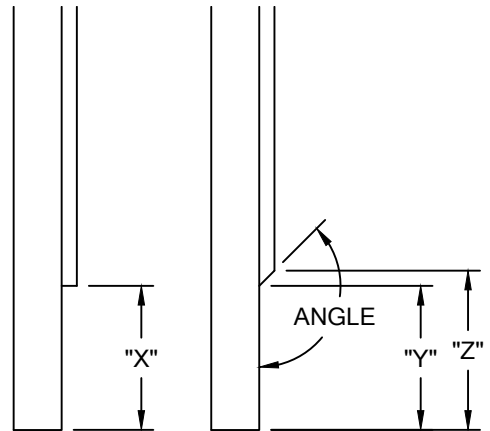

OPTIONAL HOSPITAL STOP

X: _____
 Y: _____
 Z: _____
 ANGLE: _____

CONDITION	SPECIFIED FASTENER	QUANTITY	C/S PART NUMBER
WOOD & METAL DOORS	FASTBOND 30 ADHESIVE	5 GALLON 1 GALLON 1 QUART	90M016001 90M014001 90M015001
WOOD & METAL DOORS	DOUBLE SIDED TAPE	3/4" WIDE	90M181002

 <p>Construction Specialties™ 6696 Route 405 Highway, Muncy PA 17756 (800) 233-8493 • Fax (570) 546-4692 • www.c-sgroup.com</p>	PROJECT:	REVISION:
	JOB NO.:	F&F:
	CUSTOMER:	
	REP:	DATE:
	DRAWN BY:	SHEET NO: