

PEDITRED SA WITH RECESSED LEVEL BASE FRAME AND RADIUS EDGE FRAME

INSERT STYLE: PEDITRED SA

INSERT COLOR: PLEASE ADVISE

CATALOG NUMBER: G4

PART NUMBER:

NO.	REVISION	DATE	BY
NO.	F&F RELEASE	DATE	BY

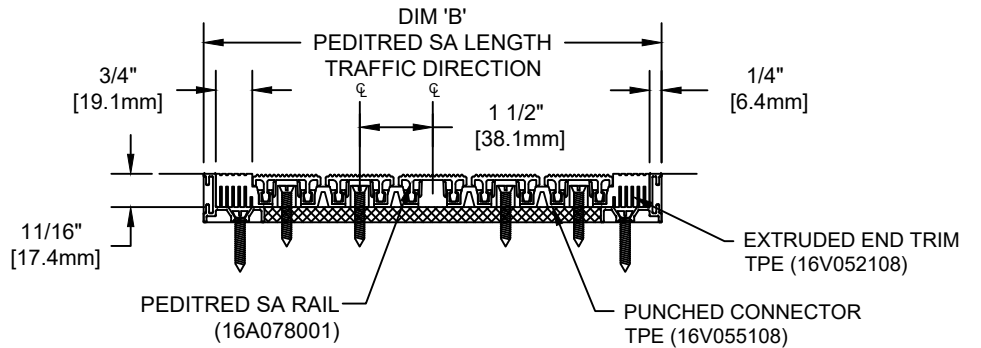
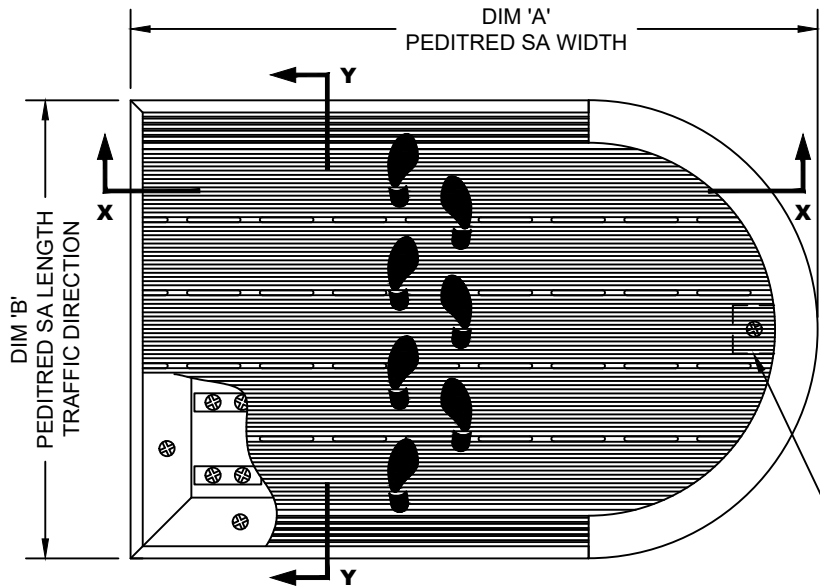

ALUMINUM TAB WELDED TO BOTTOM FLANGE OF RADIUS FRAME FOR MASONRY LAG FASTENER (90H066004) 24" (609.6mm) O.C.

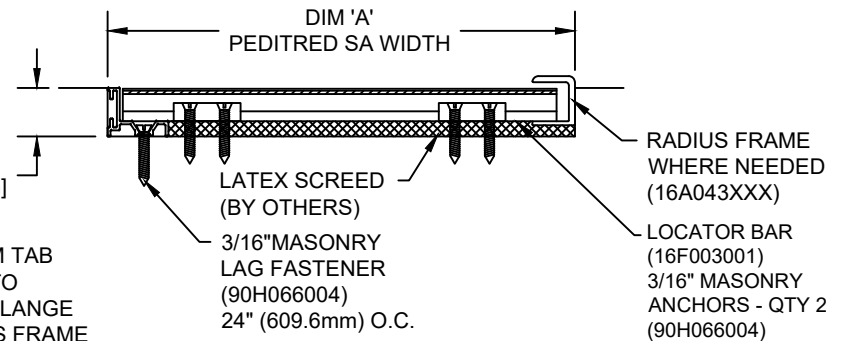

NOTES:

*ALL SURFACES IN CONTACT WITH MASONRY ARE TO RECEIVE A COAT OF ZINC CHROMATE PRIMER

*MAX. SINGLE GRID SIZE NOT TO EXCEED 12'-0" (3.66M) IN WIDTH (DIM "A") OR 3'-0" (.91M) IN LENGTH (DIM "B").

*PLEASE VERIFY TRAFFIC DIRECTION

*ADDITIONAL SPECIFICATIONS ARE CONTAINED IN THE LATEST C/S CATALOG OR AT C-SGROUP.COM AND ARE CONSIDERED PART OF THIS TRANSMITTAL.

*PEDITRED SA SHALL BE ABLE TO SUPPORT A 1000 LB. ROLLING LOAD.

CS Construction Specialties
6696 Route 405 Highway, Muncy PA 17756
(800) 233-8493 • Fax (570) 546-4692 • www.c-sgroup.com

PLEASE VERIFY ALL	QTY	MARK #	LOCATION	MODEL	DIM 'A' WIDTH	DIM 'B' LENGTH	FINISH	NOTES

PROJECT:		
LOCATION:		
CONTRACTOR:		
AGENT:		SHT:
DRG. BY:	DATE:	JOB NO.: