

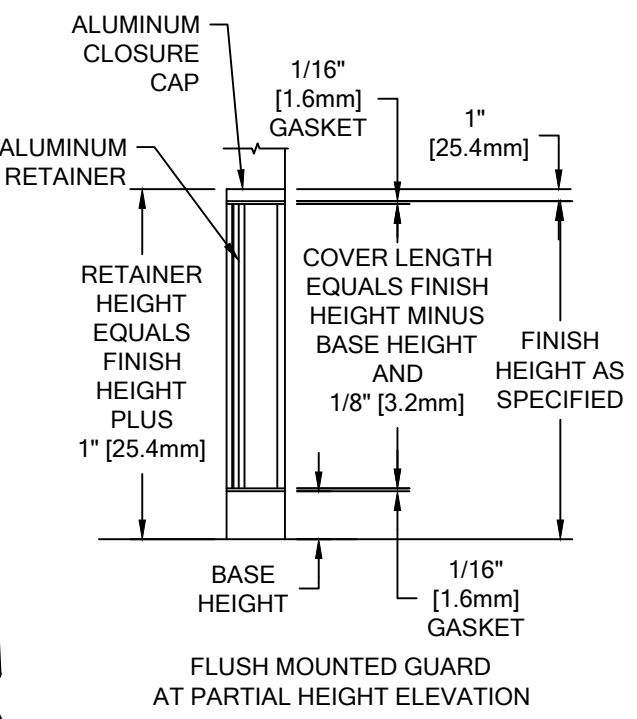

| | | | | | | |
|---|--------------|----------------|---------------|---------------|---------------|--------------|
| COLOR: CHANNEL GUARD: _____ COLOR TO BE SELECTED FROM ONE OF CS STANDARD COLORS. | UNITS | CEILING | RET. | COVER | BASE | WALL |
| | REQ'D | HEIGHT | LENGTH | LENGTH | HEIGHT | WIDTH |
| NOTES: 1. A MINIMUM 24 GA. CHANNEL STUD MUST BE SECURELY ANCHORED TOP AND BOTTOM TO INSURE POSITIVE ATTACHMENT OF ALUMINUM RETAINERS. IF TRUSS STUDS ARE USED, CHANNEL STUDS MUST BE USED AT CORNER. 2. MAXIMUM LENGTH FOR ACROVYN COVERS IS 9'-6". LENGTHS GREATER THAN THIS WILL BE MADE IN 2 PIECES. 3. FSC-25N CHANNEL GUARDS HAVE A STANDARD MINIMUM WIDTH OF 3 1/8" AND MAXIMUM WIDTH OF 12". ANYTHING GREATER THAN 12" REQUIRES REVIEW AND CUSTOM PRICING. | | | | | | |
| | | | | | | |
| | | | | | | |

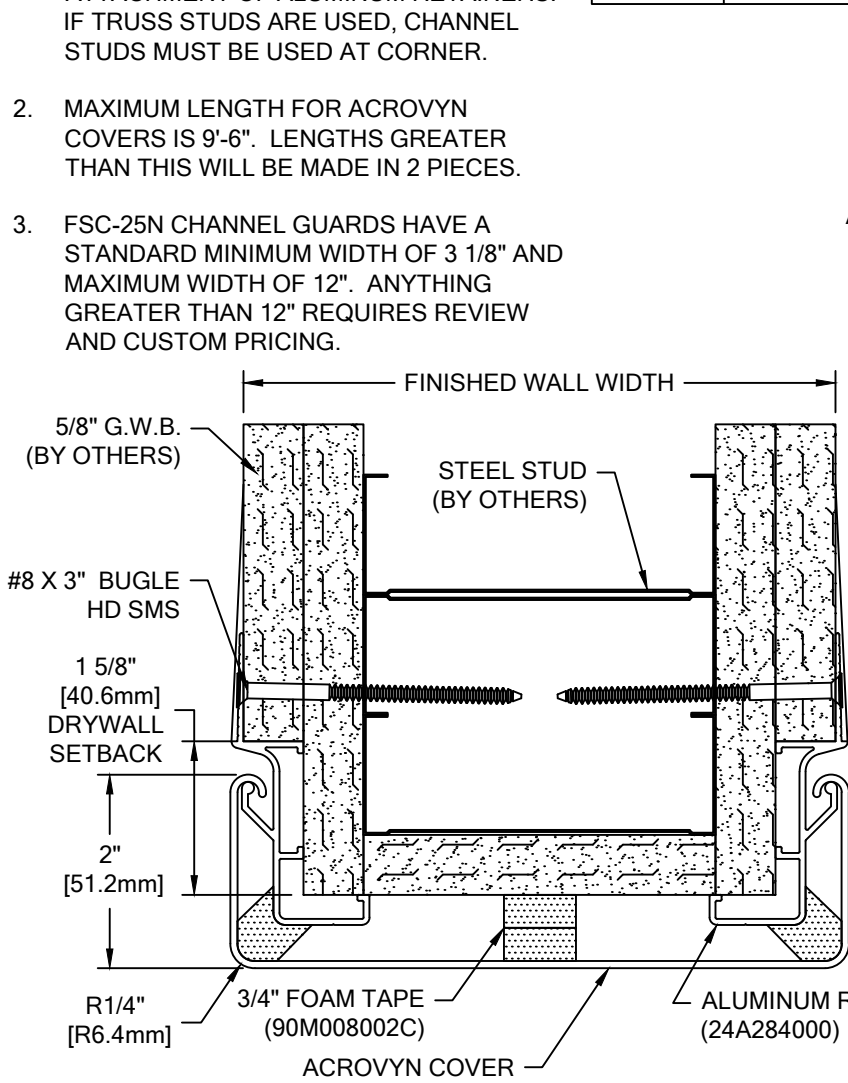

FSC-25N ACROVYN 4000

| WALL CONDITION | SPECIFIED FASTENER | DRILL DIAMETERS | | CS PART NUMBER |
|----------------------|--|-----------------|----------|----------------|
| | | WALL | RETAINER | |
| SINGLE LAYER DRYWALL | #6 X 1-5/8" BUGLE HEAD SHEET METAL SCREW | N/A | N/A | 90H079002 |
| DOUBLE LAYER DRYWALL | #8 X 3" BUGLE HEAD SHEET METAL SCREW | N/A | N/A | 90H857002 |

| | | |
|---|------------------|------------------|
|  Hughesville, PA 800.233.8493 570.546.5941 Mississauga, ON 888.895.8955 905.274.3611 www.c-sgroup.com © Copyright 2016 Construction Specialties, Inc. | PROJECT: | REVISION: |
| | JOB NO.: | F&F: |
| | CUSTOMER: | |
| | REP: | DATE: |
| | DRAWN BY: | SHEET NO: |