

SJPM Series

TECHNICAL DATA:

Aluminum

- Extrusion – CS uses multiple alloys & tempers which are established to be the most appropriate for the given use of individual parts. Will be one of the following: (6063-T5, T6, T52) (6061-T5, T6, T51) (6105-T5, T6) (6005-T5) (6005A-T5, T61), ASTM B221
- Sheet – 6061-T6, 3003-H14, 5005-H34, ASTM B209

Turnbar

- Material – C1075 Blue Temper Spring Steel
- Hardness - RC 44-47
- Finish - "A" Coating (Corrosion Protection)

Standard Loading

- 500 lbs.

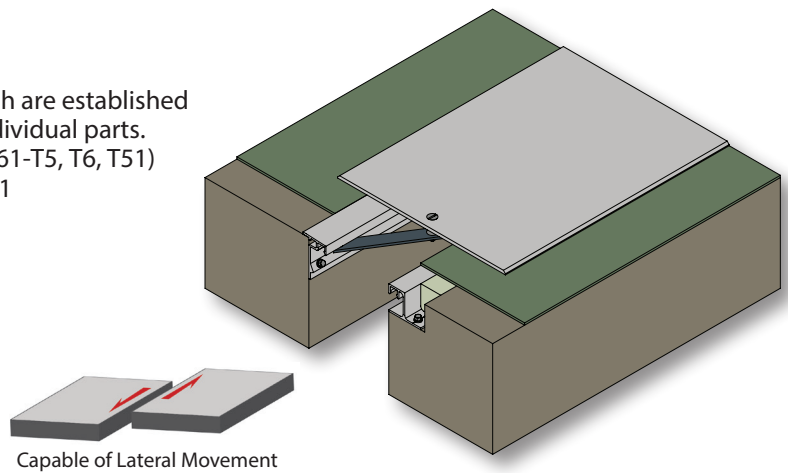

MODEL	JOINT WIDTH	MINIMUM OPENING	MAXIMUM OPENING	EXPOSED SURFACE	BLOCKOUT WIDTH	BLOCKOUT HEIGHT
SJPM-100	1.00" (25mm)	0.50" (13mm)	2.00" (51mm)	4.50" (114mm)	3.75" (95mm)	1.50" (38mm)
SJPM-200	2.00" (51mm)	1.00" (25mm)	4.00" (102mm)	4.50" (114mm)	2.75" (70mm)	1.50" (38mm)
SJPM-300	3.00" (76mm)	1.50" (38mm)	4.50" (114mm)	6.50" (165mm)	2.75" (70mm)	1.50" (38mm)
SJPM-400	4.00" (102mm)	1.75" (44mm)	8.00" (203mm)	7.50" (191mm)	2.25" (57mm)	1.50" (38mm)
SJPM-500	5.00" (127mm)	1.75" (44mm)	8.50" (216mm)	10.50" (267mm)	2.25" (57mm)	1.50" (38mm)
SJPM-600	6.00" (152mm)	1.75" (44mm)	12.00" (305mm)	11.88" (302mm)	2.25" (57mm)	1.50" (38mm)
SJPM-700	7.00" (178mm)	1.75" (44mm)	13.50" (343mm)	13.50" (343mm)	2.25" (57mm)	1.50" (38mm)
SJPM-800	8.00" (203mm)	1.75" (44mm)	13.50" (343mm)	15.00" (381mm)	2.25" (57mm)	1.50" (38mm)
SJPM-900	9.00" (229mm)	1.75" (44mm)	16.75" (425mm)	16.50" (419mm)	2.25" (57mm)	1.50" (38mm)
SJPM-1000	10.00" (254mm)	1.75" (44mm)	17.75" (451mm)	18.00" (457mm)	2.25" (57mm)	1.50" (38mm)
SJPM-1100	11.00" (279mm)	1.75" (44mm)	17.75" (451mm)	19.50" (495mm)	2.25" (57mm)	1.50" (38mm)
SJPM-1200	12.00" (305mm)	1.75" (44mm)	21.75" (552mm)	21.00" (533mm)	2.25" (57mm)	1.50" (38mm)
SJPM-1300	13.00" (330mm)	1.75" (44mm)	22.00" (559mm)	22.50" (572mm)	2.25" (57mm)	1.50" (38mm)
SJPM-1400	14.00" (356mm)	1.75" (44mm)	24.50" (622mm)	24.00" (610mm)	2.25" (57mm)	1.50" (38mm)
SJPM-1500	15.00" (381mm)	1.75" (44mm)	25.25" (641mm)	25.50" (648mm)	2.25" (57mm)	1.50" (38mm)
SJPM-1600	16.00" (406mm)	1.75" (44mm)	25.25" (641mm)	27.00" (686mm)	2.25" (57mm)	1.50" (38mm)

Contact factory for larger sizes.

