

XLP-2G & XLPC-2G

TECHNICAL DATA:

Aluminum

- Extrusion – CS uses multiple alloys & tempers which are established to be the most appropriate for the given use of individual parts. Will be one of the following: (6063-T5, T6, T52) (6061-T5, T6, T51) (6105-T5, T6) (6005-T5) (6005A-T5, T61), ASTM B221

Aluminum Pivot Hinges

- Three Pivot Hinges with Stainless Steel pins

Vapor Barrier

- Material: 7-Ply Polyethylene, ASTM-E-1745-11
- Color: Black
- 3" Tensile Strength: 275 lbs., ASTM-D-882
- Puncture Strength: 79 lbs., ASTM-D-4833
- PPT Resistance: 62 lbs., ASTM-D-2582

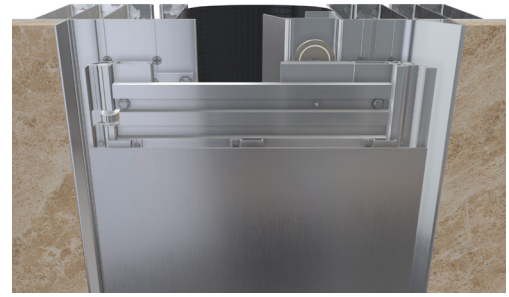

Capable of Lateral Movement

MODEL	JOINT WIDTH	MINIMUM OPENING	MAXIMUM OPENING	EXPOSED SURFACE	BLOCKOUT WIDTH "A"	BLOCKOUT HEIGHT	BLOCKOUT WIDTH "B"
XLP2G-800	8.00" (203mm)	4.00" (102mm)	16.00" (406mm)	18.50" (470mm)	5.25" (133mm)	2.00" (51mm)	5.25" (133mm)
XLP2G-900	9.00" (229mm)	4.00" (102mm)	18.00" (457mm)	19.50" (495mm)	5.25" (133mm)	2.00" (51mm)	5.25" (133mm)
XLP2G-1000	10.00" (254mm)	4.00" (102mm)	20.00" (508mm)	20.50" (521mm)	5.25" (133mm)	2.00" (51mm)	5.25" (133mm)
XLP2G-1100	11.00" (279mm)	4.00" (102mm)	22.00" (559mm)	21.50" (546mm)	5.25" (133mm)	2.00" (51mm)	5.25" (133mm)
XLP2G-1200	12.00" (305mm)	4.00" (102mm)	24.00" (610mm)	22.50" (572mm)	5.25" (133mm)	2.00" (51mm)	5.25" (133mm)
XLP2G-1300	13.00" (330mm)	4.00" (102mm)	26.00" (660mm)	23.50" (597mm)	5.25" (133mm)	2.00" (51mm)	5.25" (133mm)
XLP2G-1400	14.00" (356mm)	4.00" (102mm)	28.00" (711mm)	24.50" (622mm)	5.25" (133mm)	2.00" (51mm)	5.25" (133mm)
XLP2G-1500	15.00" (381mm)	4.00" (102mm)	30.00" (762mm)	25.50" (648mm)	5.25" (133mm)	2.00" (51mm)	5.25" (133mm)
XLP2G-1600	16.00" (406mm)	4.00" (102mm)	32.00" (813mm)	26.50" (673mm)	5.25" (133mm)	2.00" (51mm)	5.25" (133mm)
XLP2G-1700	17.00" (432mm)	4.00" (102mm)	34.00" (864mm)	27.50" (699mm)	5.25" (133mm)	2.00" (51mm)	5.25" (133mm)
XLP2G-1800	18.00" (457mm)	4.00" (102mm)	36.00" (914mm)	28.50" (724mm)	5.25" (133mm)	2.00" (51mm)	5.25" (133mm)
XLP2G-1900	19.00" (483mm)	4.00" (102mm)	38.00" (965mm)	29.50" (749mm)	5.25" (133mm)	2.00" (51mm)	5.25" (133mm)
XLP2G-2000	20.00" (508mm)	4.00" (102mm)	40.00" (1,016mm)	30.50" (775mm)	5.25" (133mm)	2.00" (51mm)	5.25" (133mm)
XLP2G-2100	21.00" (533mm)	4.00" (102mm)	42.00" (1,067mm)	31.50" (800mm)	5.25" (133mm)	2.00" (51mm)	5.25" (133mm)
XLP2G-2200	22.00" (559mm)	4.00" (102mm)	44.00" (1,118mm)	32.50" (826mm)	5.25" (133mm)	2.00" (51mm)	5.25" (133mm)
XLP2G-2300	23.00" (584mm)	4.00" (102mm)	46.00" (1,168mm)	33.50" (851mm)	5.25" (133mm)	2.00" (51mm)	5.25" (133mm)
XLP2G-2400	24.00" (610mm)	4.00" (102mm)	48.00" (1,219mm)	34.50" (876mm)	5.25" (133mm)	2.00" (51mm)	5.25" (133mm)
XLP2G-2300	23.00" (584mm)	4.00" (102mm)	46.00" (1,168mm)	33.50" (851mm)	5.25" (133mm)	2.00" (51mm)	5.25" (133mm)
XLP2G-2400	24.00" (610mm)	4.00" (102mm)	48.00" (1,219mm)	34.50" (876mm)	5.25" (133mm)	2.00" (51mm)	5.25" (133mm)

Contact factory for custom applications.

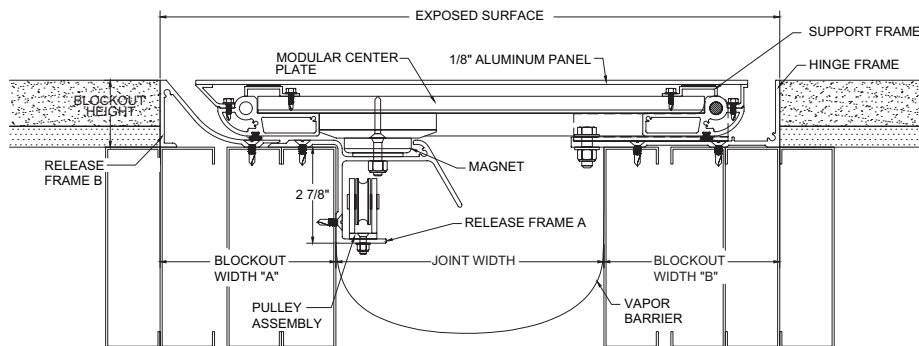

XLP-2G

XLP-2G & XLPC-2G

MODEL	JOINT WIDTH	MINIMUM OPENING	MAXIMUM OPENING	EXPOSED SURFACE	BLOCKOUT WIDTH "A"	BLOCKOUT HEIGHT	BLOCKOUT WIDTH "B"
XLPC2G-800	8.00" (203mm)	4.25" (108mm)	16.00" (406mm)	13.25" (337mm)	5.25" (133mm)	2.00" (51mm)	N/A
XLPC2G-900	9.00" (229mm)	4.25" (108mm)	18.00" (457mm)	14.25" (362mm)	5.25" (133mm)	2.00" (51mm)	N/A
XLPC2G-1000	10.00" (254mm)	4.81" (122mm)	20.00" (508mm)	15.25" (387mm)	5.25" (133mm)	2.00" (51mm)	N/A
XLPC2G-1100	11.00" (279mm)	4.81" (122mm)	22.00" (559mm)	16.25" (413mm)	5.25" (133mm)	2.00" (51mm)	N/A
XLPC2G-1200	12.00" (305mm)	4.81" (122mm)	24.00" (610mm)	17.25" (438mm)	5.25" (133mm)	2.00" (51mm)	N/A
XLPC2G-1300	13.00" (330mm)	4.81" (122mm)	26.00" (660mm)	18.25" (464mm)	5.25" (133mm)	2.00" (51mm)	N/A
XLPC2G-1400	14.00" (356mm)	4.81" (122mm)	28.00" (711mm)	19.25" (489mm)	5.25" (133mm)	2.00" (51mm)	N/A
XLPC2G-1500	15.00" (381mm)	4.81" (122mm)	30.00" (762mm)	20.25" (514mm)	5.25" (133mm)	2.00" (51mm)	N/A
XLPC2G-1600	16.00" (406mm)	4.81" (122mm)	32.00" (813mm)	21.25" (540mm)	5.25" (133mm)	2.00" (51mm)	N/A
XLPC2G-1700	17.00" (432mm)	4.81" (122mm)	34.00" (864mm)	22.25" (565mm)	5.25" (133mm)	2.00" (51mm)	N/A
XLPC2G-1800	18.00" (457mm)	4.81" (122mm)	36.00" (914mm)	23.25" (591mm)	5.25" (133mm)	2.00" (51mm)	N/A
XLPC2G-1900	19.00" (483mm)	4.81" (122mm)	38.00" (965mm)	24.25" (616mm)	5.25" (133mm)	2.00" (51mm)	N/A
XLPC2G-2000	20.00" (508mm)	4.81" (122mm)	40.00" (1,016mm)	25.25" (641mm)	5.25" (133mm)	2.00" (51mm)	N/A
XLPC2G-2100	21.00" (533mm)	4.81" (122mm)	42.00" (1,067mm)	26.25" (667mm)	5.25" (133mm)	2.00" (51mm)	N/A
XLPC2G-2200	22.00" (559mm)	4.81" (122mm)	44.00" (1,118mm)	27.25" (692mm)	5.25" (133mm)	2.00" (51mm)	N/A
XLPC2G-2300	23.00" (584mm)	4.81" (122mm)	46.00" (1,168mm)	28.25" (718mm)	5.25" (133mm)	2.00" (51mm)	N/A
XLPC2G-2400	24.00" (610mm)	4.81" (122mm)	48.00" (1,219mm)	29.25" (743mm)	5.25" (133mm)	2.00" (51mm)	N/A

Contact factory for custom applications.

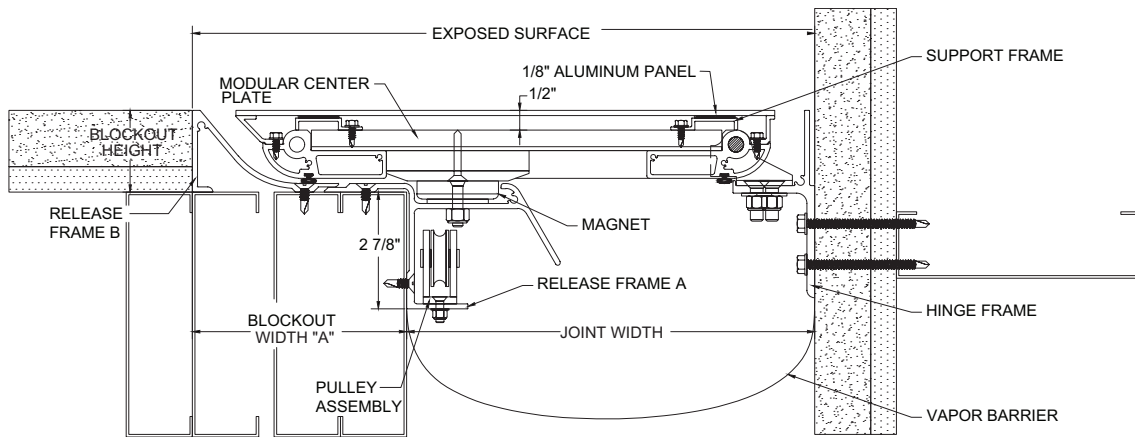

XLPC-2G