

CORNER GUARD: FINISH: _____ GAUGE: _____ TYPE: _____ CORNER GUARDS SUPPLIED IN STANDARD 16 GAUGE, TYPE #304 ALLOY WITH #4 SATIN FINISH. OPTIONAL POWDER COAT FINISHES ARE AVAILABLE. PLEASE ADVISE OPTIONAL POWDER COAT FINISH IF REQUIRED. OPTIONAL GAUGE (14, 18, 20) AND ALLOY TYPES (#316, #430) AVAILABLE. PLEASE ADVISE OPTIONAL GAUGE AND ALLOY TYPE IF REQUIRED.	MODEL	UNITS REQ'D	*UNIT HEIGHT	ANGLE	LEG LENGTH	NOSE RAD.

NOTES:

- CORNER GUARDS ARE SHIPPED WITH A PROTECTIVE STRIPPABLE COATING.
- CO-8 CORNER GUARDS HAVE A STANDARD ANGLE OF 90°, LEG LENGTH OF 3 1/2" [89.0mm] AND A STANDARD NOSE RADIUS OF 3/16" [4.8mm]. CO-8M CORNER GUARDS HAVE A STANDARD ANGLE OF 135°, LEG LENGTH OF 3 1/2" [89.0mm] AND A STANDARD NOSE RADIUS OF 3/16" [4.8mm]. PLEASE ADVISE IF A DIFFERENT LEG LENGTH, ANGLE OR BULL NOSE RADIUS (AVAILABLE IN 1/2" [12.7mm] AND 3/4" [19.15mm] RADIUS) IS DESIRED.
- CORNER GUARDS HAVE A MINIMUM LEG LENGTH OF 1" [25.4mm] AND MINIMUM NOSE RADIUS OF 3/16" [4.8mm].
- ANGLES ONLY AVAILABLE BETWEEN 45° - 178°.
- *CORNER GUARDS CAN BE USED AT FULL OR PARTIAL HEIGHTS. PLEASE ADVISE SPECIFIED UNIT HEIGHT OF CORNER GUARD.*

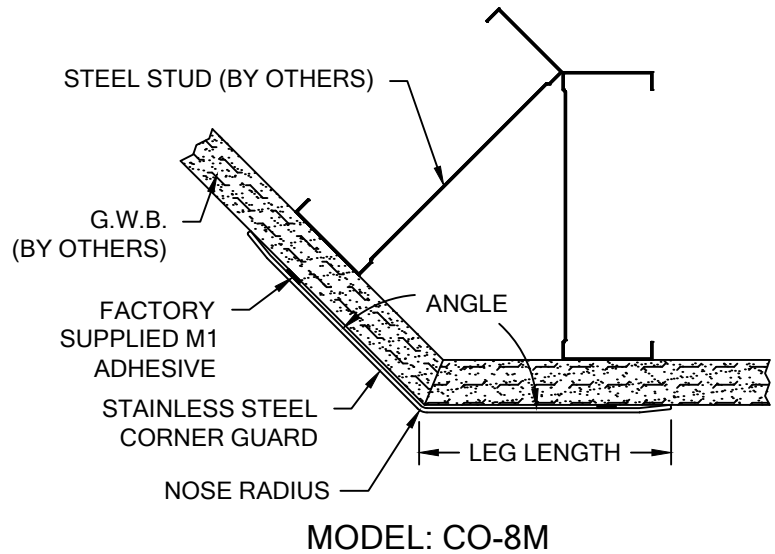
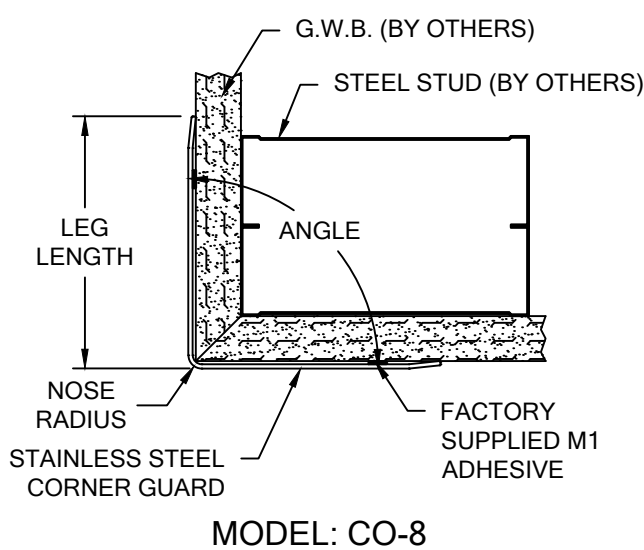

**CO-8 SERIES
CORNER GUARD
WITH ADHESIVE**

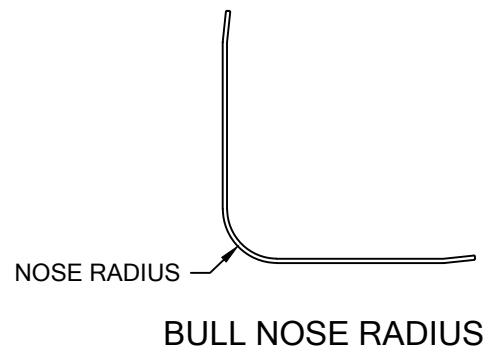

WALL CONDITION	SPECIFIED FASTENER	QUANTITY	CS PART NUMBER
STEEL STUD/GYPSUM WALL CONCRETE/CONC. BLOCK WOOD STUD/GYPSUM WALL	M1 STRUCTURAL ADHESIVE (85 L/F COVERAGE PER TUBE)	28 FL. OZ	90M135001

 Hughesville, PA 800.233.8493 570.546.5941 Mississauga, ON 888.895.8955 905.274.3611 www.c-sgroup.com © Copyright 2017 Construction Specialties, Inc.	PROJECT:	REVISION:
	JOB NO.:	F&F:
	CUSTOMER:	
	REP:	DATE:
	DRAWN BY:	SHEET NO: