

PEDIGRID WITH ALUMINUM Z EDGE FRAME / WITH DRAIN PAN

INSERT STYLE: INSERT COLOR: PLEASE ADVISE CATALOG NUMBER: G1 PART NUMBER:

| | | | |
|-----|-------------|------|----|
| NO. | REVISION | DATE | BY |
| NO. | F&F RELEASE | DATE | BY |
| | | | |
| | | | |

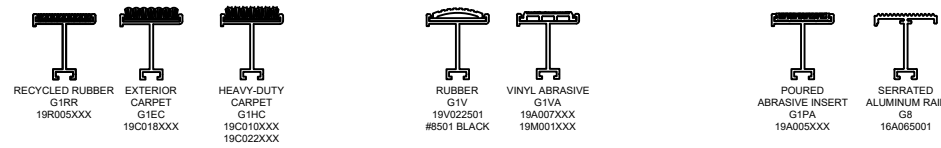

PEDIGRID INSERT STYLES

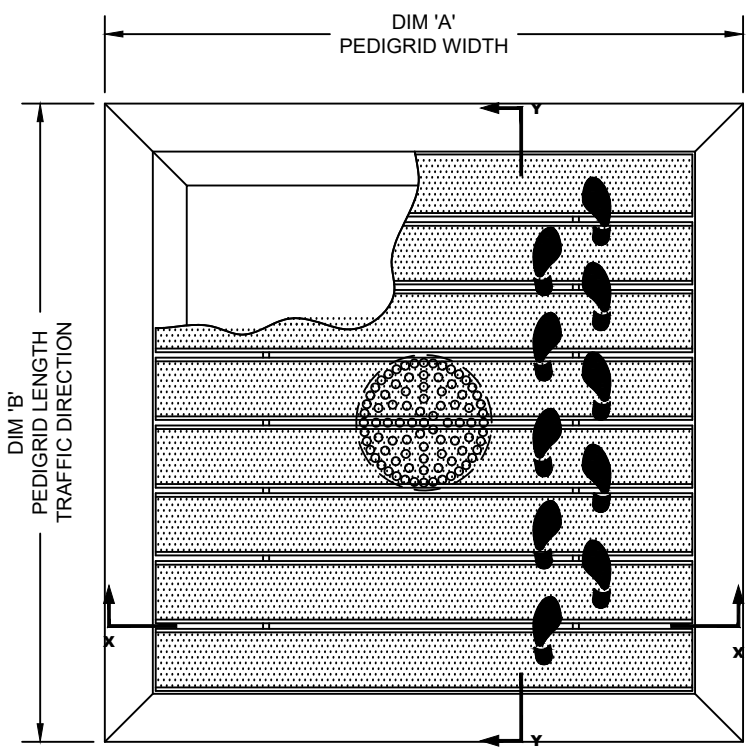

TYPICAL PLAN VIEW

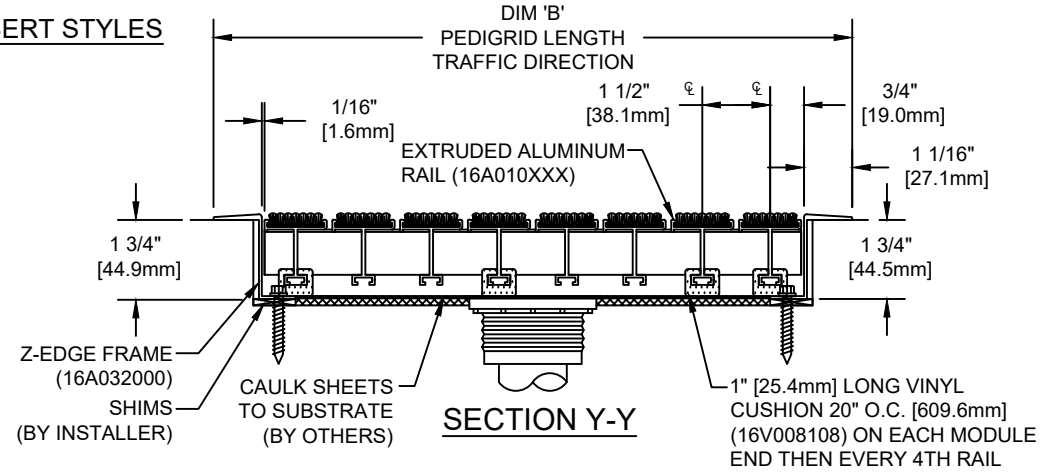

SECTION Y-Y

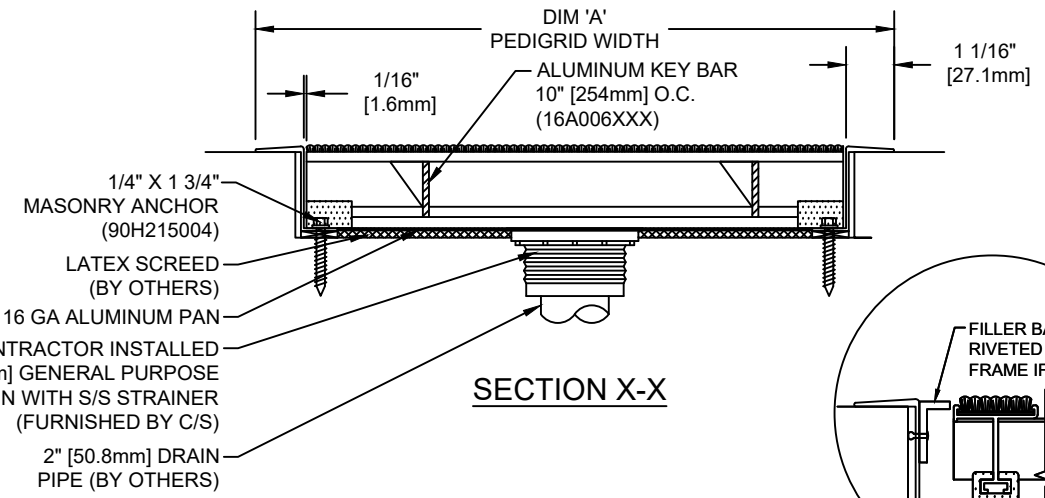

SECTION X-X

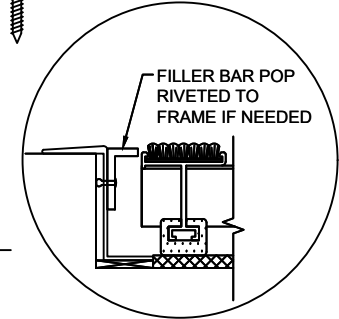

NOTES:

*GRIDS OVER STRUCTURES @ 32" O.C. TO SUPPORT A MAX LOAD OF 300 LBS PER SQ. FT. ALL GRIDS WITH LEVEL BASE FRAME TO SUPPORT A 400 LB. ROLLING LOAD. LARGER LOADING MAY BE ACCOMMODATED. CONTACT C/S SALES WITH SPECIFIC LOADING REQUIREMENTS.

*PLEASE VERIFY TRAFFIC DIRECTION.

*MAXIMUM MODULE SIZE OF GRID NOT TO EXCEED 12'-0" [3.6M] IN WIDTH (DIM "A") & 3'-0" [.91M] IN LENGTH T.D. (DIM "B").

*DUE TO 1 1/2" MODULE OF PEDIGRID, INSIDE OF FRAME DIMENSION SHOULD BE CHANGED ONLY IN INCREMENTS OF 1 1/2" [38.1mm] TO AVOID THE USE OF FILLER BARS.

*ADDITIONAL SPECIFICATIONS ARE CONTAINED IN THE LATEST C/S CATALOG OR AT C-SGROUP.COM AND ARE CONSIDERED PART OF THIS TRANSMITTAL.

| PLEASE VERIFY ALL | QTY | MARK # | LOCATION | MODEL | DIM 'A' WIDTH | DIM 'B' LENGTH | FINISH | REMARKS |
|-------------------|-----|--------|----------|-------|---------------|----------------|--------|---------|
| | | | | | | | | |
| | | | | | | | | |
| | | | | | | | | |
| | | | | | | | | |

8696 Route 405 Highway, Muncy PA 17756
 (800) 233-8493 • Fax: (570) 546-4692 • www.c-sgroup.com

| | | |
|-------------|-------|----------|
| PROJECT: | | |
| LOCATION: | | |
| CONTRACTOR: | | |
| AGENT: | | SHT: |
| DRG. BY: | DATE: | JOB NO.: |