

1 1/8" GRIDLINE WITH DEEP PIT FRAME AND HIDDEN LOCK DOWNS

NO.	REVISION	DATE	BY
NO.	F&F RELEASE	DATE	BY

INSERT STYLE: N/A INSERT COLOR: N/A CATALOG NUMBER: G6 PART NUMBER:

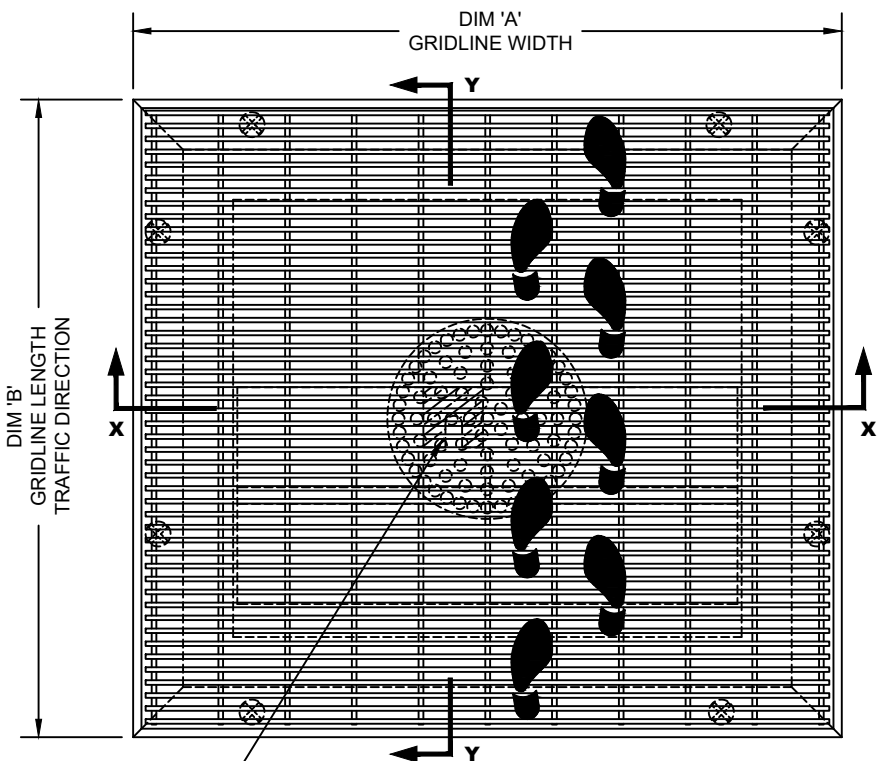

TYPICAL PLAN VIEW

.090" X 3/4" X 7/8" SLOTTED HOLD-DOWN PLATE 1 AT EACH CORNER THEN SPACE 24" TO 30" O.C. ALL FACING THE SAME DIRECTION. (90F036001)

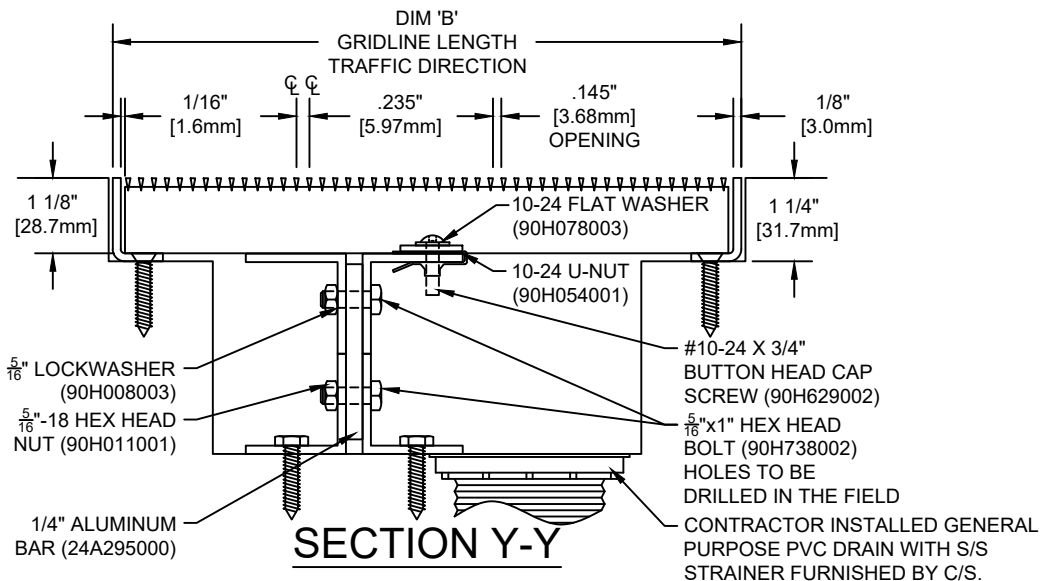

SECTION Y-Y

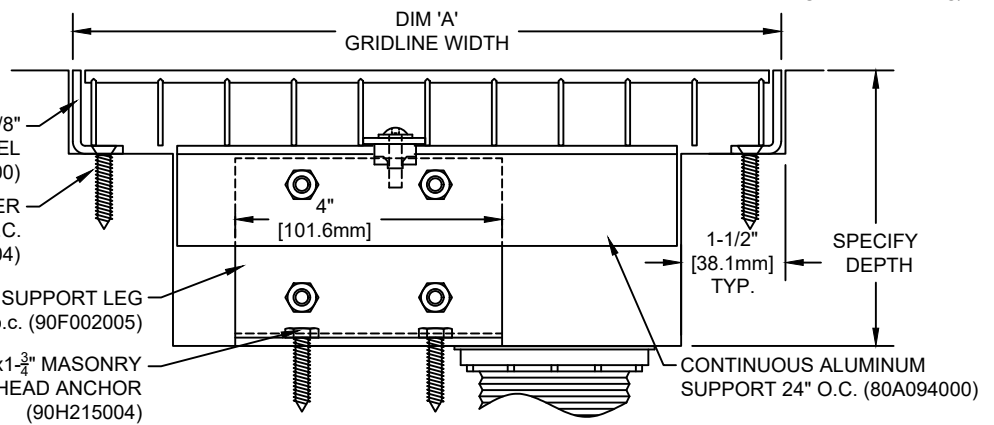

SECTION X-X

NOTES:

*MAX. SINGLE GRID SIZE NOT TO EXCEED 95-1/4" [2.419M] IN WIDTH (DIM 'A') AND 49-1/16" [1.246M] IN LENGTH (DIM 'B')
 **ALL SURFACE WIRES AND SUPPORT BARS ARE ELECTRICALLY RESISTANCE WELDED TO ENSURE CORRECT WEIGHT BEARING PROPERTIES.
 *GRIDS SHALL BE ABLE TO SUPPORT A 300 LB/SQ FT UNIFORM LOAD.

*SURFACE WIRE SPACING PROVIDES A 57.7% EFFECTIVE OPEN AREA FOR DIRT AND MOISTURE REMOVAL.
 **ADDITIONAL SPECIFICATIONS ARE CONTAINED IN THE LATEST C/S CATALOG OR AT C-SGROUP.COM AND ARE CONSIDERED PART OF THIS TRANSMITTAL.

CS Construction Specialties
 6536 Route 405 Highway, Muncy PA 17756
 (800) 233-8493 • Fax: (570) 546-6692 • www.c-sgroup.com

PLEASE VERIFY ALL	QTY	MARK #	LOCATION	MODEL	DIM 'A' WIDTH	DIM 'B' LENGTH	FRAME FINISH	REMARKS

PROJECT:		
LOCATION:		
CONTRACTOR:		
AGENT:		SHT:
DRG. BY:	DATE:	JOB NO.: