

**P-OMM HANDRAIL**

PLEASE READ

PLEASE READ THESE INSTRUCTIONS THOROUGHLY PRIOR TO BEGINNING THE P-OMM HANDRAIL INSTALLATION!

THIS INSTRUCTION SHEET IS INTENDED TO PROVIDE A SPECIFIC GUIDE TO FOLLOW FOR THE INSTALLATION OF THIS P-OMM HANDRAIL. CONTAINED WITHIN IS THE TECHNICAL INFORMATION AND INSTALLATION TECHNIQUES REQUIRED TO COMPLETE AN EFFICIENT, NEAT AND LONG-LASTING INSTALLATION.

INSPECT ALL MATERIALS FOR DAMAGE OR MISSING PARTS. IF YOU DISCOVER DAMAGED OR MISSING MATERIALS, IN THE USA PLEASE NOTIFY THE FACTORY AT (800) 233-8493, AND IN CANADA (888) 895-8955 FOR CUSTOMER SERVICE.

P-OMM HANDRAIL MUST BE INSTALLED IN ACCORDANCE WITH THESE INSTRUCTIONS! FAILURE TO FOLLOW THESE INSTRUCTIONS MAY VOID ANY PRODUCT WARRANTIES AND RESULT IN AN UNSUCCESSFUL INSTALLATION. FOR SPECIFIC QUESTIONS REGARDING THE INSTALLATION OF THIS P-OMM HANDRAIL PLEASE CALL THE FACTORY IN THE USA AT (800) 233-8493 OR EMAIL [IWPTECHSUPPORT@C-SGROUP.COM](mailto:IWPTECHSUPPORT@C-SGROUP.COM). IN CANADA CALL (888) 895-8955.

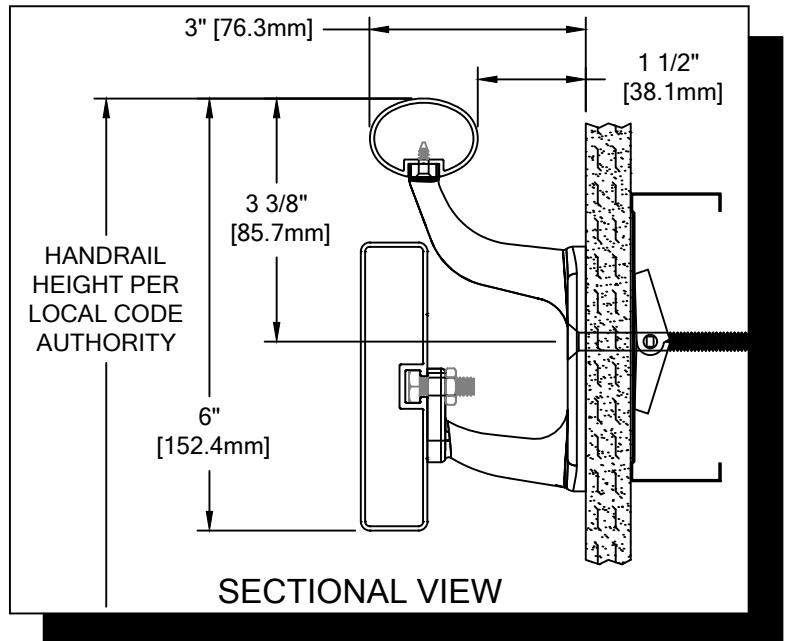

IMPORTANT NOTES

1. ALL LINEAL MATERIAL TO BE SUPPLIED IN STOCK LENGTHS. POWDER COATED HANDRAIL IN 12'-0" LENGTHS. THIS MATERIAL IS TO BE FIELD CUT USING QUALITY EQUIPMENT TO INSURE THAT ALL CUTS ARE SQUARE. WHEN CUTTING MATERIAL SECTIONS, C/S RECOMMENDS USING AN 80-100 TOOTH CARBIDE TIPPED SAW BLADE OR EQUIVALENT, TO MINIMIZE CHIPPING AND MAINTAIN JOINT ALIGNMENT.
2. ALL DIMENSIONS ARE TYPICAL.
3. FOR DRYWALL/PLASTER WALL CONSTRUCTION, IT IS RECOMMENDED FOR FASTENERS TO BE ENGAGED INTO METAL/WOOD STUDS TO MAINTAIN MAXIMUM PULLOUT STRENGTH. IF DURING INSTALLATION YOU ENCOUNTER SPECIAL WALL CONDITIONS THAT DO NOT ALLOW FOR DIRECT ATTACHMENT TO STUDS PLEASE CONSULT THE LOCAL AUTHORITY HAVING JURISDICTION.
4. INSTALL OUTSIDE CORNERS FIRST.
5. INSTALL LONGEST RUN OF HANDRAIL FIRST.
6. HANDRAIL AND CRASH RAIL SPLICE SHOULD NOT EXCEED 3" [76.2mm] DISTANCE FROM A BRACKET.
7. MATERIAL MUST REACH 65°F MIN. TO 75° MAX. 24 HOURS PRIOR TO INSTALLATION. THIS IS ESSENTIAL TO MINIMIZE EXPANSION AND CONTRACTION.
8. MAY REQUIRE USE OF FIRE PUTTY WHEN INSTALLED ON FIRE WALL WITH TOGGLE BOLTS. REFERENCE INSTRUCTIONS 24FIREPUTTY FOR FIRE PUTTY INSTALLATION.
9. THIS HANDRAIL REQUIRES A MINIMUM OF 2 MOUNTING BRACKETS PER UNIT. THE MINIMUM END CAP-TO-END CAP HANDRAIL LENGTH IS 13 3/4" [349.1mm].
10. FOR MORE INFORMATION ON P-OMM HANDRAIL SEE OUR WEBSITE AT [www.c-sgroup.com](http://www.c-sgroup.com).

**P-OMM HANDRAIL**

COMPONENTS & WALL FASTENERS

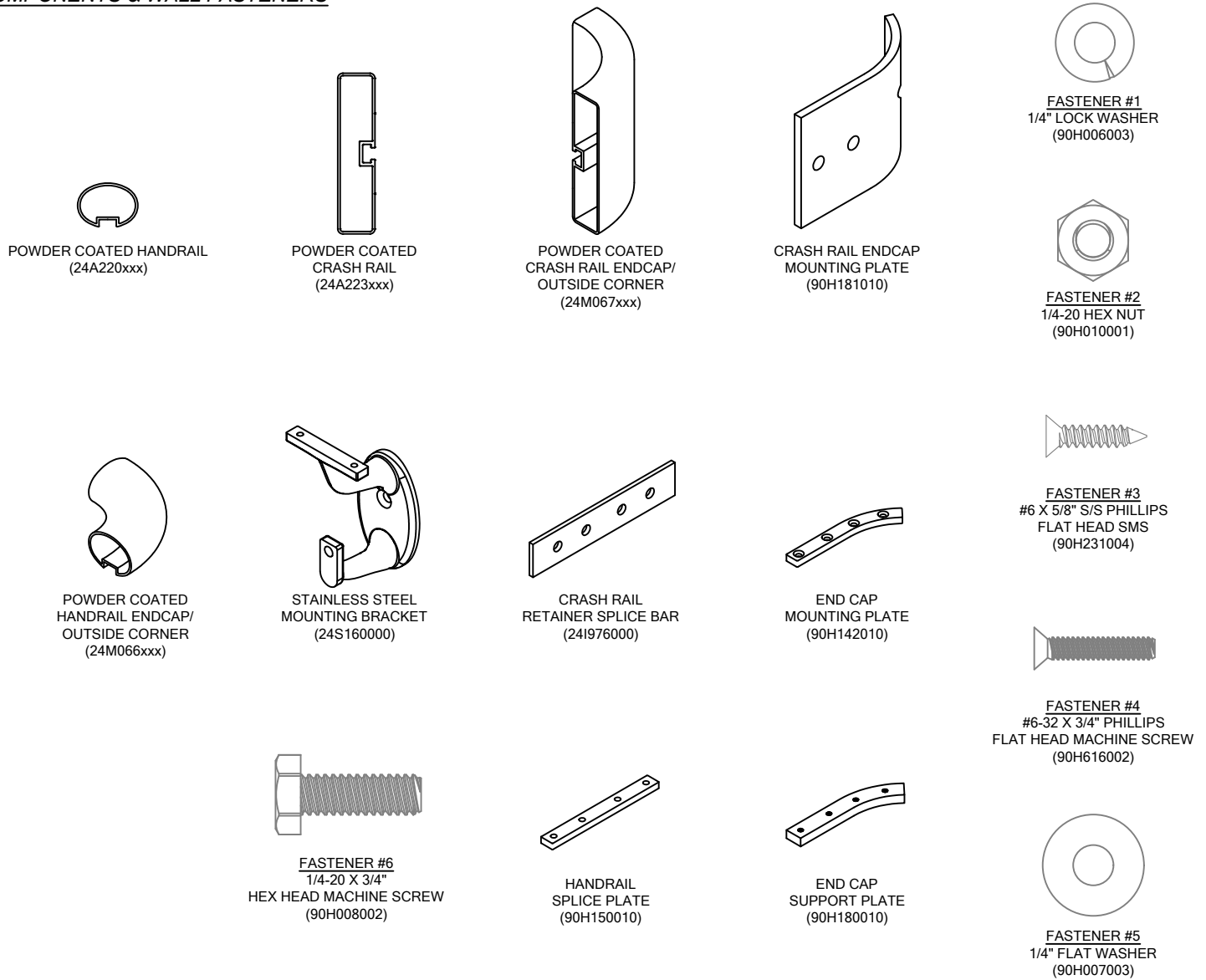

WALL CONDITION	SPECIFIED FASTENER	DRILL DIAMETERS		CS PART NUMBER
		WALL	RETAINER	
STEEL STUD/GYPSUM WALL	1/4-20 X 3" S/S FLAT HEAD BOLT WITH TOGGLE	3/4"	N/A	90H184002
CONCRETE/CONCRETE BLOCK	1/4" X 1 3/4" S/S FLAT HEAD MASONRY ANCHOR	3/16"	N/A	90H390000
WOOD STUD/GYPSUM WALL	#14 X 3" S/S PHILLIPS FLAT HEAD WOOD SCREW	7/32"	N/A	90H538004
16 GA. MIN. STEEL STUD AND 16 GA. MIN. STEEL STRAPPING / GYPSUM WALL CONSTRUCTION REQUIRED (TEK SCREWS)	#14 X 3" PHILLIPS FLAT HEAD SELF DRILLING S/S TEK SCREW	N/A	N/A	90H230003

P-OMM HANDRAIL

LAYOUT VIEW

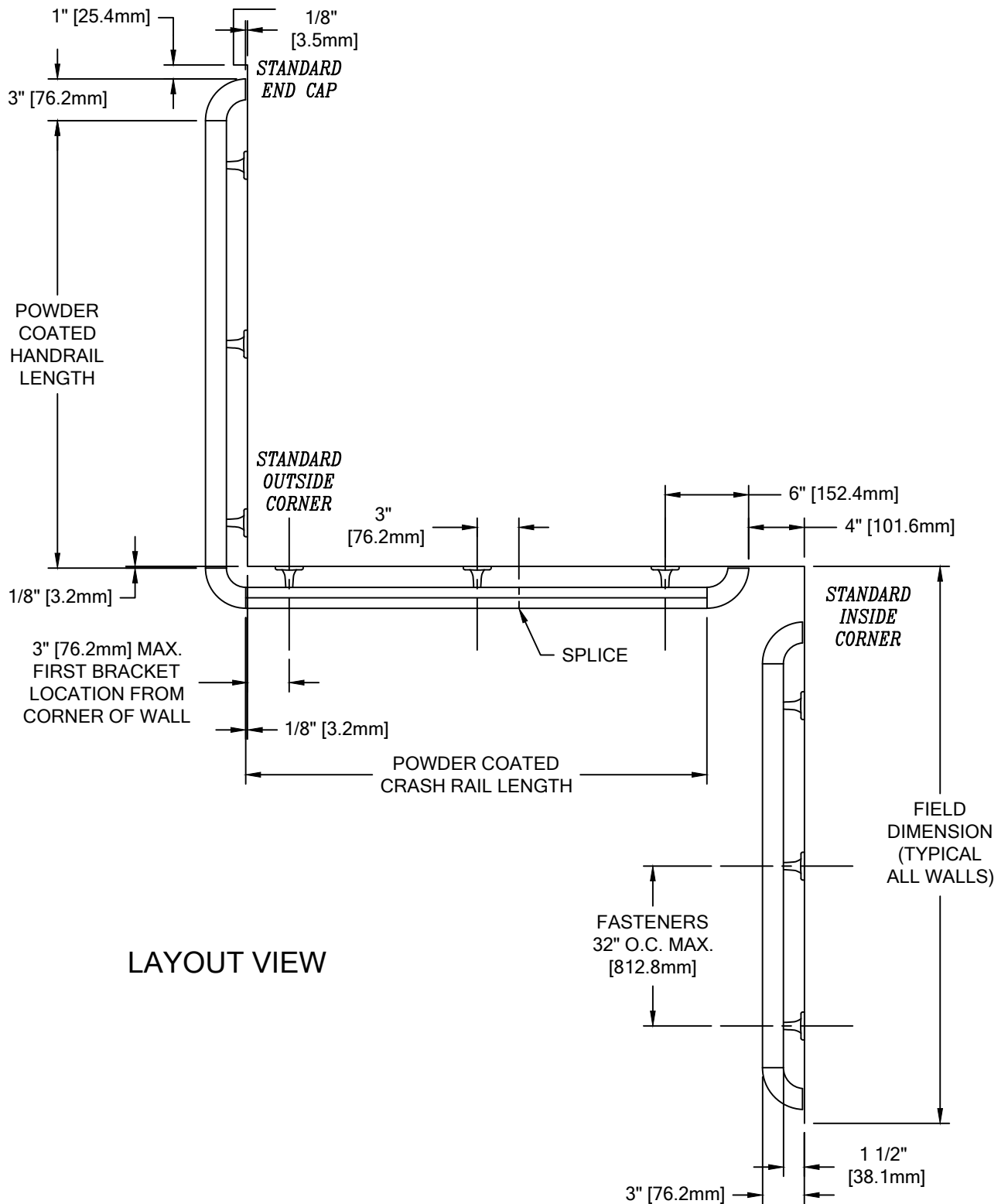

LAYOUT VIEW

**P-OMM HANDRAIL**

TYPICAL ASSEMBLY

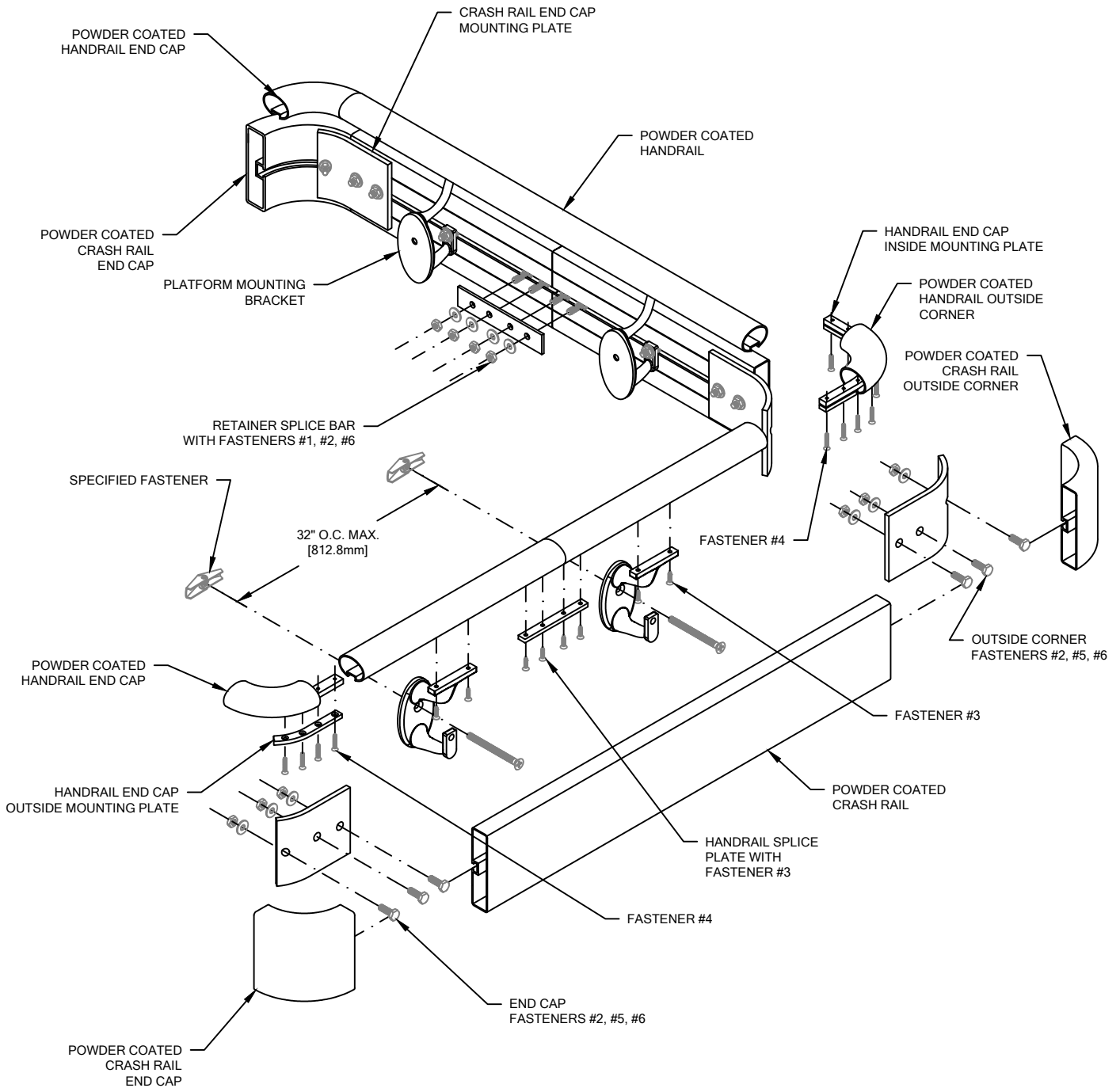

**P-OMM HANDRAIL**

TYPICAL HANDRAIL ASSEMBLY

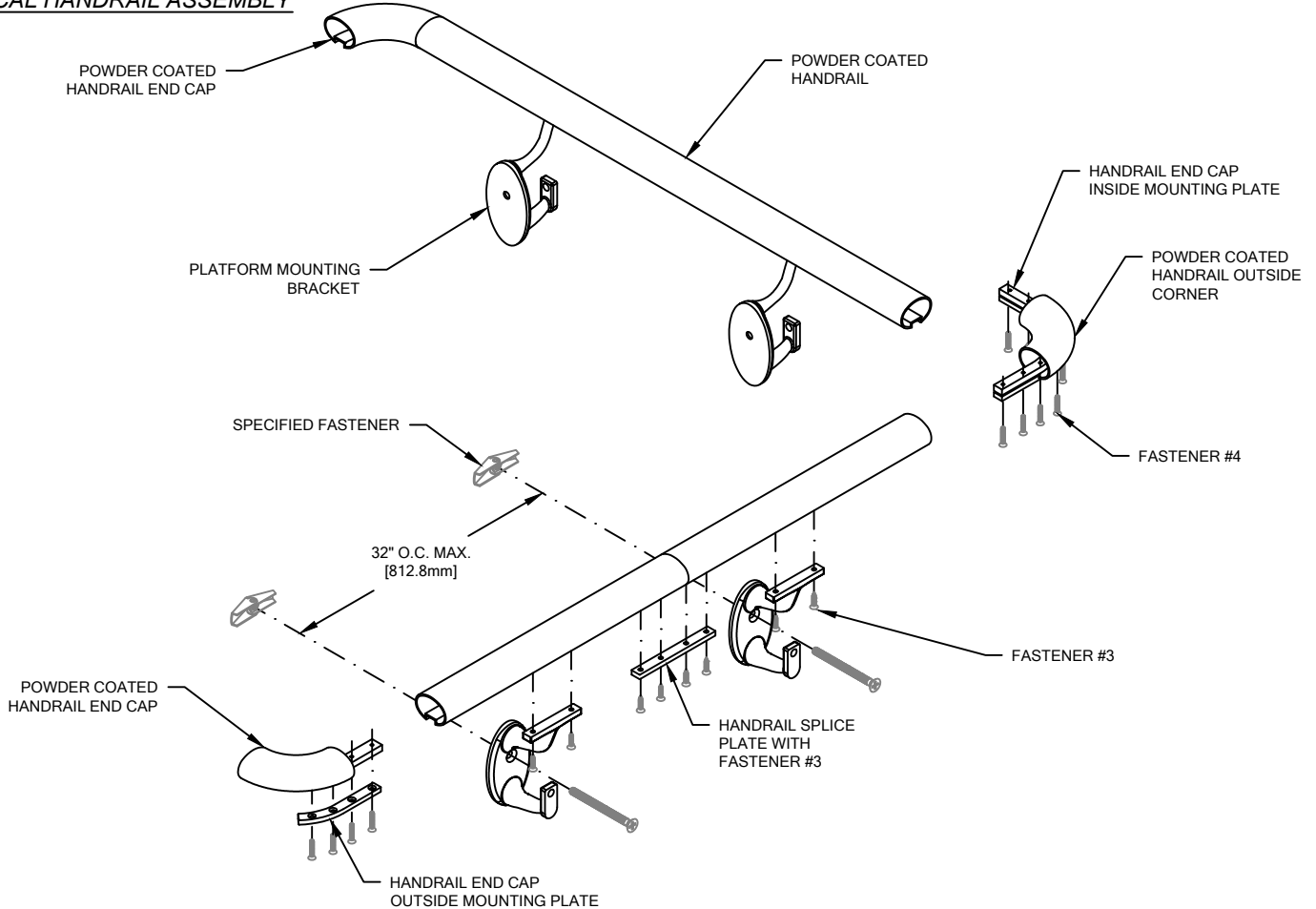

1. USING "LOCAL CODE" REQUIREMENTS, ESTABLISH HANDRAIL HEIGHT ABOVE FINISH FLOOR. DEDUCT 3 3/8" [85.7mm] AND SNAP A CHALK LINE AT THAT HEIGHT. THIS MARKS THE LOCATION OF THE HOLE FOR THE MOUNTING BRACKET FASTENERS.
2. DRILL CLEARANCE HOLES IN WALL SURFACE FOR MOUNTING HARDWARE. REFERENCE CHART ON PAGE 2 FOR CORRECT DRILL DIAMETERS.
3. INSTALL MOUNTING BRACKETS USING APPROPRIATE FASTENERS. DO NOT OVER TORQUE THE FASTENERS. USE A LEVEL TO ENSURE THAT THE BRACKETS ARE LEVEL.

**NOTE:** SEE LAYOUT VIEW TO AID IN MOUNTING BRACKET LOCATION.

4. CUT THE CONTINUOUS POWDER COATED HANDRAIL TO LENGTH USING THE REQUIRED DEDUCTIONS (SEE LAYOUT VIEW).

**NOTE:** IT IS RECOMMENDED THAT CONTINUOUS POWDER COATED HANDRAIL BE CUT WITH AN 80-100 TOOTH CARBIDE TIPPED SAW BLADE OR EQUIVALENT.

5. ATTACH END CAPS AND OUTSIDE CORNERS:
  - ALIGN HANDRAIL WITH END CAP SO THEY ARE FLUSH TOGETHER.
  - USING OUTSIDE MOUNTING PLATE AS A TEMPLATE, PLACE INTO GROOVE AND MARK LOCATIONS.
  - REMOVE OUTSIDE MOUNTING PLATE AND DRILL HOLES (1/8" DRILL  $\phi$ ).
  - ALIGN HOLES OF INSIDE MOUNTING PLATE, HANDRAIL AND OUTSIDE MOUNTING PLATE.
  - ATTACH USING #6-32 X 3/4" FH MACHINE SCREWS. DO NOT FULLY SECURE.
  - REPOSITION END CAP AND ATTACH USING #6-32 X 3/4" FH MACHINE SCREWS.
  - SECURELY TIGHTEN ALL FASTENERS.
6. DRILL 1/16" PILOT HOLES INTO THE POWDER COATED HANDRAIL FOR MOUNTING BRACKET ATTACHMENT. MOUNTING BRACKETS ARE TO BE LOCATED 3" [76.2mm] FROM EACH END OF THE POWDER COATED HANDRAIL AND 32" [612.6MM] ON CENTER ALONG LENGTH, AS REQUIRED.
7. FASTEN THE POWDER COATED HANDRAIL TO THE WALL BRACKETS IN SUCCESSION BY INSERTING TWO #6 X 5/8" PHILLIPS FLAT HEAD SHEET METAL SCREWS THROUGH THE UNDERSIDE OF BRACKET INTO THE POWDER COATED HANDRAIL. CAUTION: OVER-TORQUEING MAY CAUSE THE FASTENERS TO STRIP.

P-OMM HANDRAIL

TYPICAL CRASH RAIL ASSEMBLY

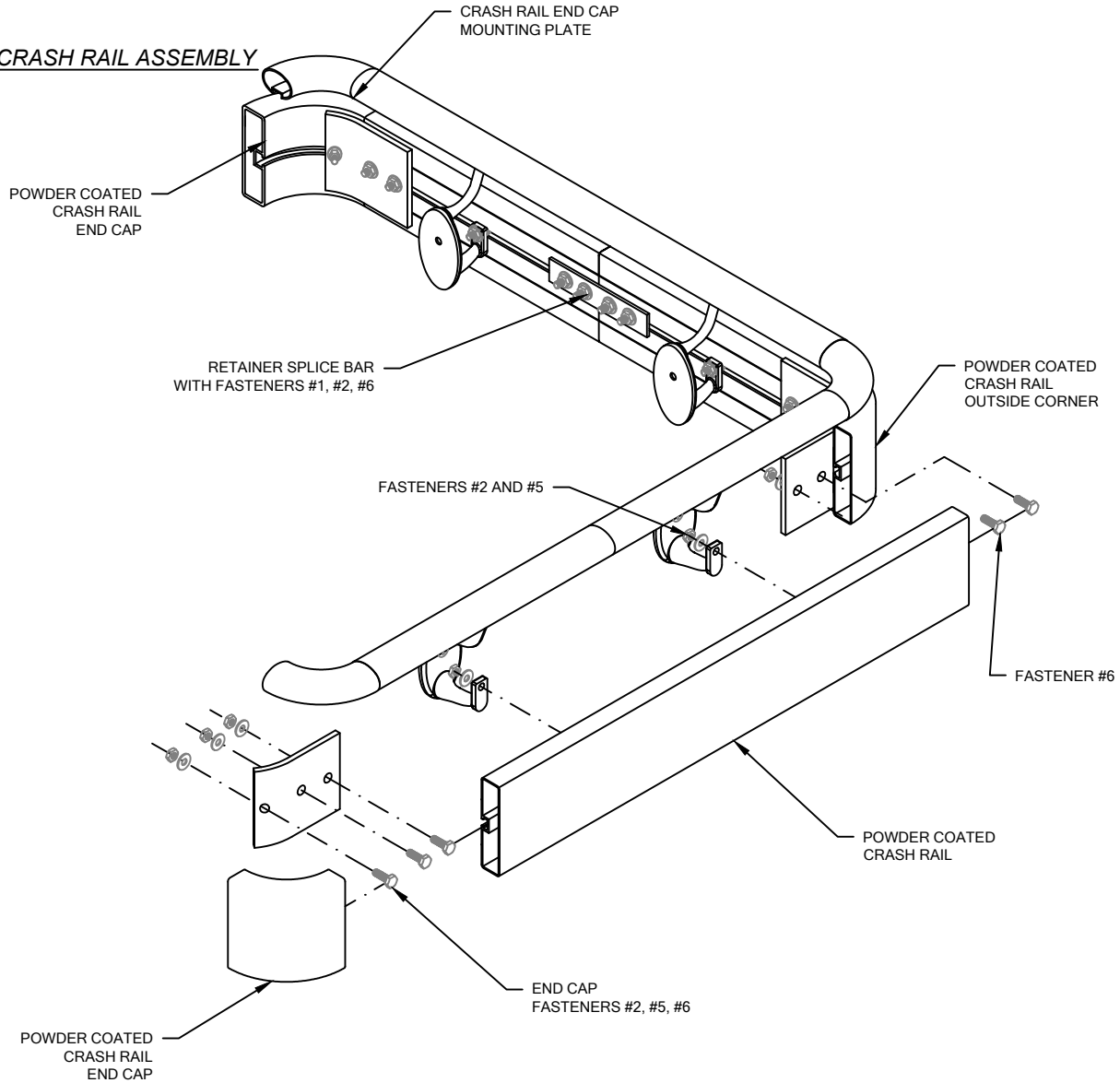

8. CUT THE CONTINUOUS POWDER COATED CRASH RAIL TO LENGTH USING THE REQUIRED DEDUCTIONS (SEE LAYOUT VIEW).

**NOTE:** IT IS RECOMMENDED THAT CONTINUOUS POWDER COATED CRASH RAIL BE CUT WITH AN 80-100 TOOTH CARBIDE TIPPED SAW BLADE OR EQUIVALENT.

9. ATTACH POWDER COATED CRASH RAIL END CAPS AND OUTSIDE CORNERS:

- SLIDE 1/4-20 X 3/4" HEX HEAD BOLTS IN THE RECEIVER SLOT OF THE CRASH RAIL RETAINER FOR ALL WALL BRACKETS.
- PARTIALLY FASTEN 1/4-20 X 3/4" HEX HEAD BOLTS ONTO MOUNTING PLATE (NOTE THE ORIENTATION IN DRAWING ABOVE).
- SLIDE HEAD OF BOLTS INTO GROOVES OF THE CRASH RAIL AND END CAP.
- ALIGN CRASH RAIL WITH END CAP SO THEY ARE FLUSH TOGETHER.
- SECURELY TIGHTEN ALL FASTENERS.

10. ATTACH POWDER COATED CRASH RAIL TO THE WALL BRACKETS:

- ALIGN HEX HEAD BOLT WITH MOUNTING BRACKETS.
- INSERT HEX HEAD BOLT INTO THE MOUNTING BRACKET HOLE.
- PLACE A 1/4" FLAT WASHER AND 1/4-20 HEX NUT ONTO THE HEX HEAD BOLT.
- TIGHTEN AS REQUIRED.

11/9/18