

## HRW-20CM HANDRAIL

WITH LIGATURE RESISTANT MOUNTING BRACKET

### PLEASE READ

PLEASE READ THESE INSTRUCTIONS THOROUGHLY PRIOR TO BEGINNING THE HRW-20CM HANDRAIL INSTALLATION!

THIS INSTRUCTION SHEET IS INTENDED TO PROVIDE A SPECIFIC GUIDE TO FOLLOW FOR THE INSTALLATION OF THIS HRW-20CM HANDRAIL. CONTAINED WITHIN IS THE TECHNICAL INFORMATION AND INSTALLATION TECHNIQUES REQUIRED TO COMPLETE AN EFFICIENT, NEAT AND LONG-LASTING INSTALLATION.

INSPECT ALL MATERIALS FOR DAMAGE OR MISSING PARTS. IF YOU DISCOVER DAMAGED OR MISSING MATERIALS, IN THE USA PLEASE NOTIFY THE FACTORY AT (800) 233-8493, AND IN CANADA (888) 895-8955 FOR CUSTOMER SERVICE.

HRW-20CM HANDRAIL MUST BE INSTALLED IN ACCORDANCE WITH THESE INSTRUCTIONS! FAILURE TO FOLLOW THESE INSTRUCTIONS MAY VOID ANY PRODUCT WARRANTIES AND RESULT IN AN UNSUCCESSFUL INSTALLATION. FOR SPECIFIC QUESTIONS REGARDING THE INSTALLATION OF THIS HRW-20CM HANDRAIL PLEASE CALL THE FACTORY IN THE USA AT (800) 233-8493 OR EMAIL [IWPTECHSUPPORT@C-SGROUP.COM](mailto:IWPTECHSUPPORT@C-SGROUP.COM). IN CANADA CALL (888) 895-8955 .

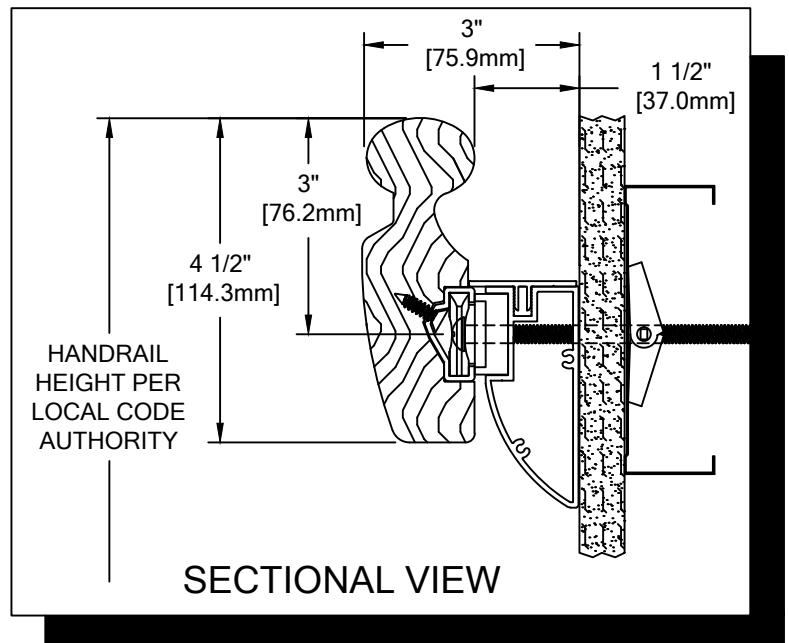

### IMPORTANT NOTES

1. DUE TO WOOD BEING A NATURAL PRODUCT, COMPONENTS MAY GROW AND SHRINK AT DIFFERENT RATES. BECAUSE OF THIS, C/S HAS DESIGNED THIS HANDRAIL TO UTILIZE A BEVEL AS SHOWN IN THESE INSTRUCTIONS (SEE FIGURE 1). THIS BEVEL MUST BE APPLIED AT ALL WOOD HANDRAIL SPLICE JOINTS.
2. DUE TO THE NATURE OF WOOD, COMPONENT COLORS MAY VARY, SORT WOOD COMPONENTS AND MATCH PARTS BY COLOR.
3. ALL LINEAL MATERIAL TO BE SUPPLIED IN STOCK LENGTHS. WOOD IN 7'-0" TO 12'-0" VARIABLE, AND ALUMINUM IN LENGTHS UP TO 20'-0". THIS MATERIAL IS TO BE FIELD CUT USING QUALITY EQUIPMENT TO INSURE THAT ALL CUTS ARE SQUARE. WHEN CUTTING MATERIAL SECTIONS, C/S RECOMMENDS USING AN 80-100 TOOTH CARBIDE TIPPED SAW BLADE OR EQUIVALENT, TO MINIMIZE CHIPPING AND MAINTAIN JOINT ALIGNMENT.
4. ALL DIMENSIONS ARE TYPICAL.
5. FOR DRYWALL/PLASTER WALL CONSTRUCTION, IT IS RECOMMENDED FOR FASTENERS TO BE ENGAGED INTO METAL/WOOD STUDS TO MAINTAIN MAXIMUM PULLOUT STRENGTH.
6. INSTALL OUTSIDE CORNERS FIRST.
7. INSTALL LONGEST RUN OF HANDRAIL FIRST.
8. ALUMINUM RETAINER SPLICES SHOULD NOT EXCEED 4" [101.6mm] DISTANCE FROM A BRACKET.
9. THE DISTANCE BETWEEN A WOOD SPLICE JOINT AND AN ALUMINUM RETAINER JOINT SHOULD BE STAGGERED 12" [304.8mm].
10. MATERIAL MUST REACH 65°F MIN. TO 75°F MAX. 24 HOURS PRIOR TO INSTALLATION. THIS IS ESSENTIAL TO MINIMIZE EXPANSION AND CONTRACTION OF MATERIAL.
11. MAY REQUIRE USE OF FIRE PUTTY WHEN INSTALLED ON FIRE WALL WITH TOGGLE BOLTS. REFERENCE INSTRUCTIONS 24FIREPUTTY FOR FIRE PUTTY INSTALLATION.
12. THIS HANDRAIL REQUIRES A MINIMUM OF 2 MOUNTING BRACKETS PER UNIT. THE MINIMUM END CAP-TO-END CAP HANDRAIL LENGTH IS 12 5/8" [320.7mm].
13. FOR MORE INFORMATION ON HRW-20CM HANDRAIL SEE OUR WEBSITE AT [www.c-sgroup.com](http://www.c-sgroup.com).

**HRW-20CM HANDRAIL**

COMPONENTS & WALL FASTENERS



WOOD HANDRAIL  
(24W410xxx)



WOOD HANDRAIL  
(24W416xxx-GROOVED)



ALUMINUM RETAINER  
(24A214000)



TOP PLATE  
(24A337000)



QUICK LOCK  
(24I821000)



**FASTENER #1**  
#10 X 3/4" PHILLIPS  
FLAT HEAD SCREW  
(90H507002)

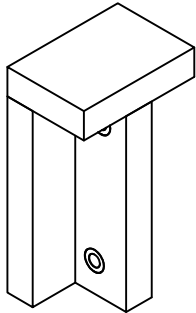

DOWEL PIN  
DRILLING JIG  
(90H219010)

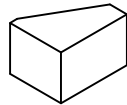

CORNER BLOCK  
(24W622xxx)



OPTIONAL STAINLESS  
STEEL INSERT  
(24S066000)



OPTIONAL FEATURE INSERT  
(24V011xxx)



LIGATURE RESISTANT  
BRACKET  
(24A336000)



CLOSING PLATE  
(24F258000)



**FASTENER #2**  
#6 X 1/2" 18-8 S/S  
PIN-IN-TORX TAMPER-RESISTANT  
SHEET METAL SCREW  
(90H881002)

WALL CONDITION	SPECIFIED FASTENER	DRILL DIAMETERS		C/S PART NUMBER
		WALL	RETAINER	
STEEL STUD/GYPSUM WALL	1/4-20 X 5" ROUND HEAD BOLT WITH TOGGLE, AND LOCK WASHER	3/4"	9/32"	90H049002 90H006003
CONCRETE/CONCRETE BLOCK	#14 X 5" PHILLIPS RD HD ALL-PURPOSE SCREW	3/16"	9/32"	90H287002
WOOD STUD/GYPSUM WALL	#14 X 5" PHILLIPS RD HD ALL-PURPOSE SCREW	1/8"	9/32"	90H287002

HRW-20CM HANDRAIL

LAYOUT VIEW

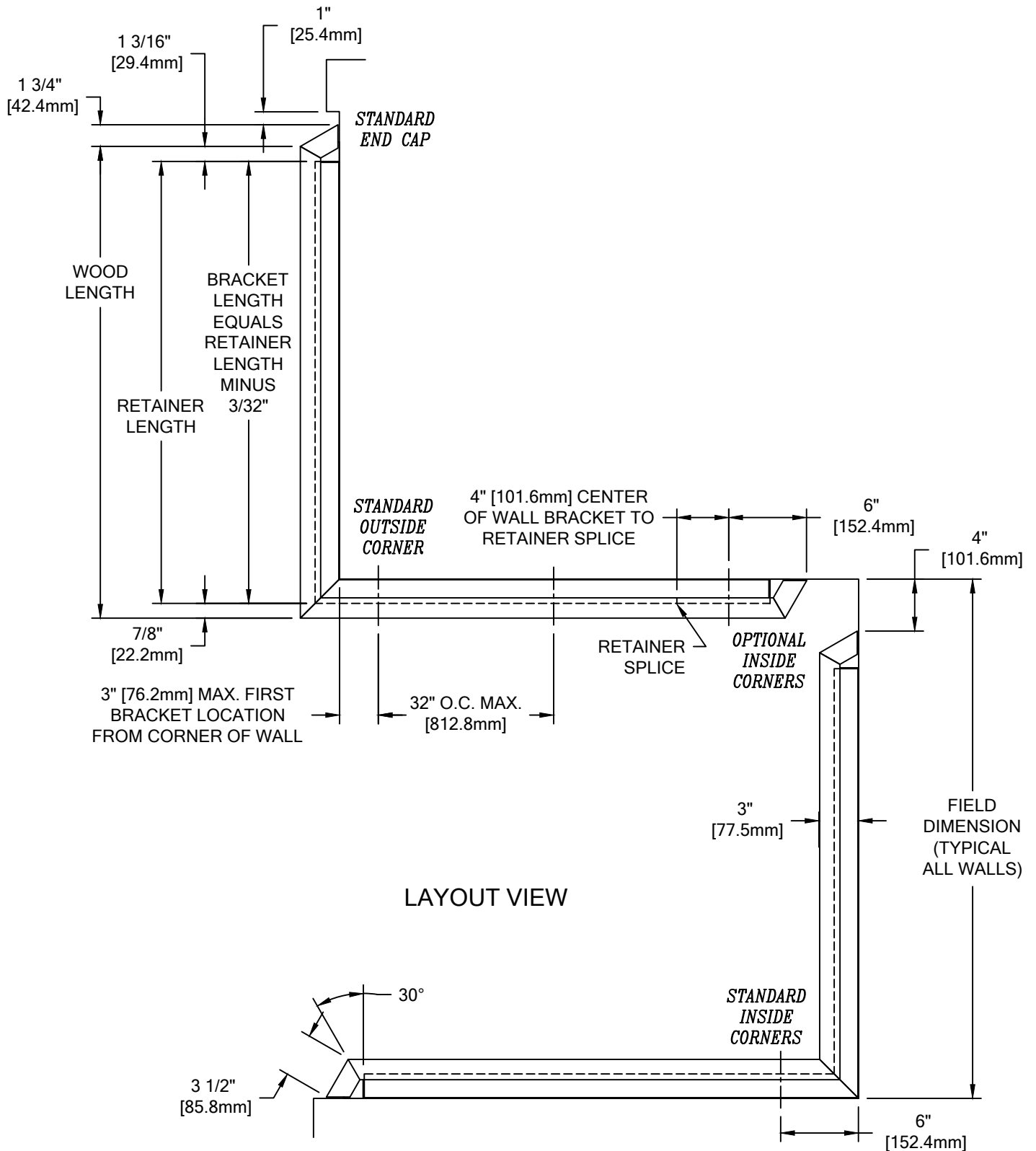

**HRW-20CM HANDRAIL**

TYPICAL ASSEMBLY

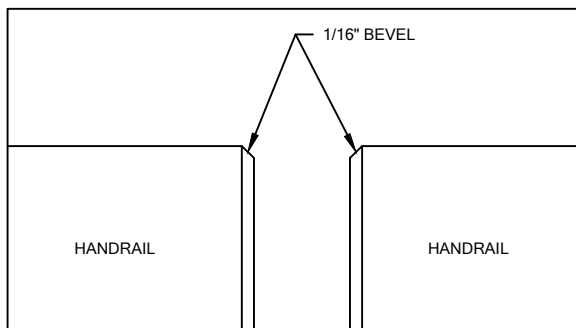
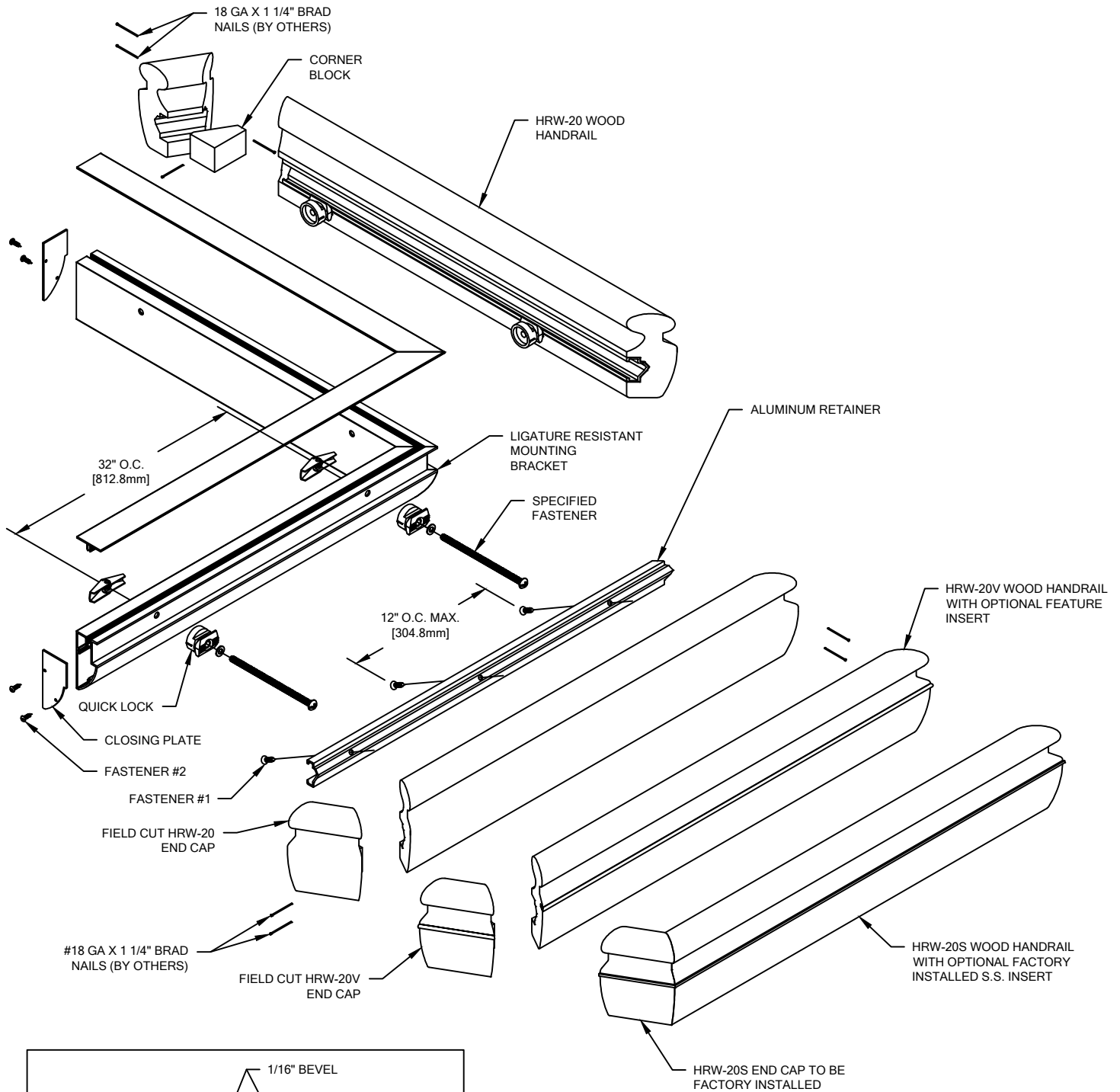

FIGURE 1.

**HRW-20CM HANDRAIL**

**TYPICAL ASSEMBLY**

1. USE LOCAL CODE REQUIREMENTS AND ESTABLISH HANDRAIL HEIGHT ABOVE FINISH FLOOR. DEDUCT 3" [76.2mm] AND SNAP A CHALK LINE AT THAT HEIGHT. THIS MARKS THE LOCATION OF THE MOUNTING BRACKET FASTENERS.
2. CUT THE LIGATURE RESISTANT MOUNTING BRACKET TO LENGTH USING THE REQUIRED DEDUCTIONS (SEE LAYOUT VIEW). PRE-DRILL CLEARANCE HOLES FOR THE SPECIFIED WALL FASTENERS IN THE LIGATURE RESISTANT MOUNTING BRACKET 3" [76.2mm] FROM EACH END. REFERENCE CHART ON PAGE 2 FOR CORRECT DRILL DIAMETERS. ALL OTHER BRACKET HOLES MUST NOT EXCEED 32" [812.8mm] ON CENTER. ATTACH ONE CLOSING PLATE WITH TWO (2) #6 x 1/2" TAMPER-RESISTANT SHEET METAL SCREWS TO EACH END OF THE LIGATURE RESISTANT BRACKET BEFORE ATTACHING TO THE WALL.
3. PLACE A QUICK LOCK AT EACH CLEARANCE HOLE ON THE LIGATURE RESISTANT BRACKET. USING THE APPROPRIATE FASTENERS, ATTACH THE BRACKET ASSEMBLIES TO THE WALL AT THE PRE-DRILLED LOCATIONS.

NOTE: IF YOUR ORDER IS A CUT-TO-SIZE JOB, GO TO STEP 8.

NOTE: IF YOUR ORDER IS A PRE-ASSEMBLED JOB, GO TO STEP 10.

4. TO DETERMINE THE HANDRAIL LENGTH, REFERENCE THE LAYOUT VIEW FOR DEDUCTIONS. ALL HANDRAIL ENDS THAT RECEIVE END CAPS ARE TO BE CUT AT A 60-DEGREE ANGLE ON THE HANDRAIL.

NOTE: IT IS RECOMMENDED THAT WOOD HANDRAIL AND ALUMINUM RETAINER BE CUT WITH 80-100 TOOTH CARBIDE TIPPED SAW BLADE OR EQUIVALENT.

5. DUE TO THE COLOR MATCH, END CAPS ARE TO BE CUT FROM THE SAME HANDRAIL SECTION. CUT THE END CAPS PER INSTRUCTIONS ON THE FOLLOWING PAGE (STEPS 5a-5c).
6. ATTACH END CAPS TO THE HANDRAIL WITH WOOD GLUE (TITEBOND IS RECOMMENDED) AND TWO 18 GA X 1 1/4" BRAD NAILS. HANDRAILS THAT INTERSECT AT INSIDE OR OUTSIDE CORNERS ARE TO BE JOINED IN THE SAME MANNER. WIPE OFF ANY EXCESS GLUE. FILL BRAD NAIL LOCATIONS USING THE PUTTY STICK SUPPLIED IN THE TOUCH UP KIT. EASE THE MITERED JOINT EDGE BY ADDING A SMALL BEVEL TO ELIMINATE SHARP EDGES. RESTAIN THE SANDED EDGE WITH THE STAIN STICK SUPPLIED IN THE TOUCH UP KIT.
7. CUT THE CONTINUOUS ALUMINUM RETAINER TO LENGTH USING THE REQUIRED DEDUCTIONS AS SHOWN ON LAYOUT VIEW.
8. FASTENERS START 2" [50.8mm] FROM THE ENDS OF RETAINER AND ARE 12" [305mm] ON CENTER. DRILL 7/32" [5.6mm] DIAMETER PILOT HOLE IN RETAINER.
9. ATTACH ALUMINUM RETAINER TO WOOD HANDRAIL. USING HOLES IN ALUMINUM RETAINER AS A TEMPLATE, DRILL 1/8" [3.2mm] DIAMETER PILOT HOLES INTO THE HANDRAIL 3/4" [19.0mm] DEEP. DO NOT DRILL THE PILOT HOLES WITHOUT A DRILL STOP.
10. REST THE RETAINER ON THE BRACKET ASSEMBLIES. USING THE WRENCH PROVIDED, TWIST EACH LOCK 90° TO SECURE THE WOOD WALL BRACKET INTO PLACE. SEE ILLUSTRATIONS 1 THROUGH 3.
11. CUT THE CONTINUOUS TOP PLATE TO THE PROPER LENGTH BY MEASURING THE DISTANCE BETWEEN THE INSTALLED END PLATE. MITER INSIDE/OUTSIDE CORNERS.
12. INSTALL THE CONTINUOUS TOP PLATE ONTO THE LIGATURE RESISTANT BRACKET BETWEEN THE INSTALLED END PLATE.
13. PLACE A WOOD BLOCK ON TOP OF THE CONTINUOUS TOP PLATE. WHILE HOLDING THE CONTINUOUS TOP PLATE SOMEWHAT LEVEL, USE A RUBBER Mallet TO STRIKE THE WOOD BLOCK. (NOTE: DO NOT HAMMER DIRECTLY ONTO THE CONTINUOUS TOP PLATE AS THIS MAY CAUSE DAMAGE TO THE CONTINUOUS TOP PLATE.)
14. WORK DOWN ALONG THE LENGTH OF THE CONTINUOUS TOP PLATE DRIVING THE TOP PLATE APPROXIMATELY HALF ONTO THE LIGATURE RESISTANT BRACKET. THEN RETURN AND DRIVE THE CONTINUOUS TOP PLATE THE REMAINDER OF THE WAY IN UNTIL IT IS FULLY SEATED.

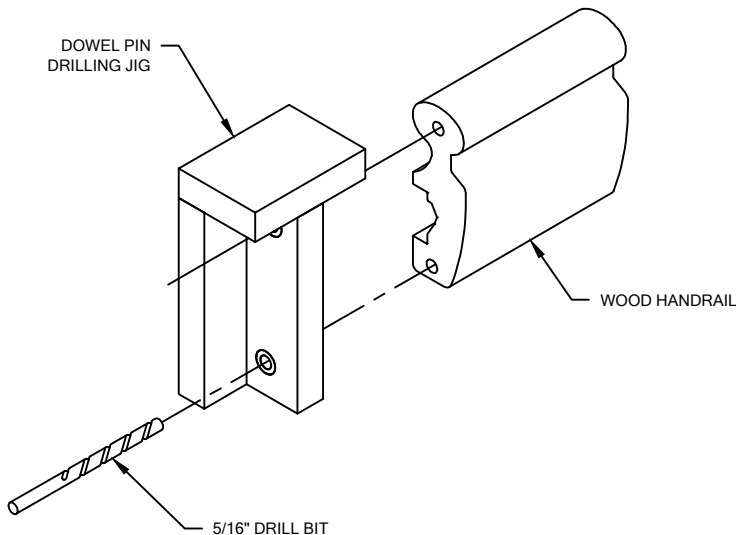

**HANDRAIL SPLICE DRILLING JIG**

1. CUT HANDRAIL TO LENGTH. ALL SPLICE ENDS ARE TO BE CUT SQUARE. EASE FIELD CUT EDGES OF ALL WOOD COMPONENTS AND TOUCH UP SANDED EDGES WITH STAIN MARKER.
2. USE DRILL JIG TO PRE-DRILL CLEARANCE HOLES 7/8" DEEP INTO HANDRAIL USING A 5/16" DRILL BIT (90M039000).  
NOTE: CONTINUALLY CLEAN OUT WOOD CHIPS AS THE PILOT HOLE IS BEING DRILLED.
3. APPLY WOOD GLUE INTO THE HOLES AND CUT SURFACE OF HANDRAIL (TITEBOND IS RECOMMENDED).
4. INSERT DOWELS INTO THE PRE-DRILLED CLEARANCE HOLES.
5. ALIGN DOWELS WITH MATING HANDRAIL CLEARANCE HOLES.
6. CHECK SEAM FOR TIGHT FIT BETWEEN SECTIONS OF HANDRAIL.

**HRW-20CM HANDRAIL**

TYPICAL ASSEMBLY

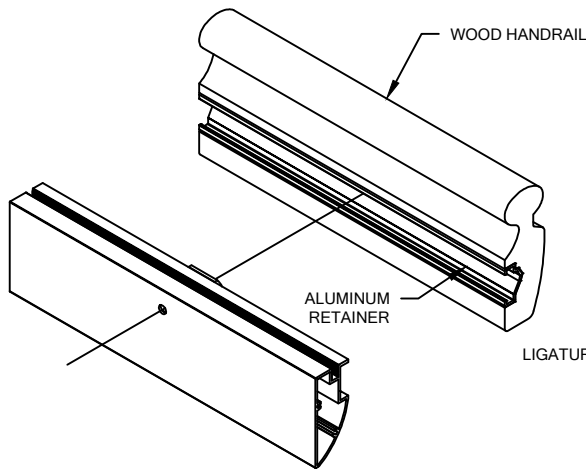

ILLUSTRATION 1

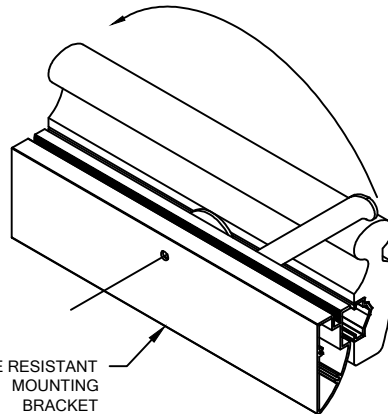

ILLUSTRATION 2

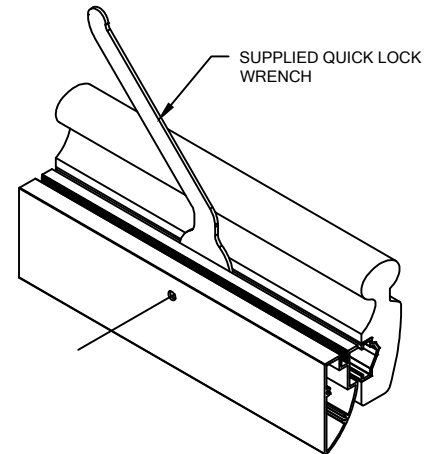
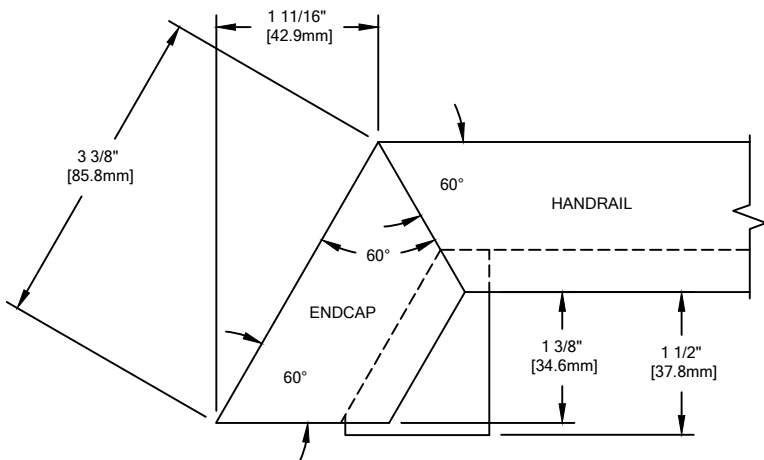

ILLUSTRATION 3



TOP VIEW

END CAP CUTTING INSTRUCTIONS

- 5a. FIELD CUT THE END CAP TO A FACE WIDTH 3 3/8" [85.7mm] LONG WITH 60° CUTS ON BOTH ENDS.
- 5b. GLUE (TITEBOND IS RECOMMENDED) CORNER BLOCK TO THE BACK SIDE OF THE END CAP. ALLOW 1/8" [3.2mm] PROTRUSION OF THE CORNER BLOCK FROM THE END CAP ON THE SIDE THAT MEETS THE WALL.
- 5c. USE TWO 18 GA X 1 1/4" BRAD NAILS TO FURTHER SECURE THE CORNER BLOCK TO THE END CAP ONCE THE GLUE STARTS TO CURE.

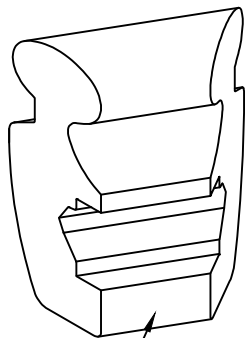

FIELD CUT END CAP

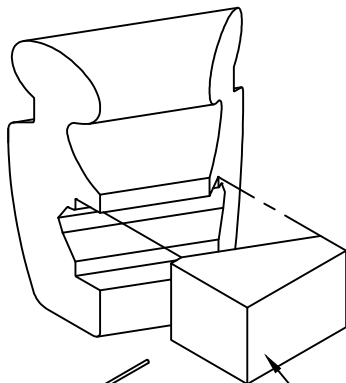

18 GA X 1 1/4" BRAD NAILS (BY OTHERS)

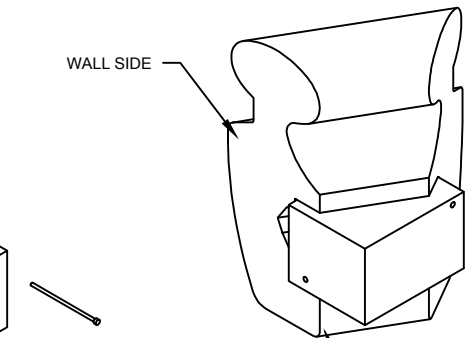

WALL SIDE

ASSEMBLED END CAP (RH SHOWN)