

MODEL "SRJ" AND "SRJW" INSTALLATION INSTRUCTIONS

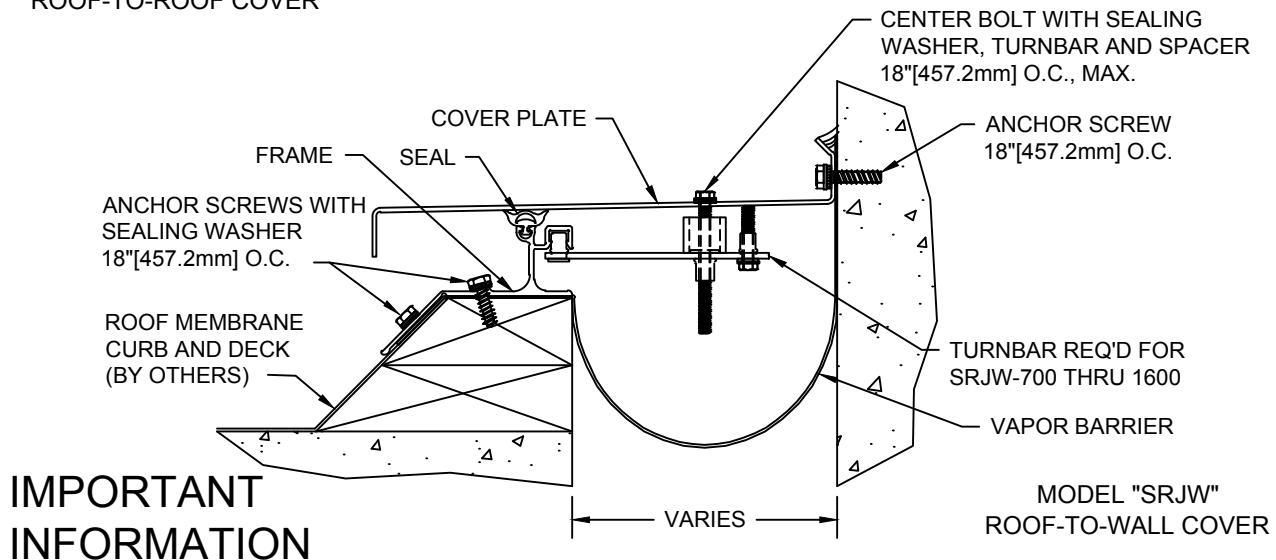
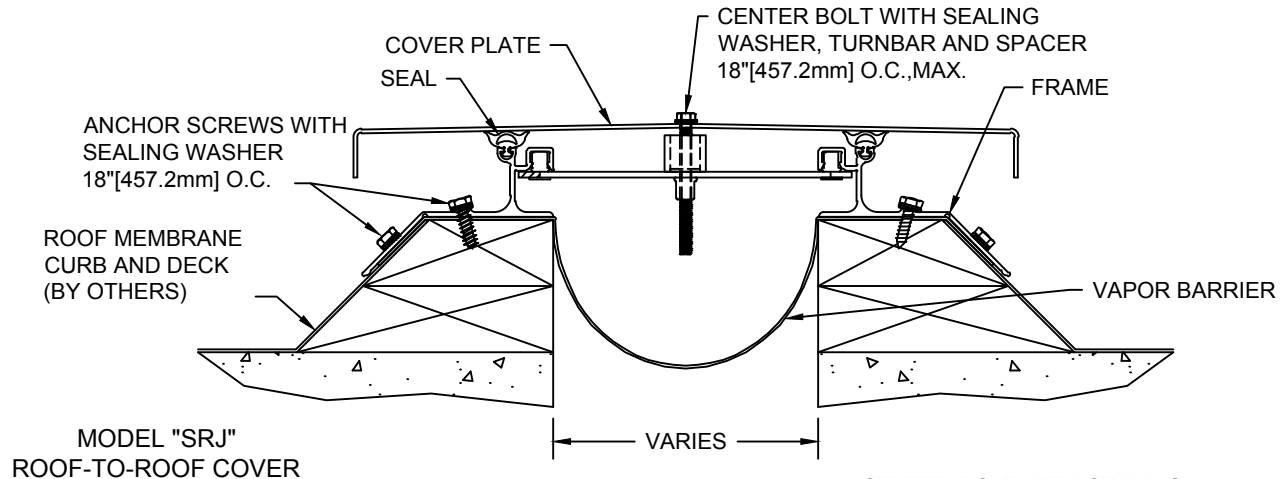

IMPORTANT INFORMATION

Prior to the commencement of installation, all materials **MUST** be inspected for damage. Any damage must be reported to CONSTRUCTION SPECIALTIES, INC., as soon as possible, so that replacement materials may be furnished without delay.

All work must be completed as per Architect's Approved "Shop Drawings", and in accordance with these Installation Instructions. When installation is complete, all materials must be protected from damage until the Architect's FINAL INSPECTION.

All materials should be arranged in the order that they are to be installed. All hardware required for each portion of the work should be placed with the appropriate materials.

Please review all Approved Shop Drawings and this document to familiarize yourself with all the details and components of this assembly.

IMPORTANT:

READ THROUGH ALL INSTRUCTIONS PRIOR TO STARTING INSTALLATION

1/19/16



Construction Specialties™

6696 Route 405 Highway, Muncy PA 17756
(800) 233-8493, Fax (570) 546-5169, www.c-sgroup.com

This document is the property of Construction Specialties, Inc. and contains CONFIDENTIAL PROPRIETARY INFORMATION that is not to be disclosed to third parties and is not to be used without approval in writing from Construction Specialties, Inc.

GENERAL NOTES

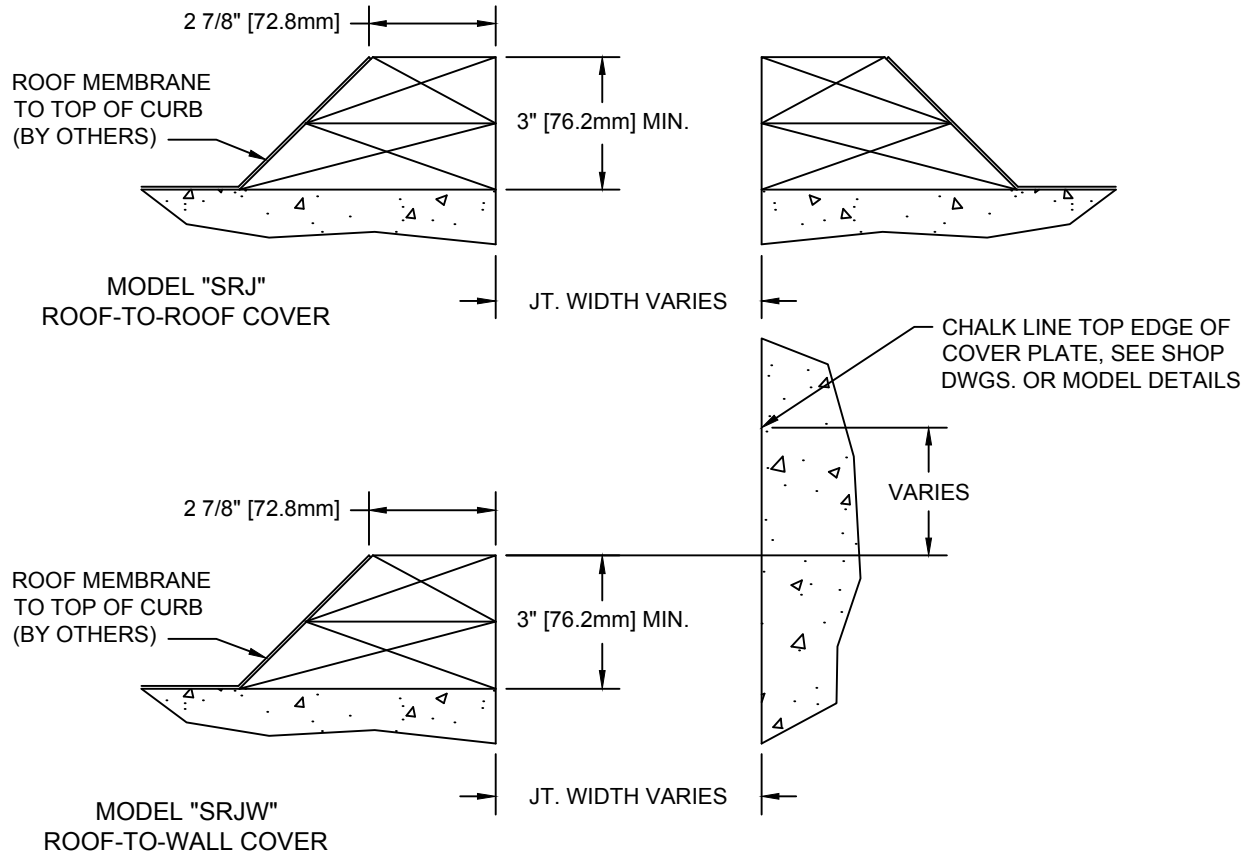

1. The level of water protection provided by the roof joint covers is highly dependent upon proper installation. Read through all of these instructions and review the architectural drawings and approved C/S shop drawings prior to beginning installation.
 2. These installation instructions indicate a common roof curb construction. Other configurations of roof curb and roof deck construction can be accommodated. Refer to the C/S shop drawings for details of alternate construction.
- Note:** The dimension at the top of the curb must be 2 7/8" [72.8mm] +/- 1/8" [3mm] (to the outside of the roof membranes) to allow for proper fit and spacing of the roof cover frames.
3. A given run of roof joint cover may require more than one length of roof cover, the roof cover may turn corners, and/or the configuration of roof cover may change from roof-to-roof to roof-to-wall along the run. If so, factory supplied splice plates and transition components must be installed. Please refer to the C/S shop drawings for details of these conditions. General installation details for these conditions are included in these instructions.
 4. These instructions provide procedures that will help to maximize the water/weather protection provided by the completed installation. Additional steps or variations to some steps may be made as long as the integrity of the installation is maintained.
 5. Before beginning installation, check the field conditions against the architectural drawings and the C/S shop drawings to assure that the roof joint, curb, roof membrane(s) and deck have been prepared as detailed to allow for proper fit and function of the joint cover systems.
 6. When installing adjacent lengths of aluminum extrusion, always leave a 1/16" [1.6mm] minimum gap between pieces for thermal expansion. These gaps may be filled with sealant (by others) as instructed.

STEP 1

INSTALL VAPOR BARRIER

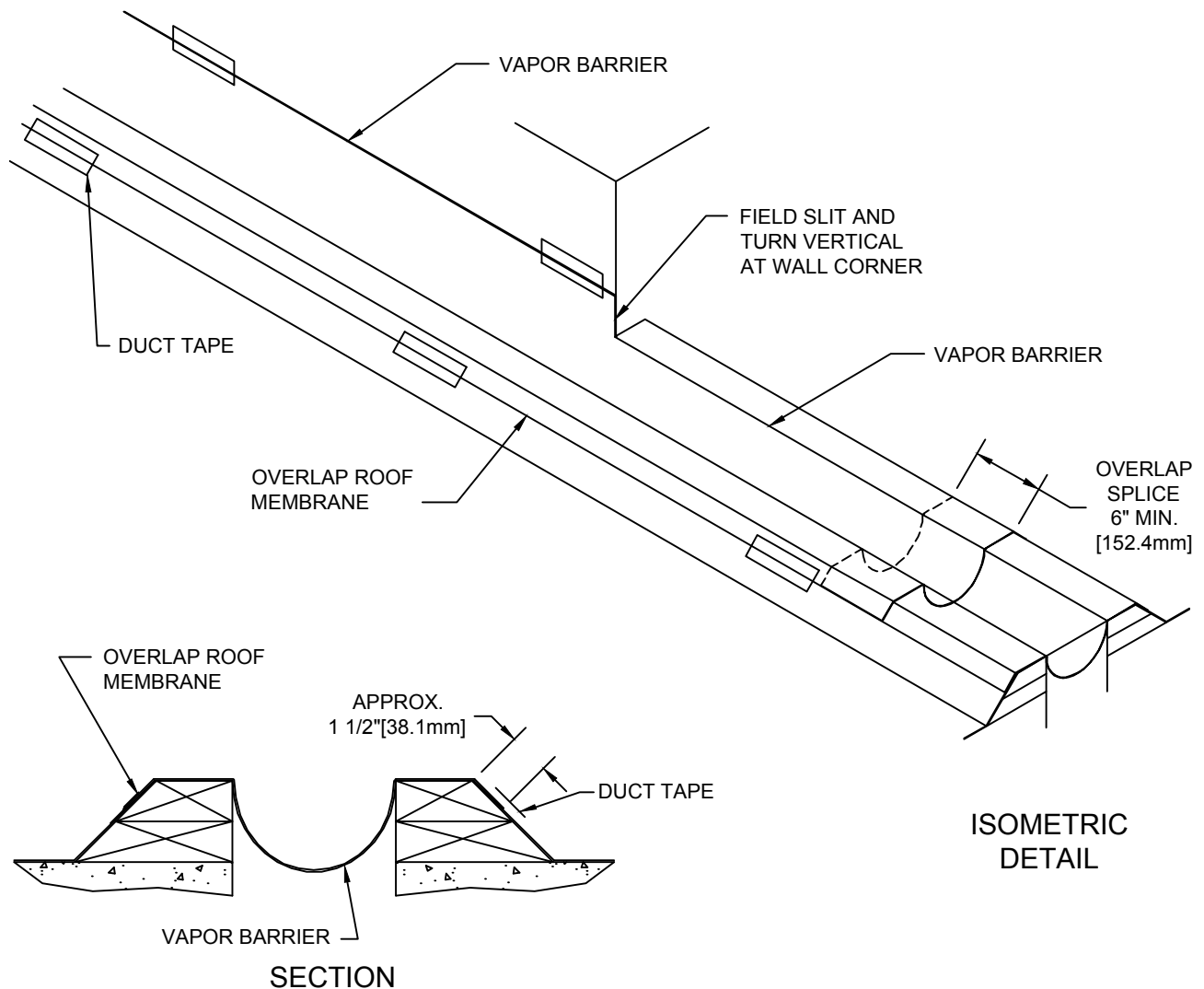

Note: The Vapor Barrier for the "SRJ" and "SRJW" roof joint covers is a reinforced polyethylene sheet and is supplied in rolls at the required width for the nominal joint size.

1.1) Unroll a length of Vapor Barrier along the side of the joint and cut to length as needed. If additional length is needed, refer to the field splicing instructions on page 4.

Note: At end conditions and/or corners (see C/S shop drawings), allow extra length of Vapor Barrier as needed to transition to exterior wall joint covers or to create transitions around the corners.

1.2) Place the Vapor Barrier over the joint and drape the center of the Vapor Barrier slightly down into the joint. The proper drape will be created as the edges are positioned as indicated below.

1.3) At roof-to-roof applications, each edge of the Vapor Barrier is to extend down the sloped face of the curb by approx. 1-1/2" [38.1mm]. The edge of the Vapor Barrier will overlap the roof membrane. At roof-to-wall applications, the roof side edge will extend down the curb as described and the wall side edge will extend up the wall to approx. 3-5/8" [92.1mm] above the top of the curb.

1.4) Use short lengths of duct tape to hold the Vapor Barrier in position until it is anchored.

STEP 1 Continued

FIELD SPLICING VAPOR BARRIER

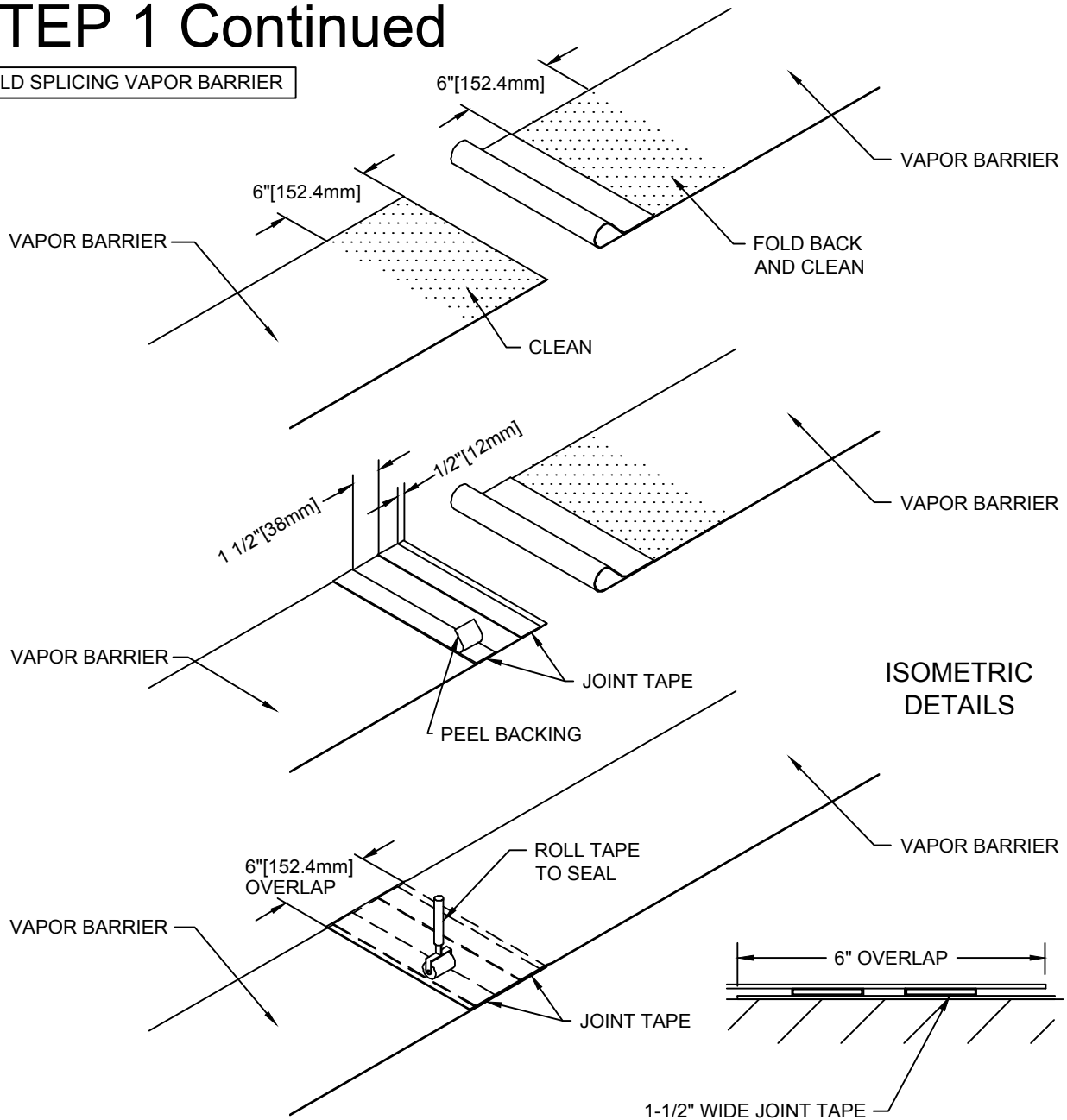

- 1.5) Unroll an additional length of Vapor Barrier along the side of the joint and cut to length.
- 1.6) Fold back the end of the additional length of Vapor Barrier to expose the bottom surface and clean the last 6" [152.4mm] of each piece with Denatured Alcohol.
- 1.7) Apply (2) pieces of the C/S supplied Joint Tape to the end of the first length of Vapor Barrier, at approx. the spacing indicated in details above.
- 1.8) Remove the paper backing from Tape.
- 1.9) Fold the second length of Vapor Barrier back and overlap the first length by approx. 6" [152.4mm] and align the outside edges.
- 1.10) Avoid wrinkles and seat the second piece of Vapor Barrier onto the strips of Joint Tape. Use a seam roller or other round object to roll the Joint Tape to remove air pockets and to fully seal the splice area.

STEP 2

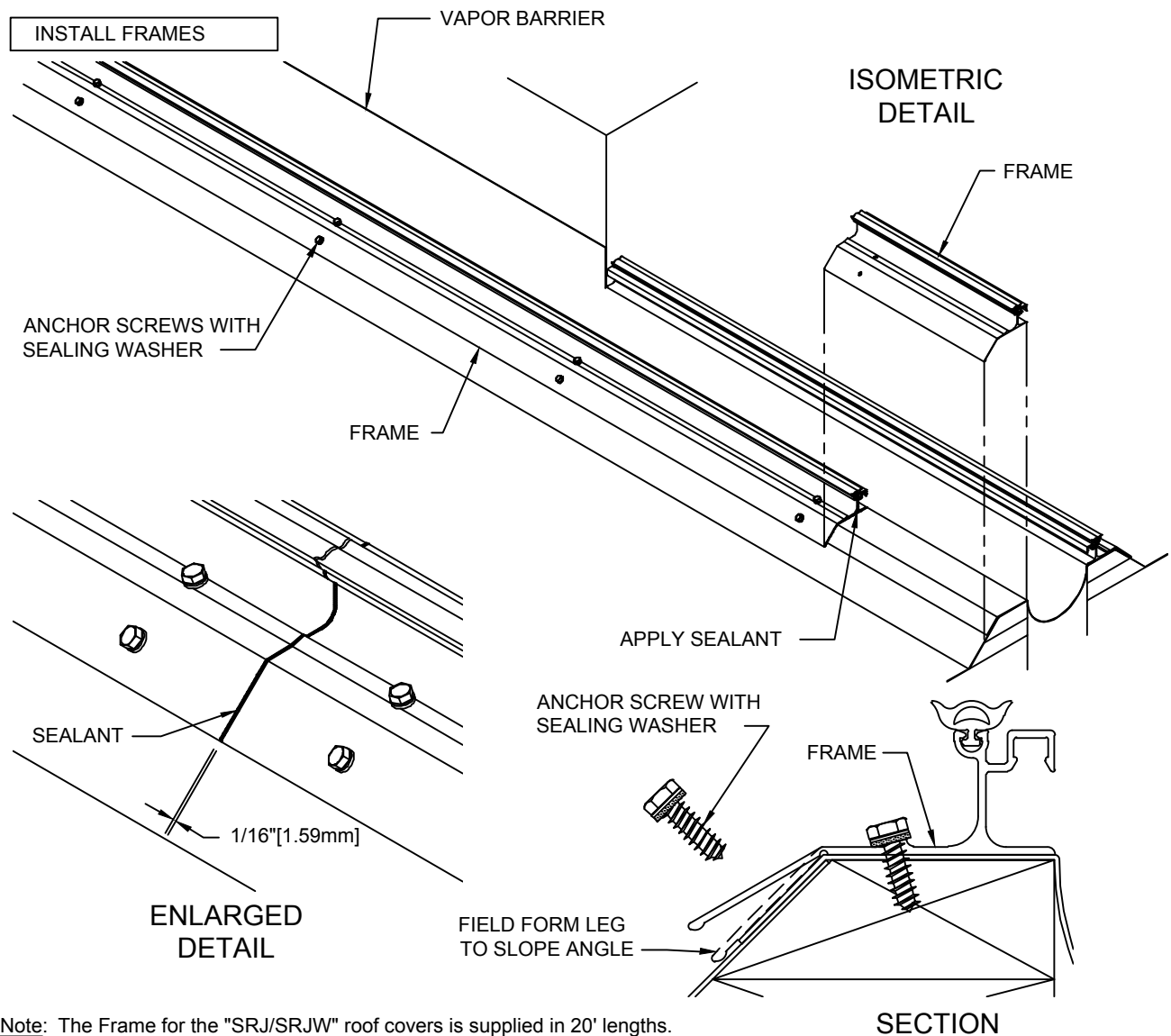

Note: The Frame for the "SRJ/SRJW" roof covers is supplied in 20' lengths.

- 2.1) Select the first length of Frame and cut to length if needed.
- 2.2) Position the Frame on the top of the curb with the inside edge of the Frame aligned with the joint edge. Install the C/S supplied anchor screws (with sealing washers) in the line of anchor holes nearest to the joint.
- 2.3) The leg of the Frame that extends down the slope of the curb is to be field formed to match the slope angle of the curb and to fit tightly to the Vapor Barrier and roof membrane. Bend the leg downward by hand and install the lower row of anchor screws.

Note: The last anchor, near the end of the Frame, is to be no more than 6" [152.4mm] in from the end. If after cutting the Frame to length the end hole is more than 6" [152.4mm] in from the end, drill a new hole (using a 9/32" [7.1mm] bit) at 4" [101.6mm] in from the end of the Frame and install an anchor.

Note: If additional lengths of Frame are required, create a field Frame Splice as follows:

- 2.4) Apply sealant (by others) to the end face of the installed length of Frame.
- 2.5) Position the next length of Frame into the sealant but maintain a 1/16" [1.6mm] gap between frames. Anchor the Frame to the curb as instructed above.
- 2.6) Install all Frames required for the run.

STEP 2 Continued

INSTALL FRAMES AT CORNERS

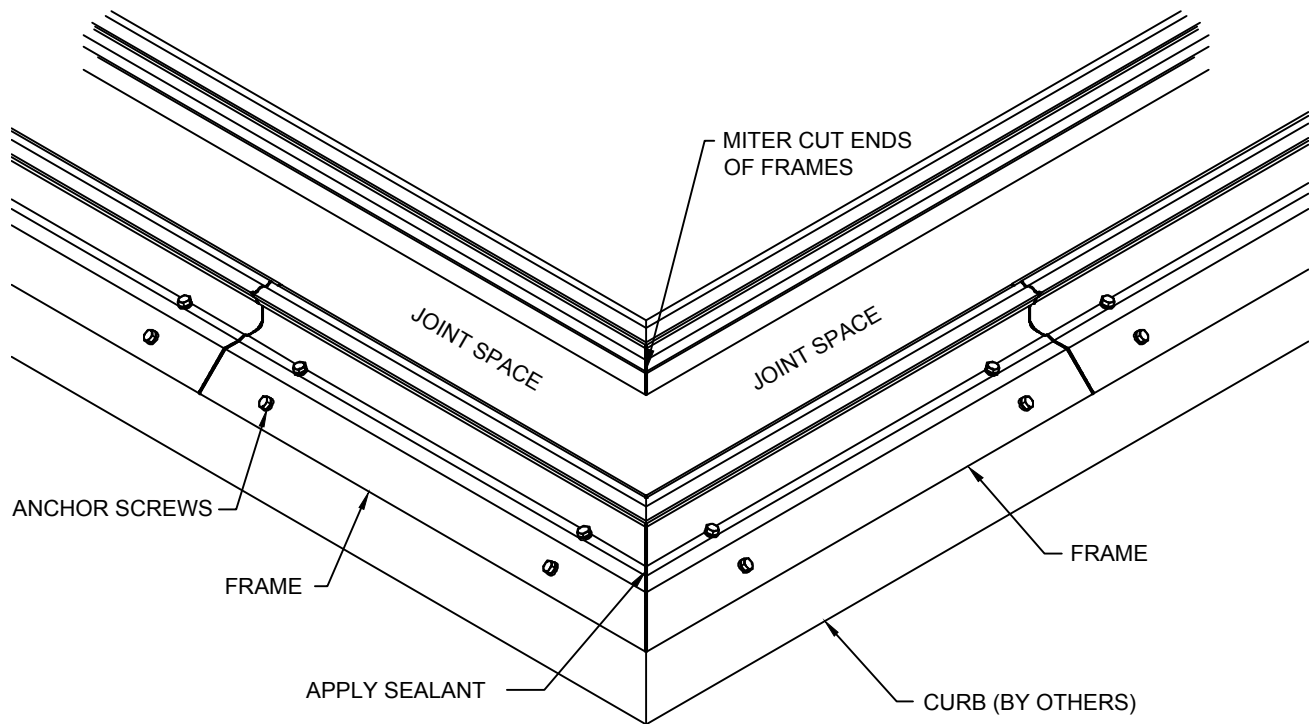

ISOMETRIC DETAIL
AT 90° CORNER

Note: Both the "SRJ" and "SRJW" roof covers may be required to turn corners in the course of a given run. The instructions below describe installation of the Frames, using a 90° roof-to-roof corner as an example.

- 2.7) Measure the length of Frame needed to extend to the corner of the curb.
- 2.8) Miter cut the end of each piece of Frame at the angle needed to create the proper miter.
- 2.9) Position the first piece of Frame and anchor to the curb as instructed. Drill and add new anchor holes as needed.
- 2.10) Apply sealant (by others) to the end face of the installed length of Frame.
- 2.11) Position the next length of Frame (with the opposite miter cut) into the sealant but maintain a 1/16" [1.6mm] gap between Frames. Anchor the Frame to the curb as instructed above.

STEP 3

SPACER INSTALLATION

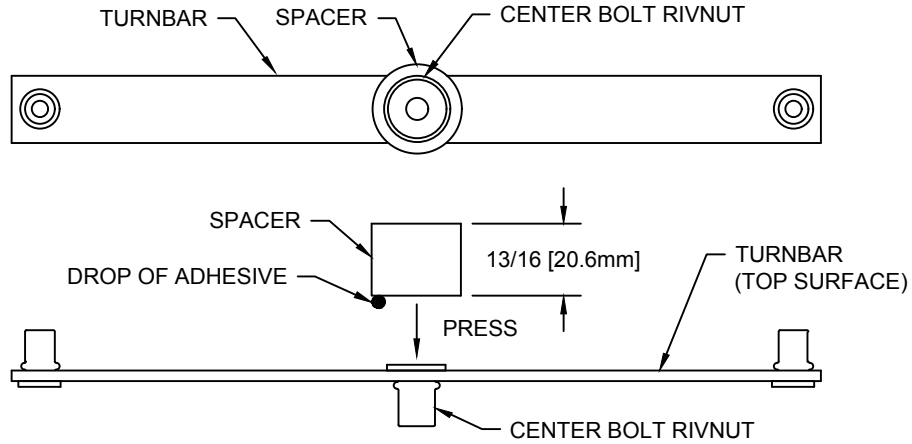

Note: No Turnbar is required for the following model and joint sizes: SRJW-300 - 600 (Proceed to Step 4.4).

A Spacer must be placed between the Turnbar and the underside (or backside) of the Cover Plate. The Spacer is used to prevent excess bowing of the Turnbars when the center bolt is tightened. (Some bowing of the Turnbars is required to apply the holding force on the Cover Plate.)

Spacer Installation:

- 3.1) Place a small drop of "super glue" adhesive (not supplied) onto one end of a Spacer.
- 3.2) Position the end of the Spacer with the adhesive against the top surface of the Turnbar, centered over the flat head portion of the Center Bolt Rivnut. (See detail above.)
- 3.3) Press firmly for a few seconds until the Spacer is bonded to the Turnbar.
- 3.4) Install the Turnbars as instructed.

STEP 4

INSTALL COVER PLATES

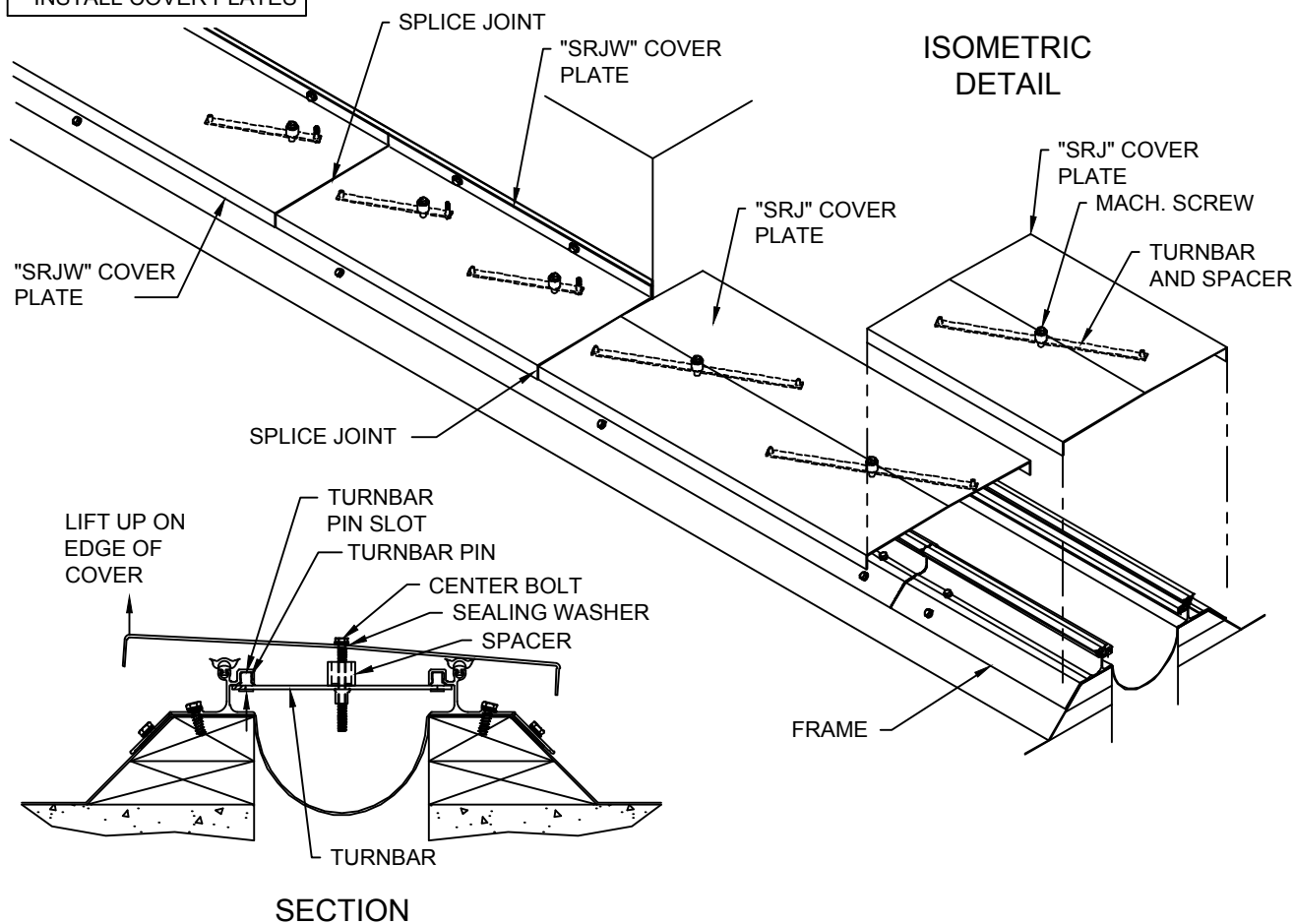

SECTION

Note: The "SRJ/SRJW" Cover Plates are supplied in 10' lengths. Installation of the Cover Plates must be coordinated with installation of factory fabricated Corner Miters and Transition Pieces as indicated on the C/S shop drawings. Position and/or install the factory fabricated components first (refer to Step 5, page 10) and cut the Cover Plates to fit the required dimension between these components. Always leave a 1/16" [1.6mm] minimum gap between adjacent pieces of Cover Plate for thermal expansion.

For "SRJ" Roof-to-Roof Cover Plates:

- 4.1) Establish the required length for the first piece of Cover Plate and cut the piece to length if needed.
- 4.2) Pre-attach the Turnbars and Spacers to the Cover Plate by placing a C/S supplied 5/16-18 machine screw (with sealing washer) through each hole in the Cover Plate. On the underside of the Cover Plate place a Turnbar and Spacer and loosely thread the screw into the center of the Turnbar. **Note:** The Turnbars are to only be threaded onto the screws approx. 1/4" to allow for installation. **Note:** A Turnbar must be no more than 6" [152.4mm] in from each end of the Cover Plate. If after cutting the Cover Plate to length the end hole is beyond 6" [152.4mm], drill a new hole (using a 11/32" [8.73mm] bit) at 4" [101.6mm] in from the end of the Cover Plate, and install a Turnbar (minimum of (2) Turnbars per length).
- 4.3) Position The Cover Plate over the Frames and rotate each Turnbar to the proper orientation as indicated, with each Turnbar angled the same way. The Turnbars must be rotated to position the pin at each end of the Turnbar under the pin slot of each Frame. It may be necessary to lift one edge of the Cover Plate and reach under the Cover Plate to align the pins with the slots. Hold the edge of the Cover Plate up to assure that the pin is in the slot and begin to tighten the center bolt. Repeat for each Turnbar and center bolt. (**Note:** If possible, look under the Cover Plate from the end of the run to see if each Turnbar is properly engaged in the Frames.) Tighten each machine screw until it is snug. **Note:** Remove the protective plastic film from all Cover Plates.

Note: If an additional length or lengths of Cover Plate are required for the run, prepare and install the Cover Plates as instructed above. Maintain a 1/16" [1.6mm] minimum splice joint between lengths.

Cover Plate installation continued on next page.

STEP 4 Continued

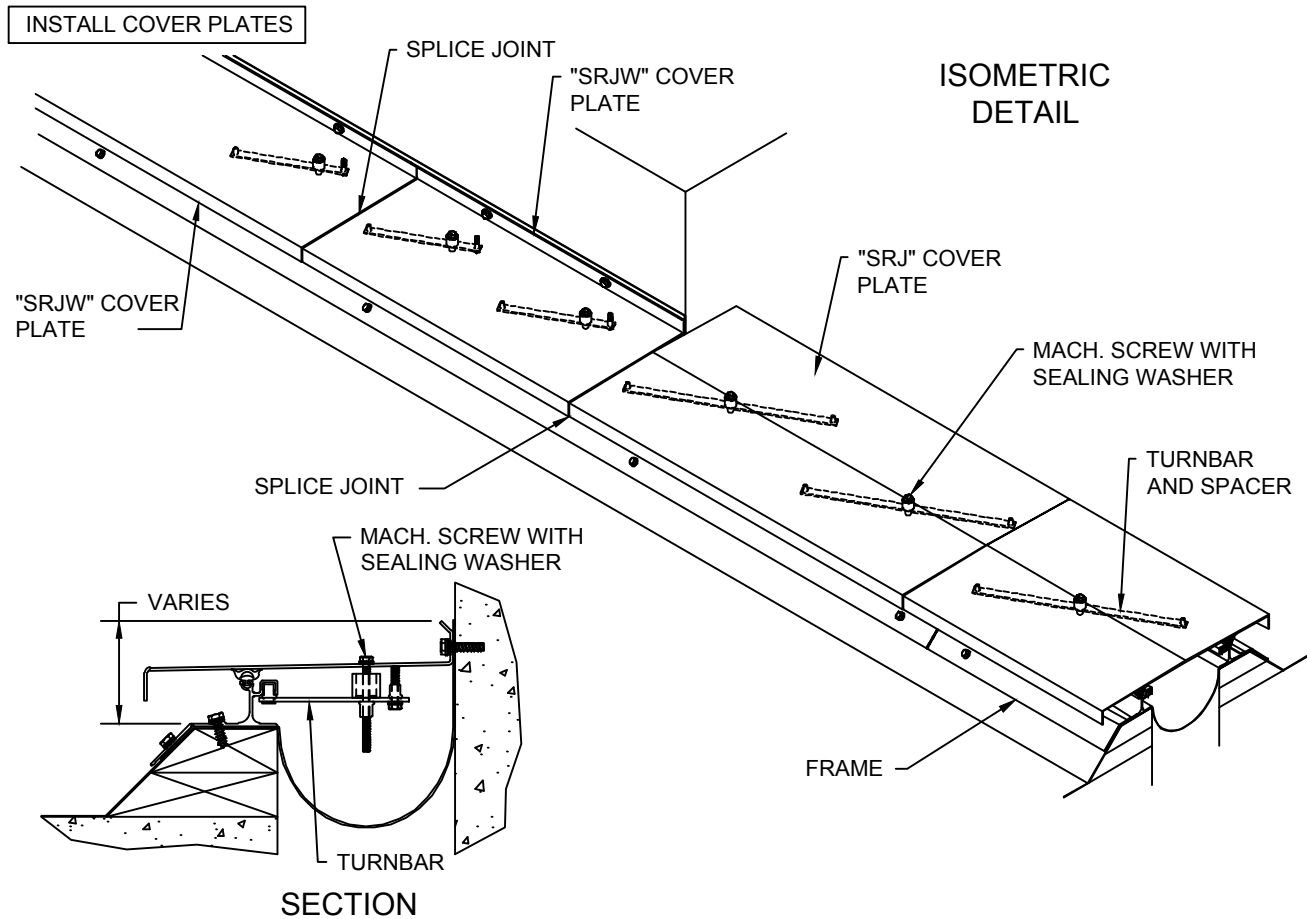

"SRJW" Roof-to-Wall Cover Plates:

Note: No Turnbars are required for the following model and joint sizes: SRJW-400, 500 and 600 (Omit Steps 4.6 and 4.7).

- 4.4) Establish the required length for the first piece of Cover Plate and cut the piece to length if needed. Note: The last wall anchor near the end of the Cover Plate is to be no more than 6" [152.4mm] in from the end. If after cutting the Cover Plate to length the end hole is beyond 6" [152.4mm] from the end, drill a new hole (using a 11/32" [8.73mm] bit) at 4" [101.6mm] in from the end of the Cover Plate.
- 4.5) On the wall opposite the Frame, strike a level chalk line on the face of the wall to locate the anchor position for the top edge of the "SRJW" Cover Plate. This height varies with joint width and model, see C/S shop drawings or model details.
- 4.6) Pre-attach the Turnbars and Spacers to the Cover Plate by placing a C/S supplied 5/16-18 machine screw (with sealing washer) through each hole in the Cover Plate. On the underside of the Cover Plate place a Turnbar and Spacer and loosely thread the screw into the center of the Turnbar.
- 4.7) Position the Cover Plate over the Frame and against the wall. Rotate each Turnbar to the proper orientation as indicated, with each Turnbar angled the same way. The Turnbars must be rotated to position the pin at each end of the Turnbar under the pin slot of each Frame. Tighten each center bolt enough so that the Turnbar pin will no longer drop out of the slot.
- 4.8) Using the holes in the wall leg of the Cover Plate as a template, drill the holes for the C/S supplied wall anchor screws as required using the appropriate drill bit. Clean the holes as needed and anchor the Cover Plate in position.
- 4.9) Tighten each of the center bolts until they are snug to the Cover Plate. Note: Remove the protective plastic film from all Cover Plates.

Note: If an additional length or lengths of Cover Plate are required for the run, prepare and install the Cover Plates as instructed above. Maintain a 1/16" [1.6mm] minimum splice joint between lengths. For the transition from "SRJ" Cover Plate to "SRJW" Cover Plate maintain a 1/16" [1.6mm] minimum gap between plates.

STEP 5

INSTALL CORNER MITER

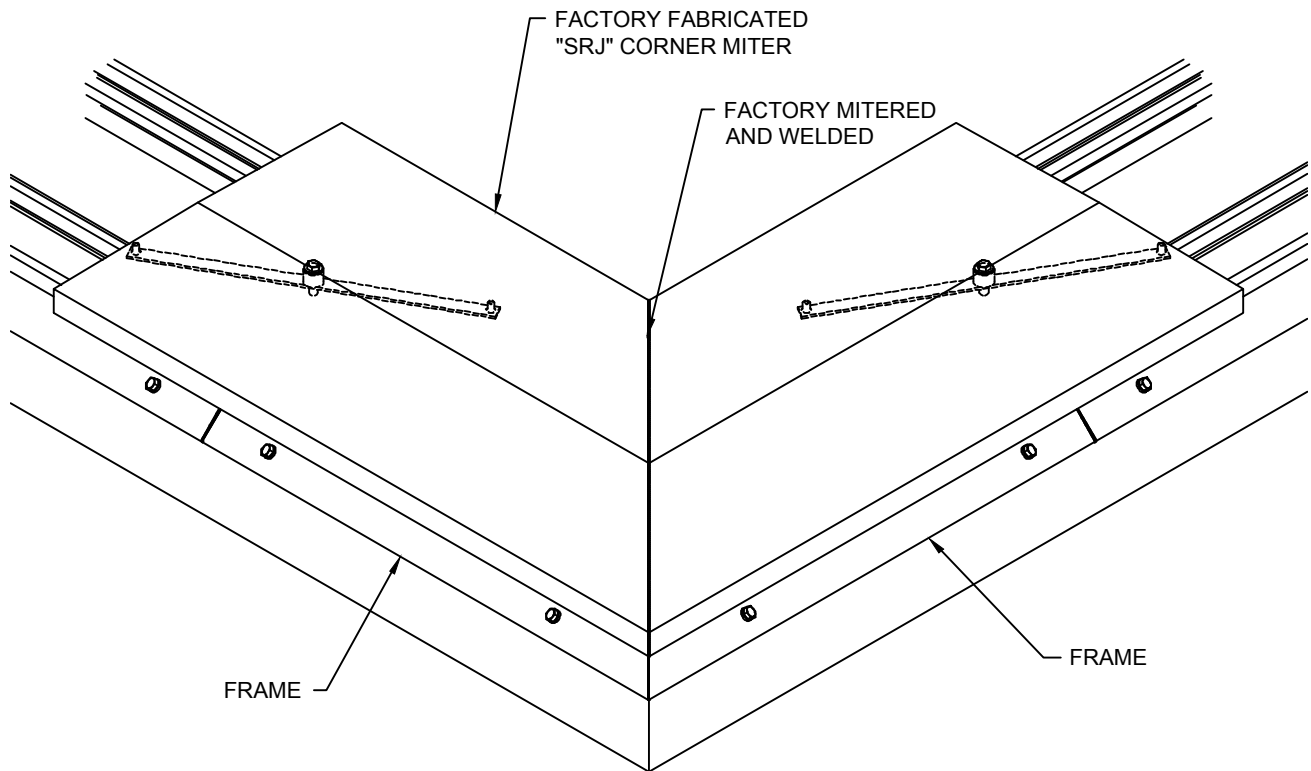

ISOMETRIC DETAIL
AT 90° CORNER

Note: When factory fabricated Corner Miters and/or Transition Pieces are required, as indicated on the C/S shop drawings, these pieces are to be positioned or installed first so that the required length for the standard Cover Plates can be established.

- 5.1) Select the proper factory fabricated Corner Miter for the application as indicated on the C/S shop drawings.
- 5.2) Prepare and install or position the Corner Miter by following the proper "SRJ" and/or "SRJW" Cover Plate installation instructions as provided in Step 4.

STEP 6

INSTALL SPLICE PLATES

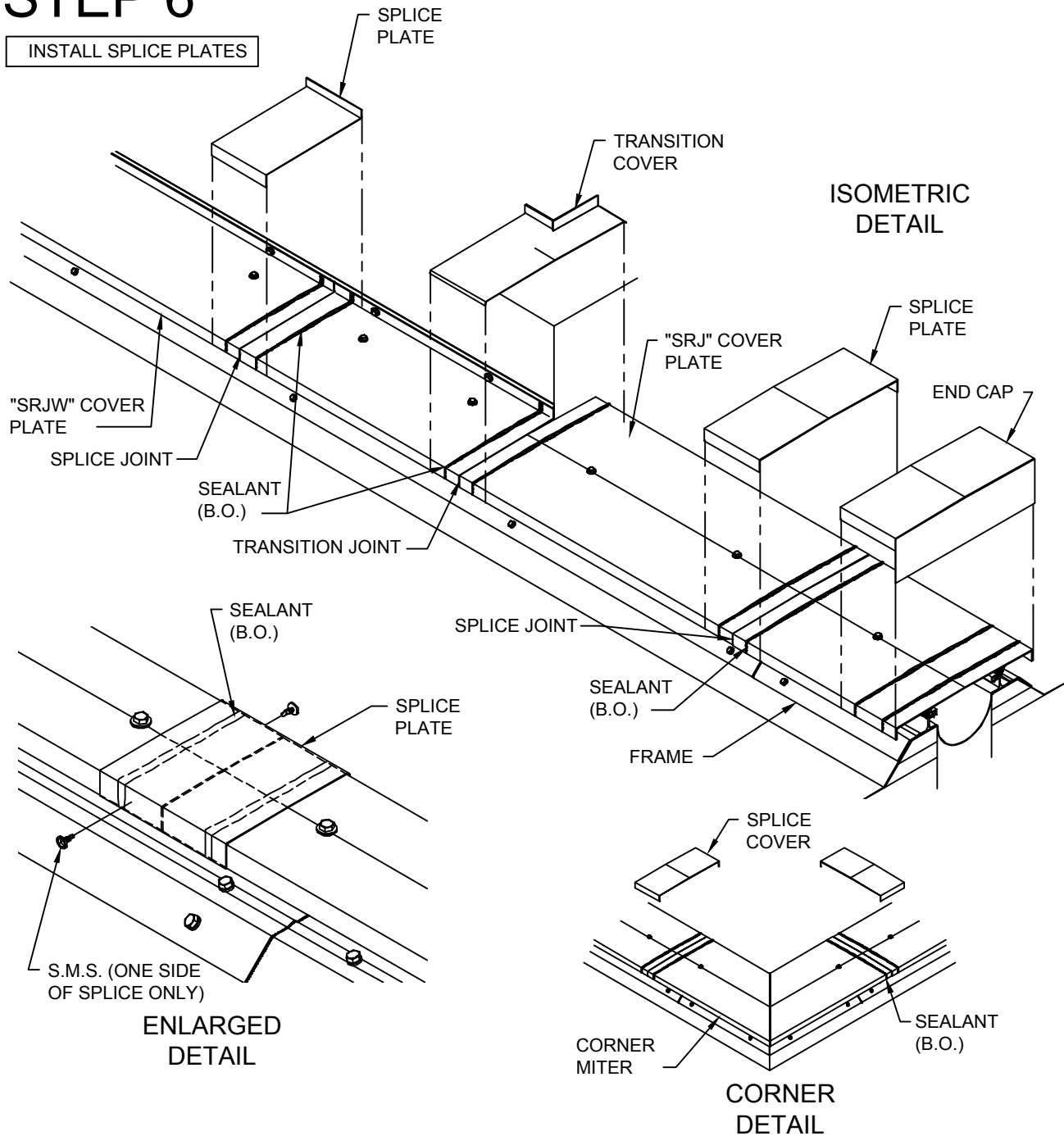

Note: Install factory fabricated Splice Covers at the splice joints between lengths of Cover Plates and between Cover Plates and Corner Miters and Transitions. Install the End Caps and Transition Covers where required.

- 6.1) Place a bead of sealant (by others) across the full width of the Cover Plate, on each side of the splice joint.
- 6.2) Center the Splice Cover over the joint and seat the Splice Cover into the sealant, and fitting over the Cover Plate.
- 6.3) Attach the Splice Cover to the Cover Plate by inserting one self-drilling sheet metal screw into each vertical leg of the Splice Plate (one only at "SRJW"), on one side of the splice joint. **Note:** Do not install screws on both sides of the splice joint as this will hinder thermal expansion movement.
- 6.4) Install the Transition Cover with sealant only. **Note:** The Transition Cover cannot overhang the vertical sides of the Cover Plates due to differential movement that will occur at this location.

STEP 7

COMPLETE INSTALLATION

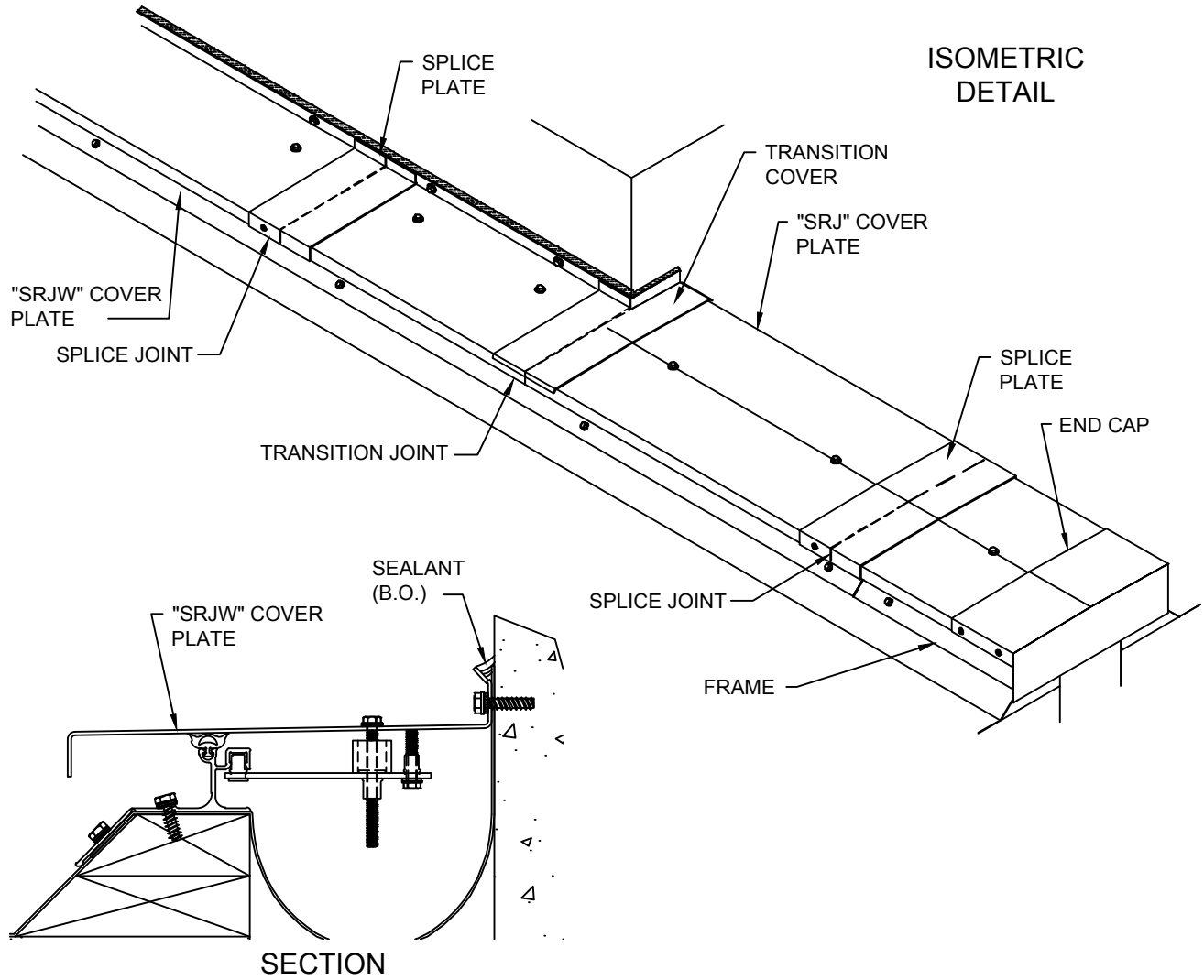

7.1) To complete the installation, apply sealant (by others) along the top edge of all "SRJW" Cover Plates.

7.2) At the "SRJ/SRJW" Transition Cover, apply sealant along the top and vertical edge of the leg that returns along the wall.

Note: Remove the protective plastic film from all Splice Covers, End Caps and Transition Covers if not already done.

Installation is now complete.