

## SM-20MN ODD ANGLE CORNER GUARDS

### PLEASE READ

PLEASE READ THESE INSTRUCTIONS THOROUGHLY PRIOR TO BEGINNING THE SM-20MN CORNER GUARD INSTALLATION!

THIS INSTRUCTION SHEET IS INTENDED TO PROVIDE A SPECIFIC GUIDE TO FOLLOW FOR THE INSTALLATION OF THIS SM-20MN CORNER GUARD. CONTAINED WITHIN IS THE TECHNICAL INFORMATION AND INSTALLATION TECHNIQUES REQUIRED TO COMPLETE AN EFFICIENT, NEAT AND LONG-LASTING INSTALLATION.

INSPECT ALL MATERIALS FOR DAMAGE OR MISSING PARTS. IF YOU DISCOVER DAMAGED OR MISSING MATERIALS, IN THE USA PLEASE NOTIFY THE FACTORY AT (800) 233-8493, AND IN CANADA (888) 895-8955 FOR CUSTOMER SERVICE.

SM-20MN CORNER GUARD MUST BE INSTALLED IN ACCORDANCE WITH THESE INSTRUCTIONS! FAILURE TO FOLLOW THESE INSTRUCTIONS MAY VOID ANY PRODUCT WARRANTIES AND RESULT IN AN UNSUCCESSFUL INSTALLATION. FOR SPECIFIC QUESTIONS REGARDING THE INSTALLATION OF THIS SM-20MN CORNER GUARD PLEASE CALL THE FACTORY IN THE USA AT (800) 233-8493 OR EMAIL [IWPTECHSUPPORT@C-SGROUP.COM](mailto:IWPTECHSUPPORT@C-SGROUP.COM). IN CANADA CALL (888) 895-8955.

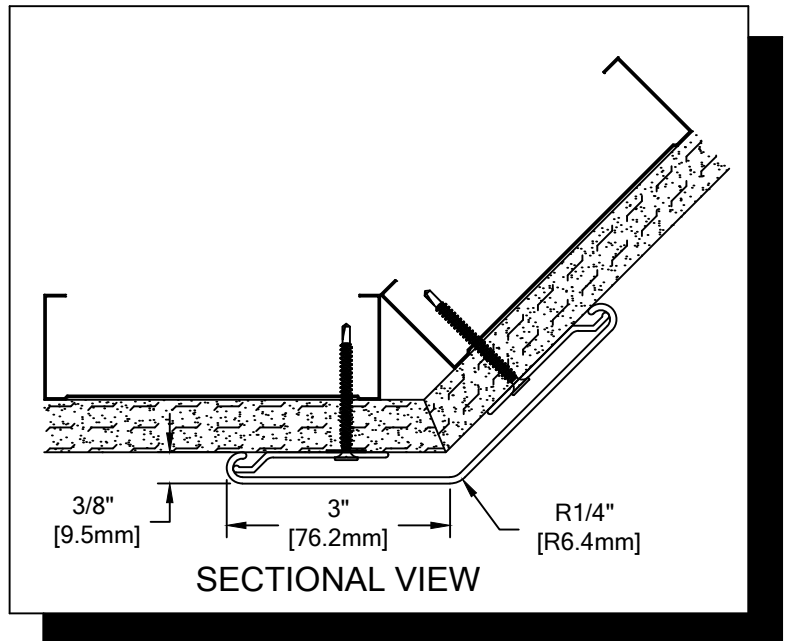

### IMPORTANT NOTES

1. ALL LINEAL MATERIAL TO BE SUPPLIED IN STOCK LENGTHS. ALUMINUM AND ACROVYN IN LENGTHS UP TO 20'0". THIS MATERIAL IS TO BE FIELD CUT USING QUALITY EQUIPMENT TO INSURE THAT ALL CUTS ARE SQUARE. WHEN CUTTING MATERIAL SECTIONS, CS RECOMMENDS USING AN 80-100 TOOTH CARBIDE TIPPED SAW BLADE OR EQUIVALENT, TO MINIMIZE CHIPPING AND MAINTAIN JOINT ALIGNMENT.
2. ALL DIMENSIONS ARE TYPICAL.
3. FOR DRYWALL/PLASTER WALL CONSTRUCTION, IT IS RECOMMENDED FOR FASTENERS TO BE ENGAGED INTO METAL/WOOD STUDS TO MAINTAIN MAXIMUM PULLOUT STRENGTH.
4. MATERIAL MUST REACH 65°F MIN. TO 75°F MAX. 24 HOURS PRIOR TO INSTALLATION. THIS IS ESSENTIAL TO MINIMIZE EXPANSION AND CONTRACTION OF MATERIAL.
5. FASTENERS ARE TO BE STAGGERED BY 2" [50.8mm] TO AVOID INTERFERENCE AND SPALLING OF THE MASONRY WALL.
6. FOR MORE INFORMATION ON SM-20MN CORNER GUARDS SEE OUT WEBSITE AT [www.c-sgroup.com](http://www.c-sgroup.com).

**SM-20MN ODD ANGLE  
CORNER GUARDS**

COMPONENTS & WALL FASTENERS

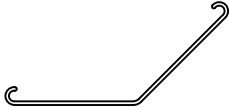

ACROVYN 4000 COVER  
(24U002xxx)  
ACROVYN CHAMELEON COVER  
(24U634xxx)



SM-20MN ALUMINUM RETAINER  
(24A153000)  
SM-20MN REGRIND RETAINER  
(24U037000S)



SM-20MN END CAP  
(24I071xxx)  
CHAMELEON END CAP  
(24I652xxx)

WALL CONDITION	SPECIFIED FASTENER	DRILL DIAMETERS		CS PART NUMBER
		WALL	RETAINER	
STEEL STUD/GYPSUM WALL WOOD STUD/GYPSUM WALL	#6 X 1 5/8" BUGLE HEAD SHEET METAL SCREW	N/A	1/8"	90H079002
CONCRETE/CONCRETE BLOCK	AF-6 PLASTIC ANCHOR #10 X 1 1/2" PHILLIPS PAN HEAD SMS	1/4"	9/32"	90H039004 90H189002
CONCRETE/CONCRETE BLOCK END CAP ATTACHMENT	1/8" BLIND RIVET #8 SAE FLAT WASHER STEEL PLATED	N/A	5/32"	90H111002 90H010003

**SM-20MN ODD ANGLE  
CORNER GUARDS**

LAYOUT VIEW

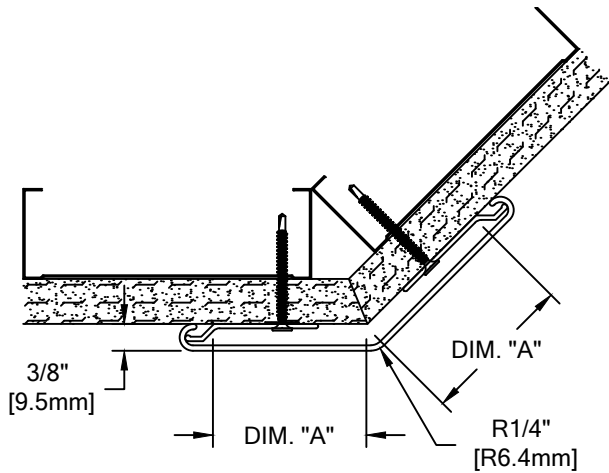

**SM-20MN**

ANGLE	DIMENSION "A"		
	DECIMAL INCHES	FRACTIONAL INCHES	MILLIMETERS
45°	1.657	1 21/32	42.088
50°	1.748	1 3/4	44.399
55°	1.830	1 53/64	46.482
60°	1.900	1 29/32	48.260
65°	1.970	1 31/32	50.038
70°	2.020	2 1/64	51.308
75°	2.052	2 3/64	52.121
80°	2.086	2 5/64	52.984
85°	2.110	2 7/64	53.594
90°	USE STANDARD RETAINER		
95°	2.126	2 1/8	54.000
100°	2.132	2 9/64	54.153
105°	2.154	2 5/32	54.712
110°	2.182	2 3/16	55.423
115°	2.219	2 7/32	56.363
120°	2.241	2 1/4	56.921
125°	2.265	2 17/64	57.531
130°	2.285	2 9/32	58.039
135°	2.300	2 5/16	58.420
140°	2.310	2 5/16	58.674
145°	2.318	2 21/64	58.877
150°	2.325	2 21/64	59.055
155°	2.129	2 1/8	54.083
160°	2.130	2 1/8	54.103

STANDARD DEDUCTIONS

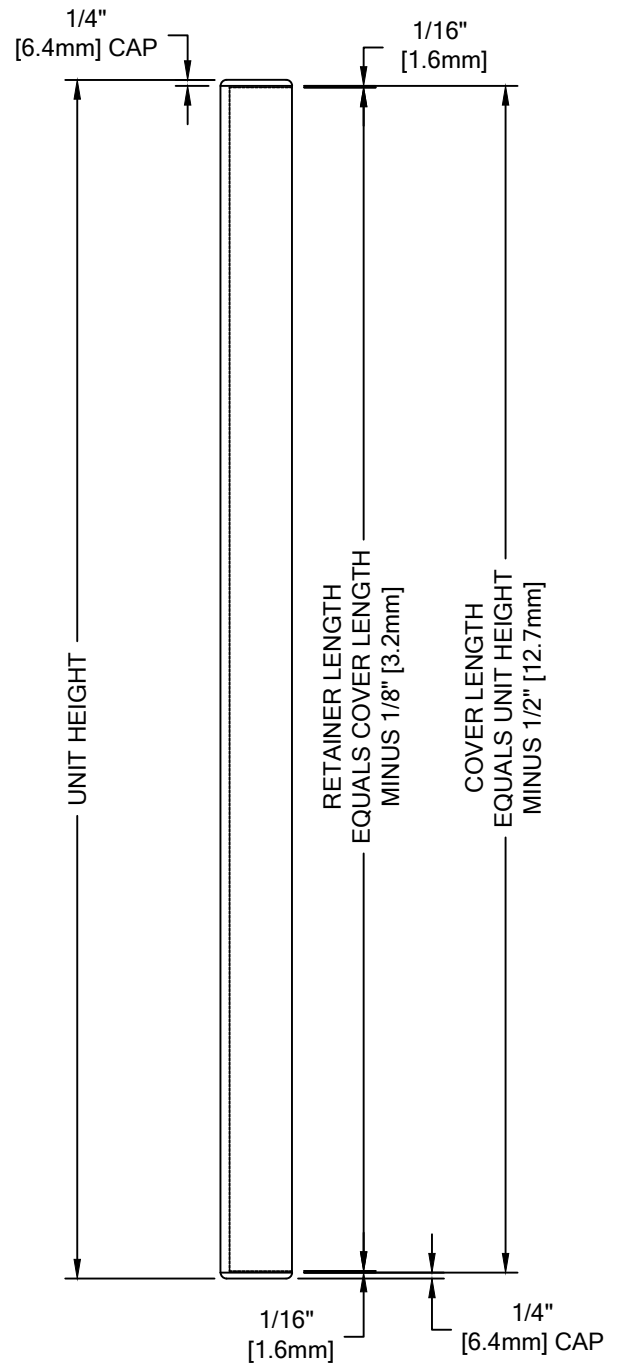

**SM-20MN ODD ANGLE  
CORNER GUARDS**

TYPICAL ASSEMBLY

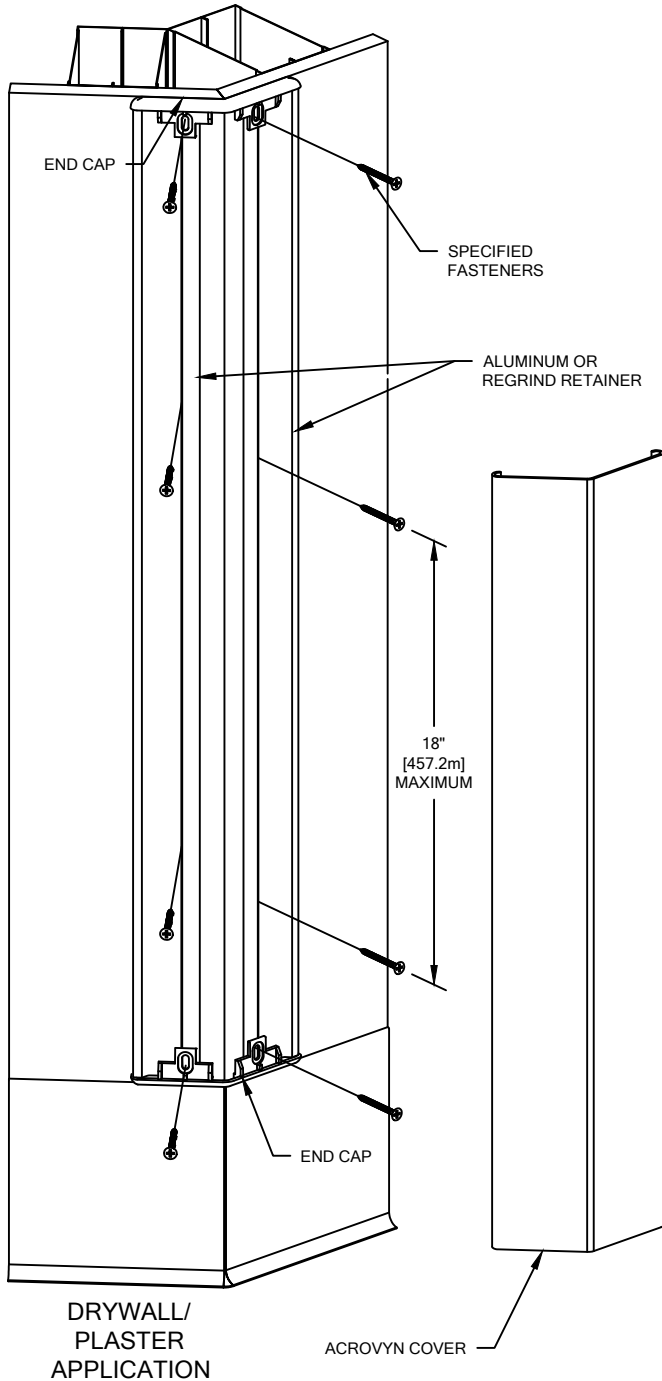

1. LOCATE AND INSTALL CS CORNER GUARDS IN ACCORDANCE WITH ARCHITECTURAL DRAWINGS AND SPECIFICATIONS. WHEN REQUIRED, CS SHOP DRAWINGS SHOULD BE USED IN CONJUNCTION WITH THESE DOCUMENTS.
2. LAY OUT THE WORK TO BE COMPLETED, INCLUDING COMPONENT PARTS, AT EACH LOCATION TO RECEIVE CORNER GUARDS AS INDICATED BY THE CS SHOP DRAWINGS. SPOT CHECK THE MATERIAL FOR ANY DAMAGE INCURRED DURING SHIPPING AND/OR HANDLING AT THE JOB SITE.
3. CUT THE ALUMINUM OR REGRIND RETAINER TO LENGTH USING THE REQUIRED DEDUCTIONS (REFERENCE STANDARD DEDUCTIONS).

**NOTE:** IT IS RECOMMENDED THAT ACROVYN COVER AND RETAINER BE CUT WITH AN 80-100 TOOTH CARBIDE TIPPED SAW BLADE OR EQUIVALENT.

4. INSTALL RETAINER 1/4" [6.4mm] ABOVE COVE BASE OR FINISH FLOOR USING THE REQUIRED FASTENERS AS NOTED ON PAGE 2.
5. INSTALL THE BOTTOM END CAP BY ABUTTING THE CAP WITH THE END OF THE RETAINER, ALLOWING THE FLANGES TO OVERLAP THE END OF THE RETAINER AS SHOWN. SECURE INTO POSITION USING THE SPECIFIED FASTENERS.

**NOTE:** TO AID IN LOCATING THE END CAPS CORRECTLY, CUT A 4" [101.6mm] SECTION OF COVER FROM SCRAP AND SNAP IT ON THE RETAINER. LOCATE THE CAP SO IT ALIGNS FLUSH WITH TOP AND BOTTOM OF THE COVER.

**NOTE:** FOR MASONRY INSTALLATIONS: ATTACH THE END CAPS TO THE RETAINER FIRST, THEN ATTACH THE ASSEMBLED UNIT TO THE SUBSTRATE.

6. REPEAT THE PROCEDURE TO INSTALL THE TOP END CAP.
7. CUT THE ACROVYN COVER TO THE PROPER LENGTH USING THE REQUIRED DEDUCTIONS (REFERENCE STANDARD DEDUCTIONS).
8. FINISH INSTALLATION BY SNAPPING THE ACROVYN COVER ONTO THE RETAINER.

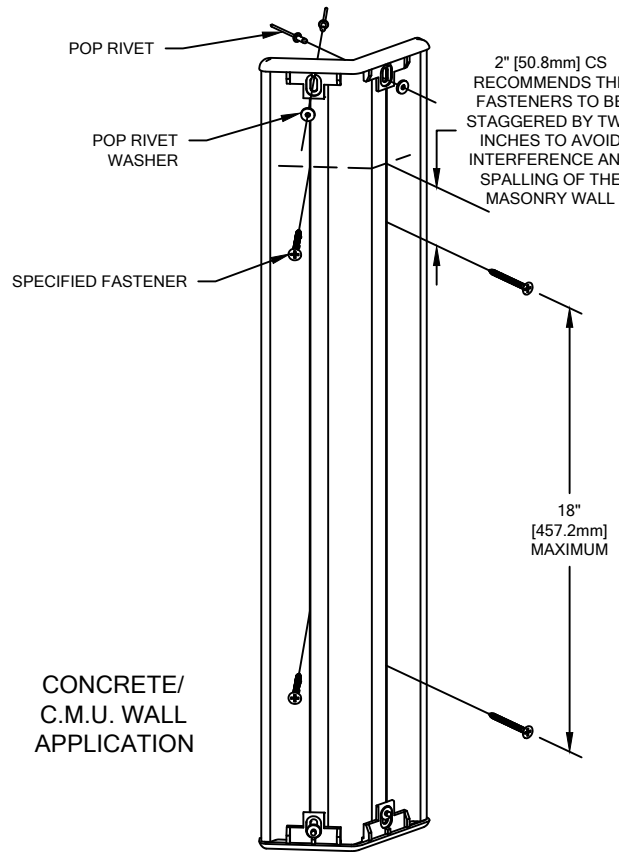

12/06/17