

GTRM-D

TECHNICAL DATA:

Aluminum

- Extrusion – CS uses multiple alloys & tempers which are established to be the most appropriate for the given use of individual parts. Will be one of the following: (6063-T5, T6, T52) (6061-T5, T6, T51) (6105-T5, T6) (6005-T5) (6005A-T5, T61), ASTM B221

Primary Seal

- Dual Durometer 65 Shore A, 90 Shore A, ASTM D2240
- Available in 5 Standard colors

Center Plate

- 3/8" deep recess

Standard Loading

- 500 lbs.

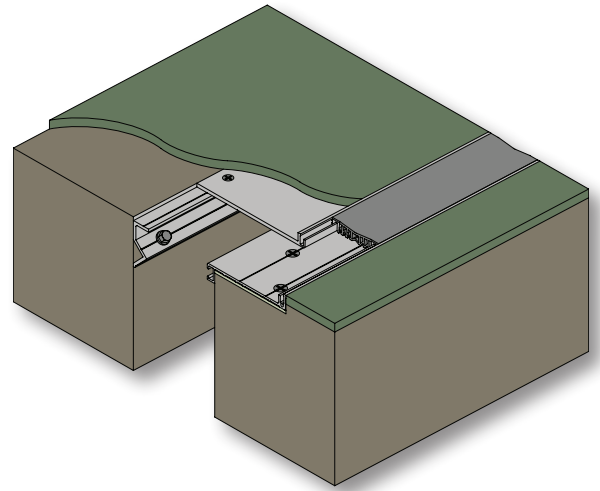

MODEL	JOINT WIDTH	MINIMUM OPENING	MAXIMUM OPENING	EXPOSED SURFACE	BLOCKOUT WIDTH	BLOCKOUT HEIGHT
GTRM-200D	2.00" (51mm)	1.00" (25mm)	3.00" (76mm)	4.25" (108mm)	2.25" (57mm)	0.63" (16mm)
GTRM-300D	3.00" (76mm)	1.50" (38mm)	4.50" (114mm)	6.50" (165mm)	3.50" (89mm)	0.63" (16mm)
GTRM-400D	4.00" (102mm)	2.50" (64mm)	5.50" (140mm)	7.50" (191mm)	3.50" (89mm)	0.63" (16mm)

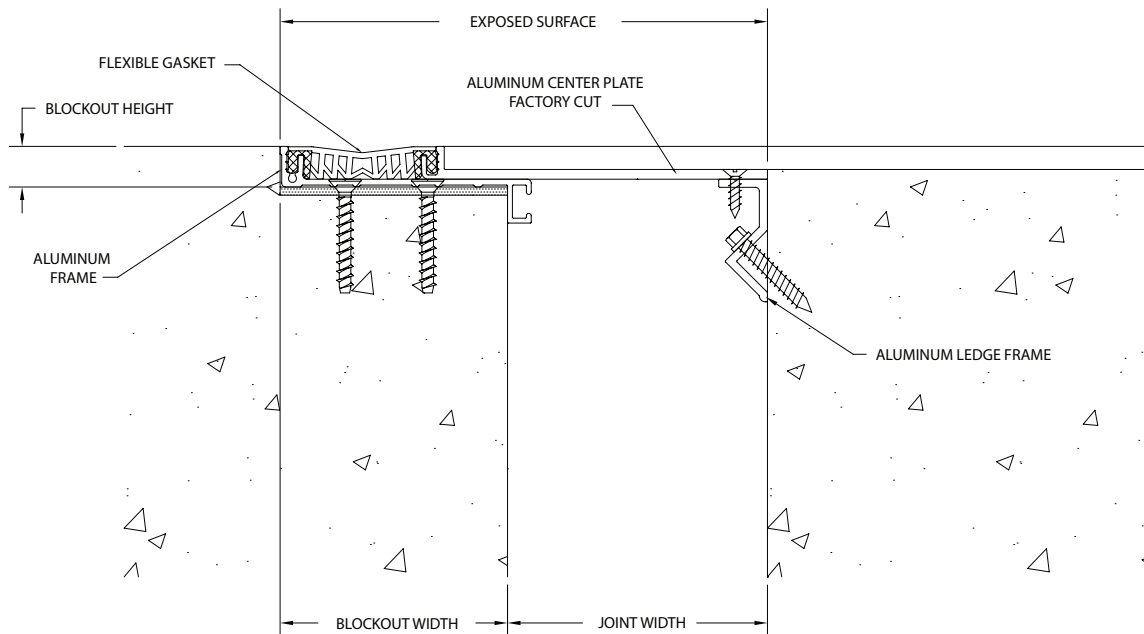

GTRM-D