

HRB-35N HANDRAIL

WITH INTERNATIONAL OFFSET

PLEASE READ

PLEASE READ THESE INSTRUCTIONS THOROUGHLY PRIOR TO BEGINNING THE HRB-35N HANDRAIL INSTALLATION!

THIS INSTRUCTION SHEET IS INTENDED TO PROVIDE A SPECIFIC GUIDE TO FOLLOW FOR THE INSTALLATION OF THIS HRB-35N HANDRAIL. CONTAINED WITHIN IS THE TECHNICAL INFORMATION AND INSTALLATION TECHNIQUES REQUIRED TO COMPLETE AN EFFICIENT, NEAT AND LONG-LASTING INSTALLATION.

INSPECT ALL MATERIALS FOR DAMAGE OR MISSING PARTS. IF YOU DISCOVER DAMAGED OR MISSING MATERIALS, IN THE USA PLEASE NOTIFY THE FACTORY AT (800) 233-8493, AND IN CANADA (888) 895-8955 FOR CUSTOMER SERVICE.

HRB-35N HANDRAIL MUST BE INSTALLED IN ACCORDANCE WITH THESE INSTRUCTIONS! FAILURE TO FOLLOW THESE INSTRUCTIONS MAY VOID ANY PRODUCT WARRANTIES AND RESULT IN AN UNSUCCESSFUL INSTALLATION. FOR SPECIFIC QUESTIONS REGARDING THE INSTALLATION OF THIS HRB-35N HANDRAIL PLEASE CALL THE FACTORY IN THE USA AT (800) 233-8493 OR EMAIL IWPTECHSUPPORT@C-SGROUP.COM. IN CANADA CALL (888) 895-8955.

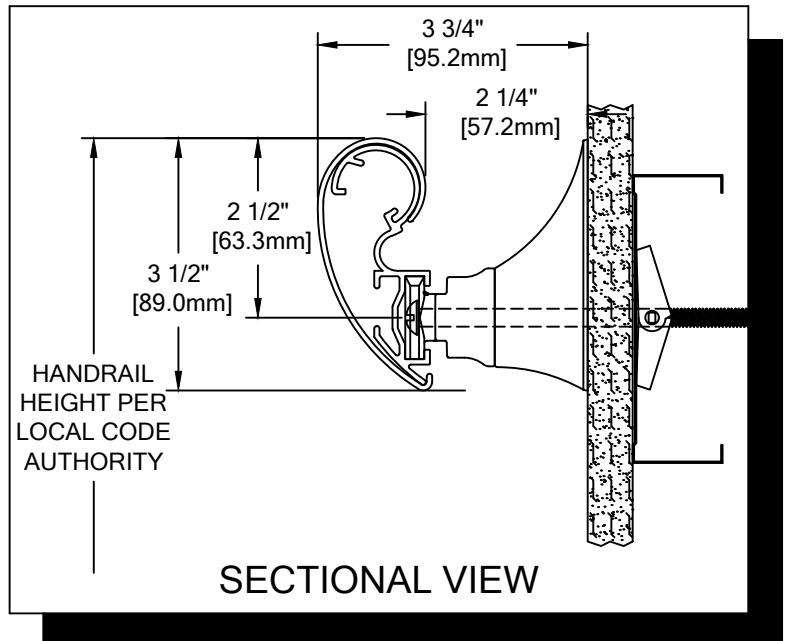

IMPORTANT NOTES

1. ALL LINEAL MATERIAL TO BE SUPPLIED IN STOCK LENGTHS. ALUMINUM AND ACROVYN IN LENGTHS UP TO 20'-0". THIS MATERIAL IS TO BE FIELD CUT USING QUALITY EQUIPMENT TO INSURE THAT ALL CUTS ARE SQUARE. WHEN CUTTING MATERIAL SECTIONS, CS RECOMMENDS USING AN 80-100 TOOTH CARBIDE TIPPED SAW BLADE OR EQUIVALENT, TO MINIMIZE CHIPPING AND MAINTAIN JOINT ALIGNMENT.
2. RADIAL MATERIAL MAY BE SUPPLIED FACTORY FORMED OR IN STRAIGHT LENGTHS FOR FIELD FORMING. CONSULT FACTORY FOR OPTIONS.
3. ALL DIMENSIONS ARE TYPICAL.
4. FOR DRYWALL/PLASTER WALL CONSTRUCTION, IT IS RECOMMENDED FOR FASTENERS TO BE ENGAGED INTO METAL/WOOD STUDS TO MAINTAIN MAXIMUM PULLOUT STRENGTH. IF DURING INSTALLATION YOU ENCOUNTER SPECIAL WALL CONDITIONS THAT DO NOT ALLOW FOR DIRECT ATTACHMENT TO THE STUDS PLEASE CONSULT THE LOCAL AUTHORITY HAVING JURISDICTION.
5. INSTALL OUTSIDE CORNERS FIRST.
6. INSTALL LONGEST RUN OF HANDRAIL FIRST.
7. ALUMINUM RETAINER SPLICE SHOULD NOT EXCEED 4" [101.6mm] DISTANCE FROM A BRACKET.
8. THE DISTANCE BETWEEN AN ACROVYN SPLICE JOINT AND AN ALUMINUM RETAINER SPLICE JOINT SHOULD BE STAGGERED 4" [101.6mm].
9. TANGENT POINTS ON FACTORY FORMED RADIAL MATERIAL WILL BE MARKED APPROXIMATELY AND SHOULD BE CUT TO SUIT FIELD CONDITIONS.
10. MATERIAL MUST REACH 65°F MIN. TO 75°F MAX. 24 HOURS PRIOR TO INSTALLATION. THIS IS ESSENTIAL TO MINIMIZE EXPANSION AND CONTRACTION OF MATERIAL.
11. MAY REQUIRE USE OF FIRE PUTTY WHEN INSTALLED ON FIRE WALL WITH TOGGLE BOLTS. REFERENCE INSTRUCTIONS 24FIREPUTTY FOR FIRE PUTTY INSTALLATION.
12. THIS HANDRAIL REQUIRES A MINIMUM OF 2 MOUNTING BRACKETS PER UNIT. THE MINIMUM END CAP-TO-END CAP HANDRAIL LENGTH IS 15 1/2" [393.7mm].
13. FOR MORE INFORMATION ON HRB-35N HANDRAIL SEE OUR WEBSITE AT www.c-sgroup.com.

HRB-35N HANDRAIL
WITH INTERNATIONAL OFFSET

COMPONENTS & WALL FASTENERS



ACROVYN COVER
(24U802xxx)



ALUMINUM RETAINER
(24A191000)

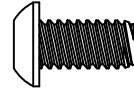

FASTENER #1
1/4-20 X 1/2" BUTTON
SOCKET HEAD SS CAP SCREW
(90H772006)

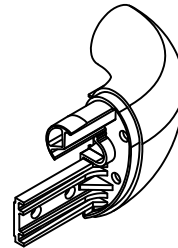

HANDRAIL END CAP
(241848xxx, RH SHOWN)
(241849xxx, LH)

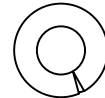

FASTENER #2
1/4" LOCK WASHER
(90H006003)

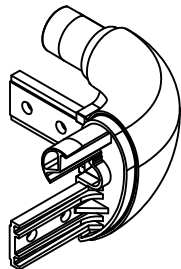

HANDRAIL OUTSIDE
CORNER ASSEMBLY



EXTENDED QUICKLOCK
BRACKET
(241098108)



MOUNTING BRACKET
(241820xxx)

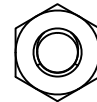

FASTENER #3
1/4-20 HEX NUT
(90H010001)

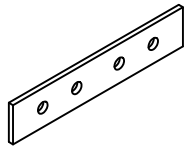

RETAINER SPLICE BAR
(241976000)



OPTIONAL
VERTICAL ACCENT
(241846xxx)

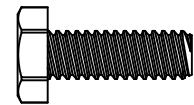

FASTENER #4
1/4-20 X 3/4"
HEX HEAD SS MACHINE SCREW
(90H008006)

WALL CONDITION	SPECIFIED FASTENER	DRILL DIAMETERS		CS PART NUMBER
		WALL	RETAINER	
STEEL STUD/GYPSUM WALL	1/4-20 X 6" ROUND HEAD BOLT WITH TOGGLE 1/4" LOCK WASHER	3/4"	N/A	90H049002 90H006003
CONCRETE/CONCRETE BLOCK	#14 X 6" PHILLIPS SS RD HD ALL-PURPOSE SCREW	3/16"	N/A	90H339006
WOOD STUD/GYPSUM WALL	#14 X 6" PHILLIPS SS RD HD ALL-PURPOSE SCREW	1/8"	N/A	90H339006

HRB-35N HANDRAIL
WITH INTERNATIONAL OFFSET

LAYOUT VIEW

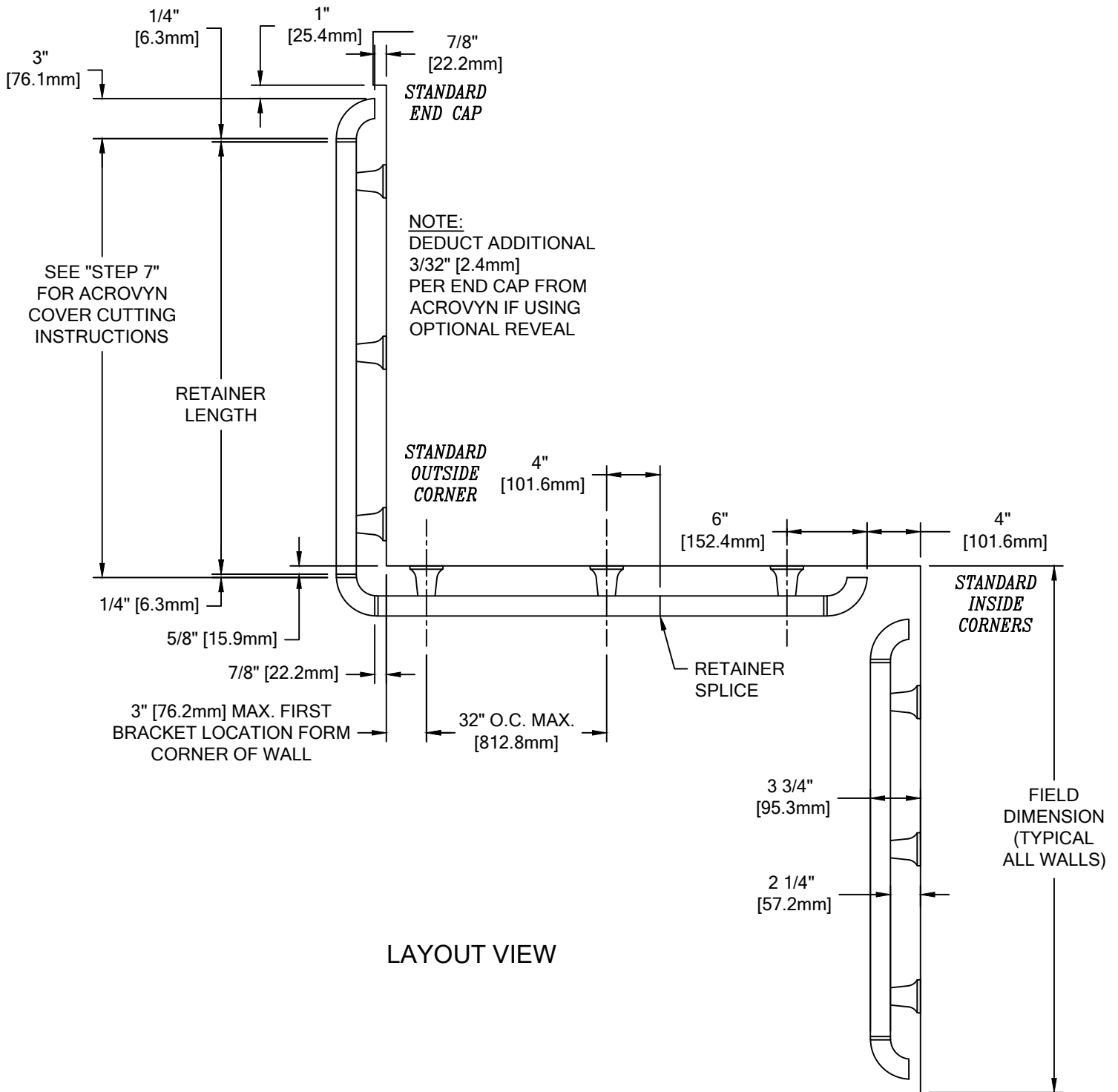

HRB-35N HANDRAIL
WITH INTERNATIONAL OFFSET

TYPICAL ASSEMBLY

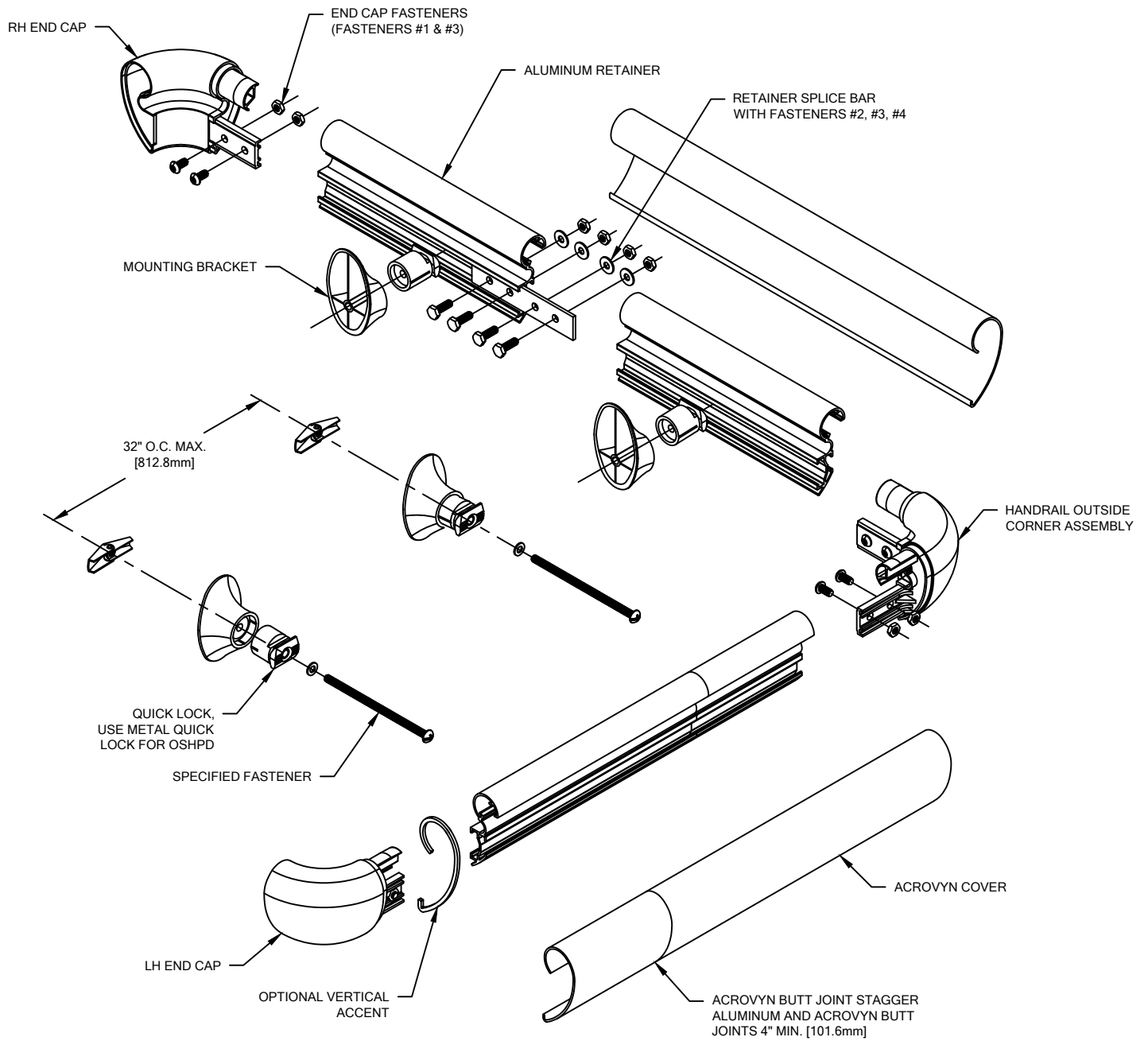

**HRB-35N HANDRAIL
WITH INTERNATIONAL OFFSET**

NOTE: INSTALLATION OF LINEAL OR RADIAL HRB-35N HANDRAIL SHOULD BE DONE IN ACCORDANCE WITH THE FOLLOWING INSTRUCTIONS.

1. ESTABLISH HANDRAIL HEIGHT ABOVE FINISH FLOOR. DEDUCT 2 1/2" [63.3mm] AND SNAP A CHALK LINE AT THAT HEIGHT. THIS MARKS THE LOCATION OF THE FASTENERS FOR THE HANDRAIL BRACKETS.
2. DETERMINE WALL FASTENER LOCATIONS BY USING THE REQUIRED DEDUCTIONS (SEE LAYOUT VIEW). DRILL CLEARANCE HOLES FOR SPECIFIED WALL FASTENERS. REFERENCE CHART ON PAGE 2 FOR CORRECT DRILL DIAMETERS.
3. PLACE A QUICK LOCK INTO EACH MOUNTING BRACKET. USING THE APPROPRIATE FASTENERS, ATTACH THE BRACKET ASSEMBLIES TO THE WALL AT THE PRE-DRILLED LOCATIONS. SEE ILLUSTRATION 1. IF INSTALLING OPTIONAL LIGATURE RESISTANT BRACKET ENCLOSURE, SEE ILLUSTRATION 8. IF USING OSHPD HARDWARE SEE SECTIONAL VIEW ON PAGE 5.

NOTE: IF YOUR ORDER IS A CUT-TO-SIZE JOB, GO TO STEP 5.

NOTE: IF YOUR ORDER IS A PRE-ASSEMBLED JOB, PERFORM STEP 5.

4. CUT THE CONTINUOUS ALUMINUM RETAINER TO LENGTH USING THE REQUIRED DEDUCTIONS AS NOTED (SEE LAYOUT VIEW).

NOTE: IT IS RECOMMENDED THAT THE ACROVYN COVERS AND ALUMINUM RETAINER BE CUT WITH AN 80-100 TOOTH CARBIDE TIPPED SAW BLADE OR EQUIVALENT.

OPTIONAL: THE END CAPS AND COVERS MAY BE INSTALLED ONTO THE RETAINER FIRST, AND THE ASSEMBLY PLACED ONTO THE BRACKETS AS A COMPLETE UNIT AND THEN LOCKED INTO PLACE.

5. PLACE THE RETAINER ON THE MOUNTING BRACKETS SO THAT THE HEAD OF EACH QUICK LOCK INSERTS INTO THE CHANNEL ON THE BACK OF THE RETAINER. USING THE WRENCH PROVIDED, TWIST EACH LOCK 90° TO SECURE THE MOUNTING BRACKET INTO PLACE. SEE ILLUSTRATION 1 THROUGH 4. USE A LEVEL TO ENSURE RETAINER IS LEVEL.

NOTE: WHEN FIELD FORMING RADIUS HANDRAIL, BE SURE TO APPLY NEEDED PRESSURE FROM BRACKET TO BRACKET.

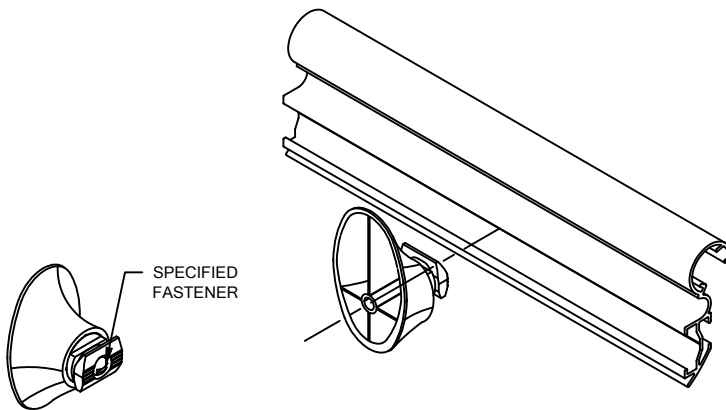

ILLUSTRATION 1

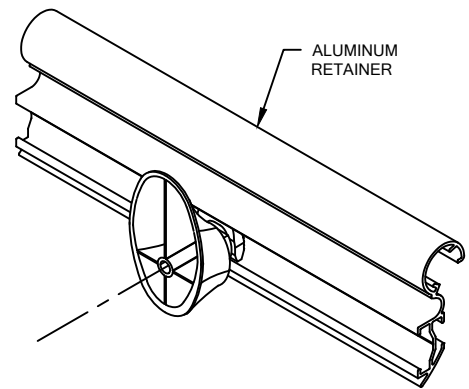

ILLUSTRATION 2

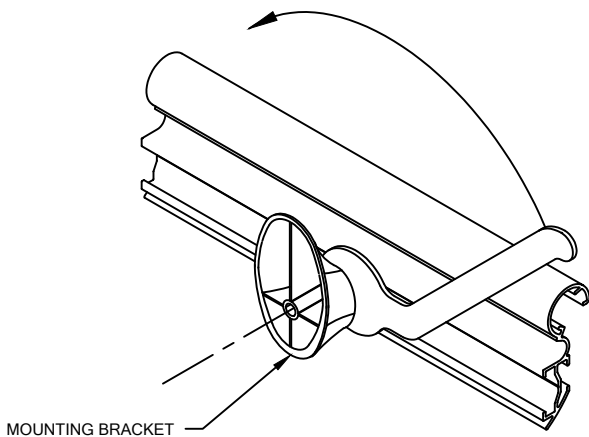

ILLUSTRATION 3

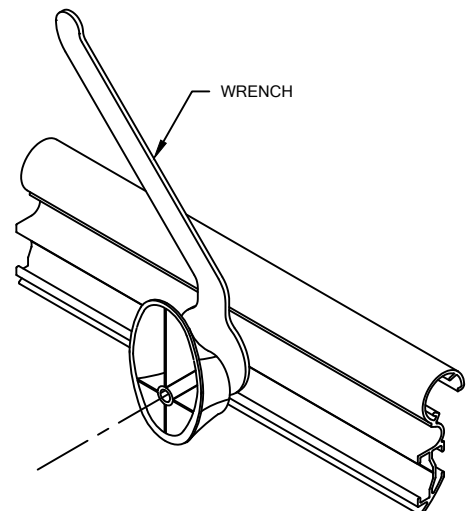

ILLUSTRATION 4

HRB-35N HANDRAIL
WITH INTERNATIONAL OFFSET

- ATTACH END CAPS/OUTSIDE CORNER ASSEMBLIES BY SLIDING THE END CAP/OUTSIDE CORNER ONTO THE END OF THE RETAINER AND SECURING INTO POSITION USING ONE (1) END CAP LOCK AT EACH END CAP AND TWO (2) AT EACH OUTSIDE CORNER. USING AN ALLEN WRENCH, TWIST EACH LOCK 90° TO SECURE THE END CAP INTO PLACE. ONCE END CAPS ARE LOCKED, SECURE INTO POSITION USING ONE (1) 1/2" WAFER HEAD TEK SCREW AT EACH END CAP AND TWO (2) AT EACH OUTSIDE CORNER. SEE ILLUSTRATIONS 5 THROUGH 7.

NOTE: TO AID IN LOCATING THE END CAPS CORRECTLY, CUT A 4" [101.6mm] SECTION OF COVER FROM SCRAP AND SNAP IT ON THE RETAINER. LOCATE THE CAP SO IT ALIGNS FLUSH WITH THE TOP AND BOTTOM OF THE COVER.

- CUT THE ACRYVYN COVERS TO THE PROPER LENGTH. THE COVER LENGTH IS DETERMINED BY MEASURING THE DISTANCE BETWEEN THE INSTALLED END CAPS AND/OR OUTSIDE CORNER ASSEMBLIES.

NOTE: IT IS RECOMMENDED THAT THE ACRYVYN COVERS BE CUT SLIGHTLY LONGER (1/32" UP TO 5'-0", 1/16" OVER 5'-0") THAN THE MEASURED DISTANCE. THIS ADDITIONAL LENGTH WILL PROVIDE FOR A TIGHTER COVER-TO-END CAP FIT.

- ALIGN THE TOP OF THE ACRYVYN COVER WITH THE TOP OF THE ALUMINUM RETAINER AND SNAP THE COVER ONTO THE RETAINER.

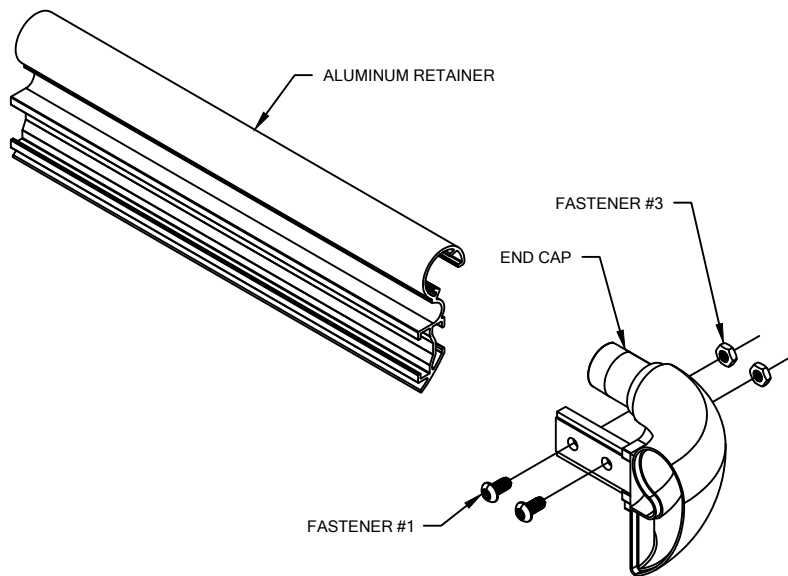

ILLUSTRATION 5

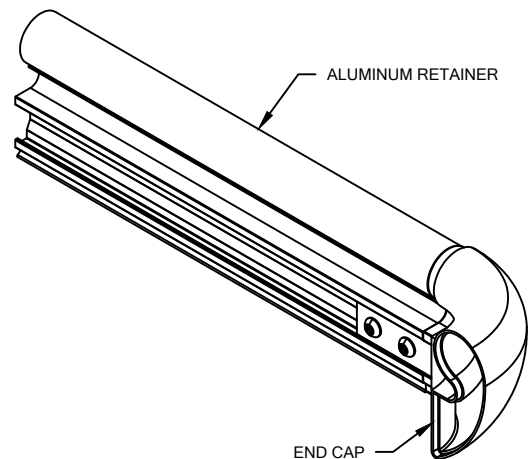

ILLUSTRATION 6

END CAP ATTACHMENT

ATTACH END CAPS/OUTSIDE CORNERS TO THE RETAINER BY LOOSELY THREADING TWO (2) 1/4-20 X 1/2" BUTTON SOCKET HEAD CAP SCREWS THROUGH THE BACKSIDE OF THE FLANGE OF EACH END CAP (FOUR (4) PER CORNER ASSEMBLY) INTO THEIR RESPECTIVE NUTS ON THE RETAINER SIDE OF THE FLANGE. SLIDE THE FLANGE INTO THE RECEIVER CHANNEL OF THE ALUMINUM RETAINER AND TIGHTEN THE BUTTON SOCKET HEAD CAP SCREWS FOR A SECURE FIT.