

COLOR: CORNER GUARD: COLOR TO BE SELECTED FROM ONE OF CS STANDARD COLORS.	UNITS REQ'D	ANGLE	CEILING HEIGHT	RETAINER LENGTH	COVER LENGTH	BASE HEIGHT
---	-------------	-------	----------------	-----------------	--------------	-------------

**NOTES:**

- UNITS TO BE FURNISHED IN LENGTHS TO ACCOMMODATE THE SPECIFIED CEILING HEIGHT, WITH 2" ADDED FOR FIELD VARIATIONS. WHERE POSSIBLE, THIS 2" SHOULD EXTEND INTO THE CEILING.

- A MINIMUM 24 GA. CHANNEL STUD MUST BE SECURELY ANCHORED TOP AND BOTTOM TO INSURE POSITIVE ATTACHMENT OF ALUMINUM RETAINERS. IF TRUSS STUDS ARE USED, CHANNEL STUDS MUST BE USED AT CORNER.
- ANGLES ONLY AVAILABLE BETWEEN 45° - 160°.
- FOR ALL ANGLES LESS THAN 78° OR GREATER THAN 154°, RETAINER WILL BE FACTORY SPLIT.

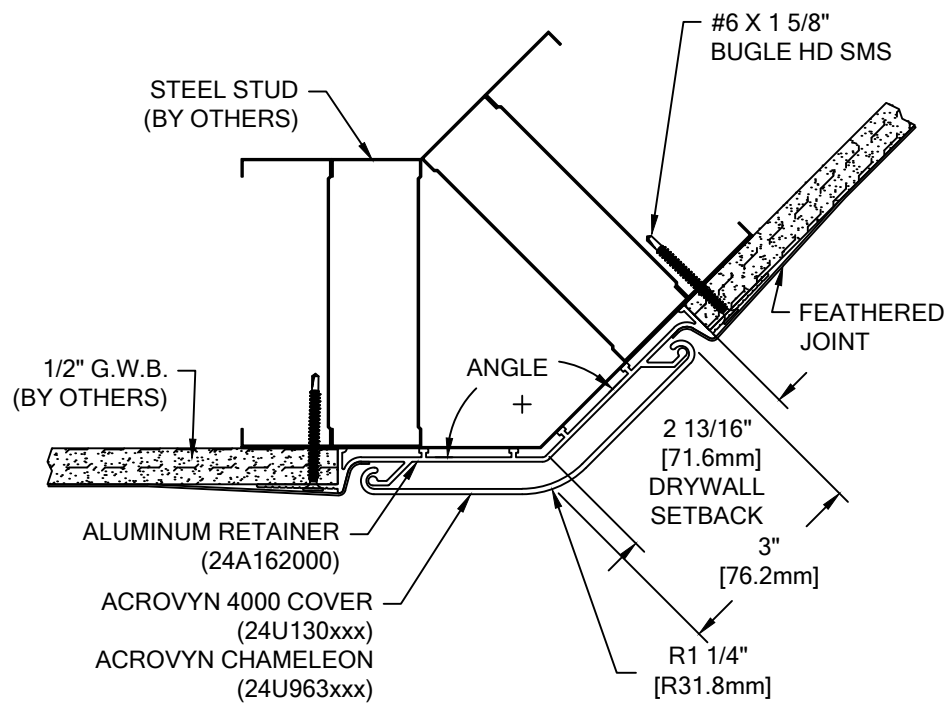
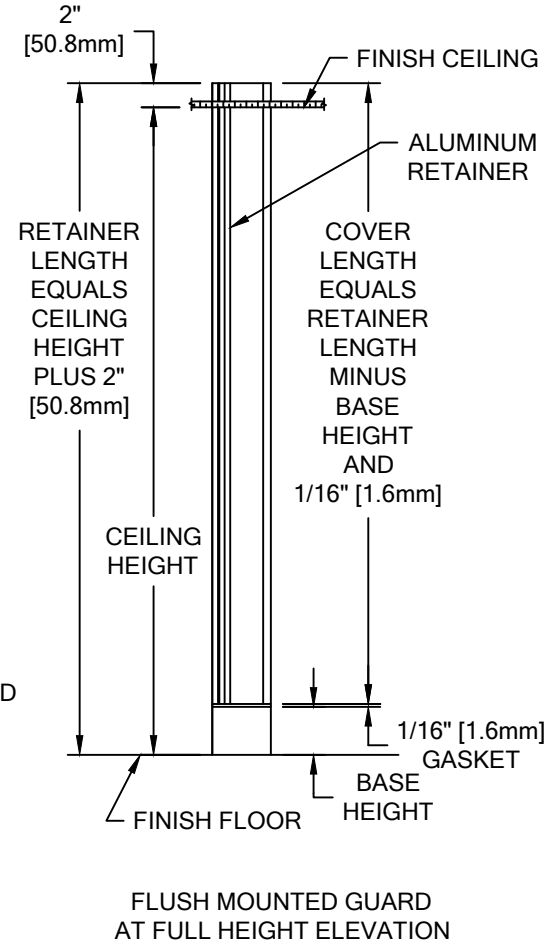

## FS-10NM ACROVYN 4000

WALL CONDITION	SPECIFIED FASTENER	DRILL DIAMETERS		CS PART NUMBER
		WALL	RETAINER	
STEEL STUD/GYPSUM WALL WOOD STUD/GYPSUM WALL	#6 X 1 5/8" BUGLE HEAD SMS	N/A	N/A	90H079002

 <p>Hughesville, PA   800.233.8493   570.546.5941 Mississauga, ON   888.895.8955   905.274.3611 <a href="http://www.c-sgroup.com">www.c-sgroup.com</a></p> <p>© Copyright 2016 Construction Specialties, Inc.</p>	<b>PROJECT:</b>	<b>REVISION:</b>
	<b>JOB NO.:</b>	<b>F&amp;F:</b>
	<b>CUSTOMER:</b>	
	<b>REP:</b>	<b>DATE:</b>
	<b>DRAWN BY:</b>	<b>SHEET NO:</b>