

# MODEL RFD/RFWD-100/400 INSTALLATION INSTRUCTIONS

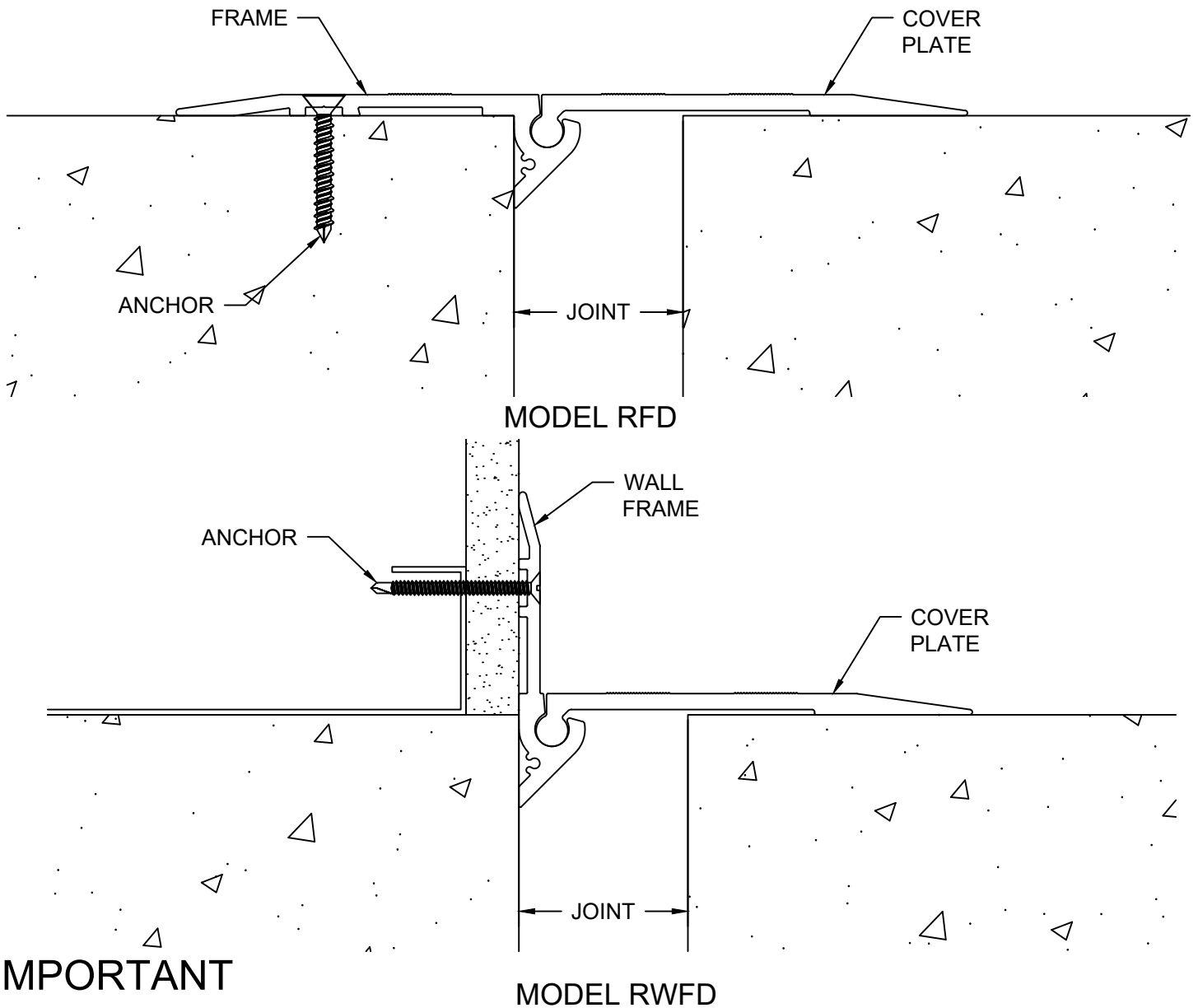

## IMPORTANT INFORMATION

Prior to the commencement of installation, all materials **MUST** be inspected for damage. Any damage must be reported to CONSTRUCTION SPECIALTIES, INC., as soon as possible, so that replacement materials may be furnished without delay.

All work must be completed as per Architect's Approved "Shop Drawings", and in accordance with these Installation Instructions. When installation is complete, all materials must be protected from damage until the Architect's FINAL INSPECTION.

### IMPORTANT:

**READ THROUGH ALL INSTRUCTIONS PRIOR TO STARTING INSTALLATION**

4/11/22



**Construction Specialties™**

6696 Route 405 Highway, Muncy PA 17756  
(800) 233-8493, Fax (570) 546-5169, www.c-sgroup.com

This document is the property of Construction Specialties, Inc. and contains CONFIDENTIAL PROPRIETARY INFORMATION that is not to be disclosed to third parties and is not to be used without approval in writing from Construction Specialties, Inc.

### Notes

Before beginning installation, review the architectural drawings and approved Construction Specialties Inc. shop drawings to familiarize yourself with the joint cover models and locations.

Check all of the joint cover components to confirm that the correct joint cover model and size have been received. Also, check for materials that may have been damaged during shipping. Report all incorrect and/or damaged components to C/S at 800-233-8493.

Read through all the steps of these instructions prior to beginning work.

# STEP 1

## PREPARE FLOOR SLAB

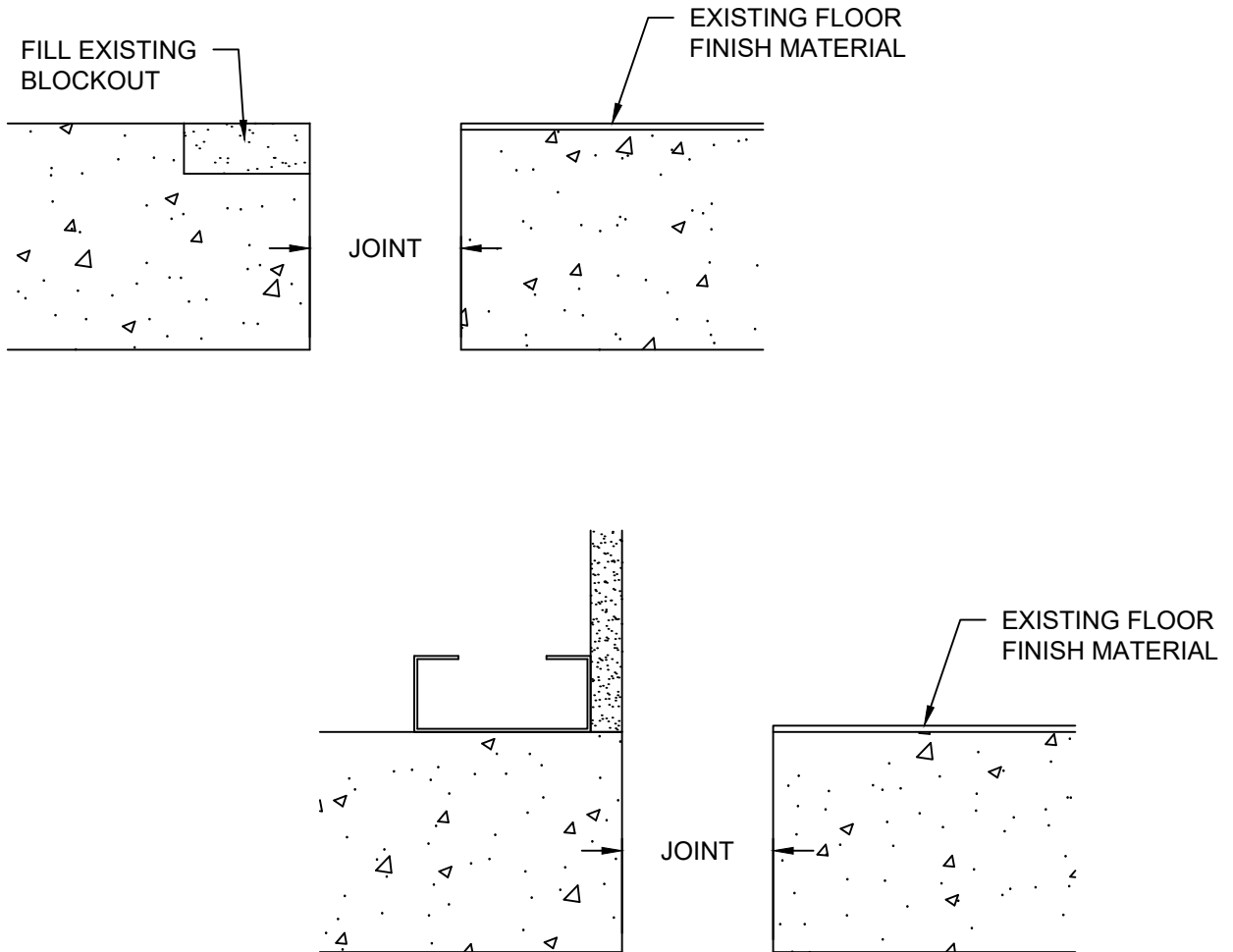

### Step 1:

1.1) Where necessary, prepare the floor slab for installation of the joint cover:

- Fill any existing joint cover blockout to level and smooth.
- RFD joint covers can be mounted over existing floor finish materials or direct to concrete slab.

# STEP 2

## FLOOR COVER ASSEMBLY INSTALLATION

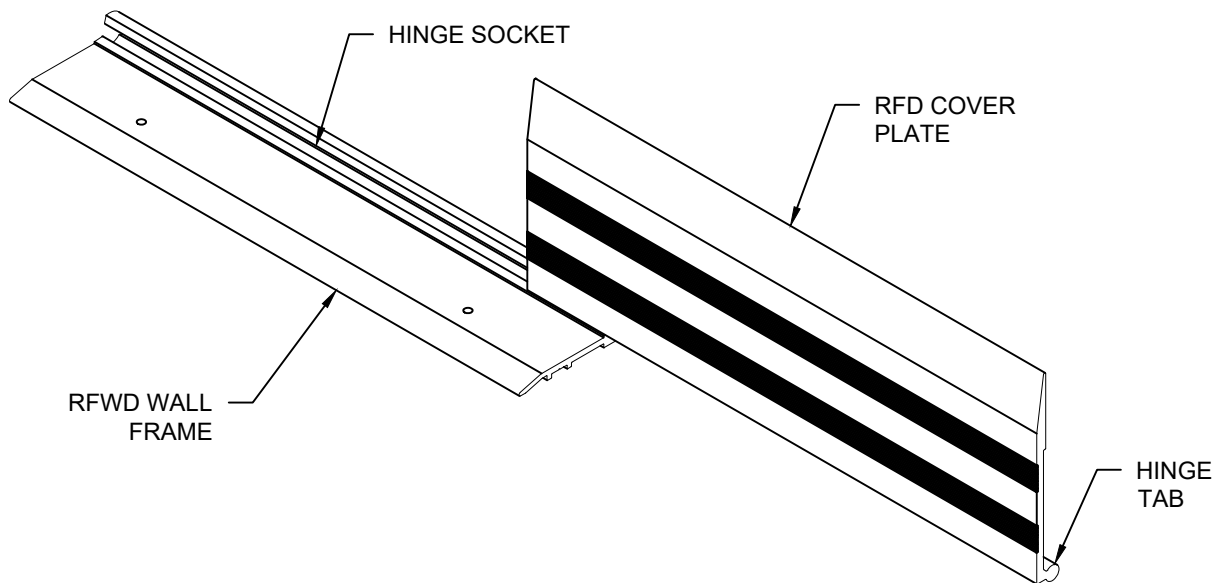
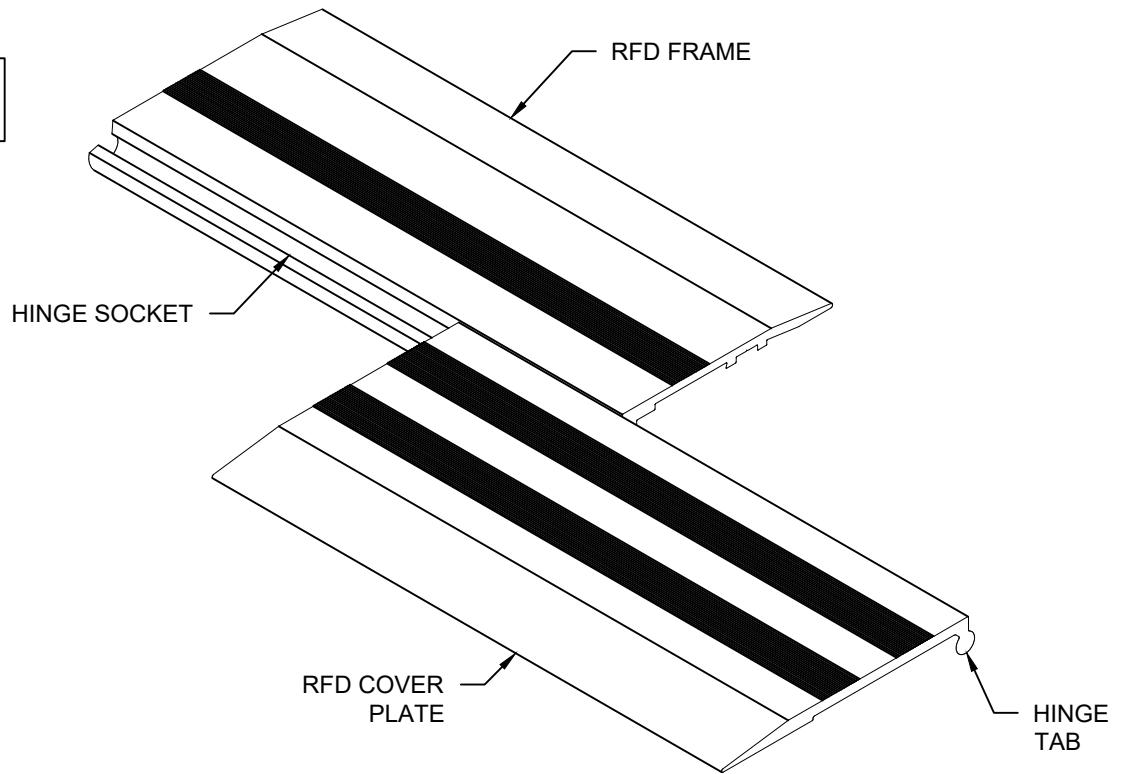

### STEP 2:

#### Note:

If a C/S Fire Barrier is to be installed in the joint, please review the Fire Barrier Installation Instructions supplied, and if required install the Fire Barrier **BEFORE** installation of C/S Seismic Expansion Joint Assemblies. If a Vapor Barrier is to be installed in the joint, please review the Vapor Barrier Installation Instructions supplied, and if required install the Vapor Barrier **BEFORE** installation of C/S Expansion Joint Cover Assemblies.

Note: The RFD/RFDW aluminum extrusions have been provided in 10' lengths.

- 2.1) Before installation, measure the length of the first run of joint cover. If needed, measure mark and cut a length of Frame and a length of Cover Plate to the appropriate length.
- 2.2) Place the length of Frame on a flat surface. Align the hinge tab on the Cover Plate with the hinge slot of the Frame (as shown above) and insert the Cover Plate into the Frame.
- 2.3) Slide the Cover Plate inward the full length and align the ends of the Frame and Cover Plate. Note: The pieces should slide together, however, applying a lubricant such as soapy water, WD-40, light grease will help to ease the assembly. **DO NOT FORCE** piece together. If there is resistance when inserting from one end, try inserting from the opposite end.

# STEP 3

## FLOOR COVER INSTALLATION

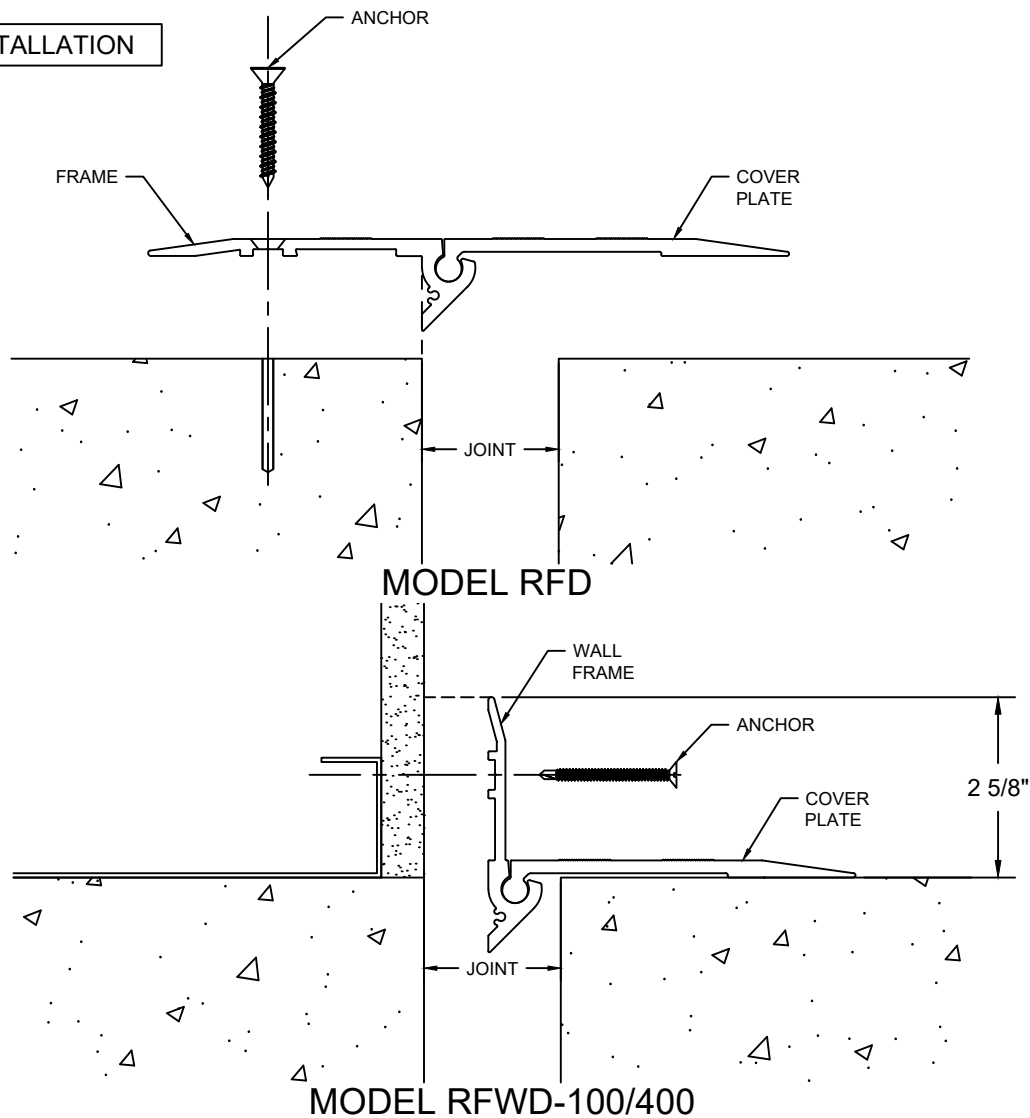

### STEP 3:

3.1) Place the assembled joint cover over the joint with the Frame on the appropriate side of the joint opening. (Note: If the floor surfaces are not level, the Frame should be placed on the higher floor.) For RFD models, seat the Frame and Cover on the floor surface. Place the Frame tight to the joint face. For RFD (floor-to-wall) models, place pencil marks on the wall face at 2 5/8" (for RFD-100/400) above the floor surface. Position the joint cover over the joint and align the top edge of the Frame with the pencil marks on the wall.

3.2) Using the Frame as a template, mark the location for each anchor hole. Remove the joint cover and drill the holes for the C/S supplied anchors in accordance with the anchor manufacturer's instructions. For floor-to-wall anchoring into g.w.b./stud construction, it is not necessary to remove the cover to drill anchor holes.

3.3) Reposition the Cover Assembly over the joint and attach using the C/S supplied anchors per manufacturer's guidelines.

# STEP 4

## FLOOR COVER INSTALLATION

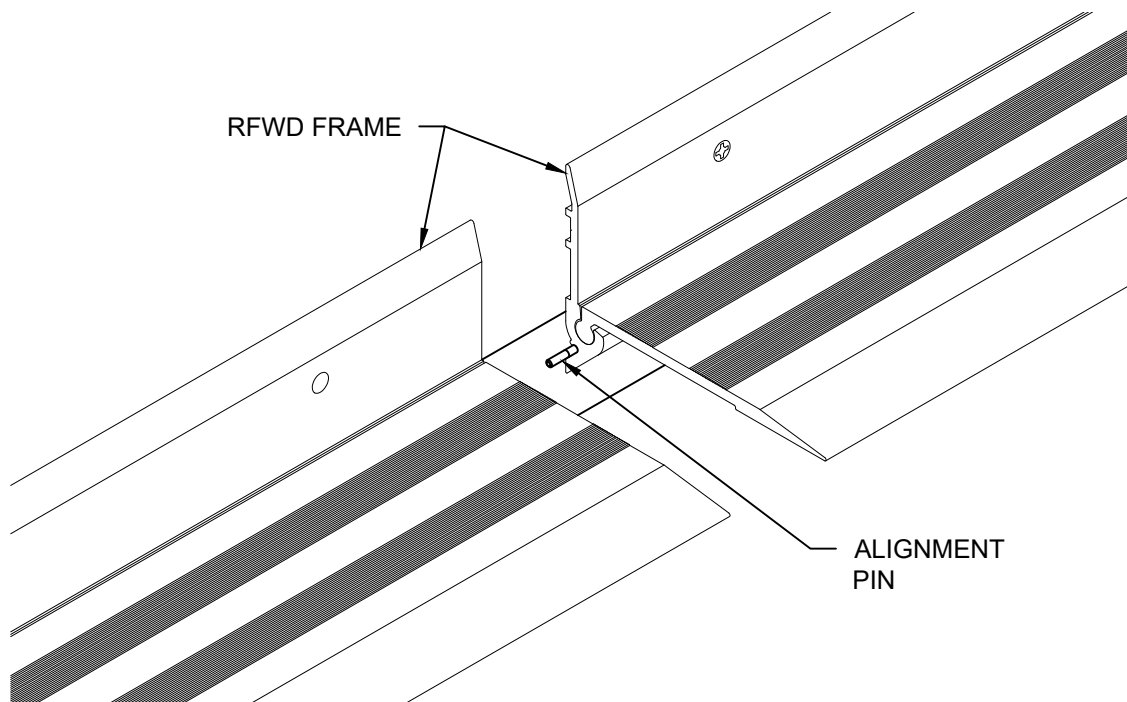
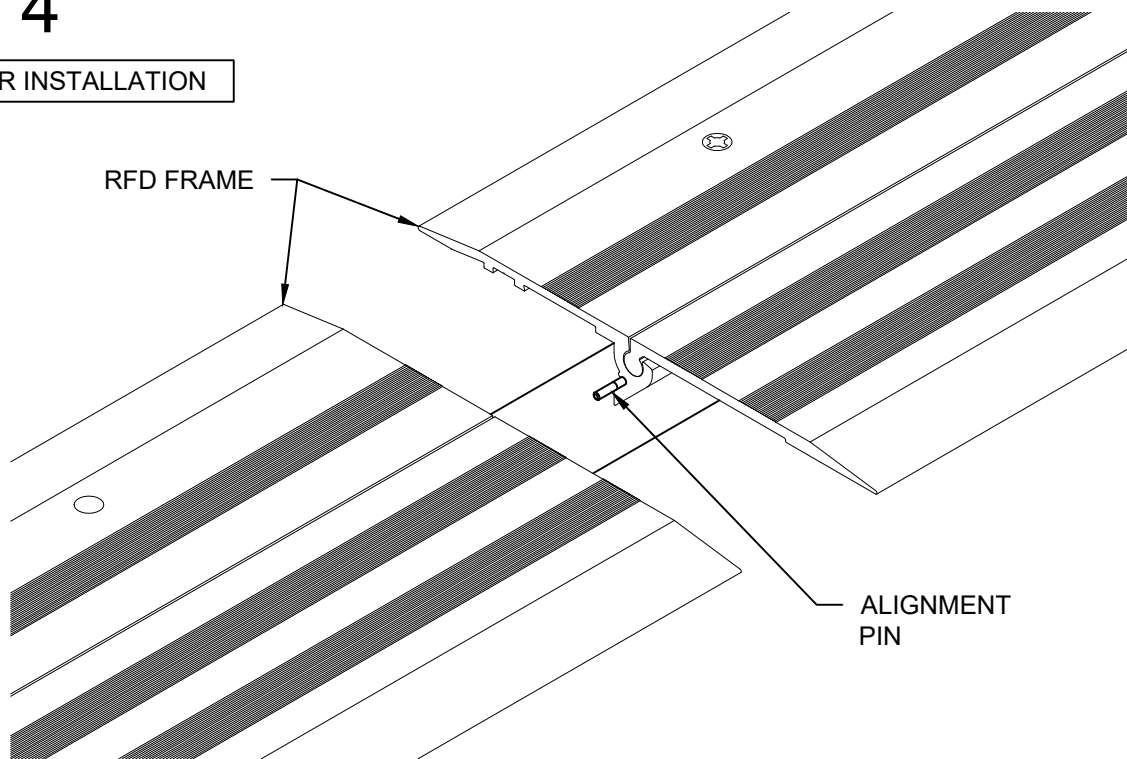

### STEP 4: (When additional lengths of cover are needed for the run.)

- 4.1) Measure the distance from the previous assembly to the end of the run. If needed, measure, mark and cut a length of Frame and Cover Plate to the required length. (Note: The cover assembly requires a minimum of (2) anchor holes. If the cut length is such that only one anchor hole remains, drill and countersink an additional hole.) Assemble the Frame and Cover Plate per Step 1.
- 4.2) Place the cover assembly over the joint and mark the holes for the anchors per Step 1. (Note: For interior applications, leave a 1/16" gap between assemblies for expansion. For exterior applications, leave a 1/8" gap.) Remove the assembly.
- 4.3) Before placing the cover assembly for installation, insert a C/S supplied Alignment Pin into the pin slot at the lower portion of the Frame. Insert the Pin in the slot and using a hammer, tap the pin in so that approximately 1/2 its length is left extending.
- 4.4) Reposition the cover assembly over the joint adjacent to the previously installed cover. Align the pin with the slot in the installed Frame and tap the opposite end of the cover assembly to drive the pin into the slot. (Note: For interior applications, leave a 1/16" gap between assemblies for expansion. For exterior applications, leave a 1/8" gap.) When the end of the run occurs at the face of a wall, it may not be possible to use the alignment pin, or the final and previous cover assemblies will have to be connected with the alignment pin prior to placement over the joint.
- 4.5) Proceed to anchor the cover assembly per Step 1.

Note: The Frame alignment pins may also be applied at the transition from the RFD (floor-to-floor cover) to RFWD (floor-to-wall) cover. See reference detail on page 6.

# STEP 4 (cont.)

FLOOR COVER INSTALLATION

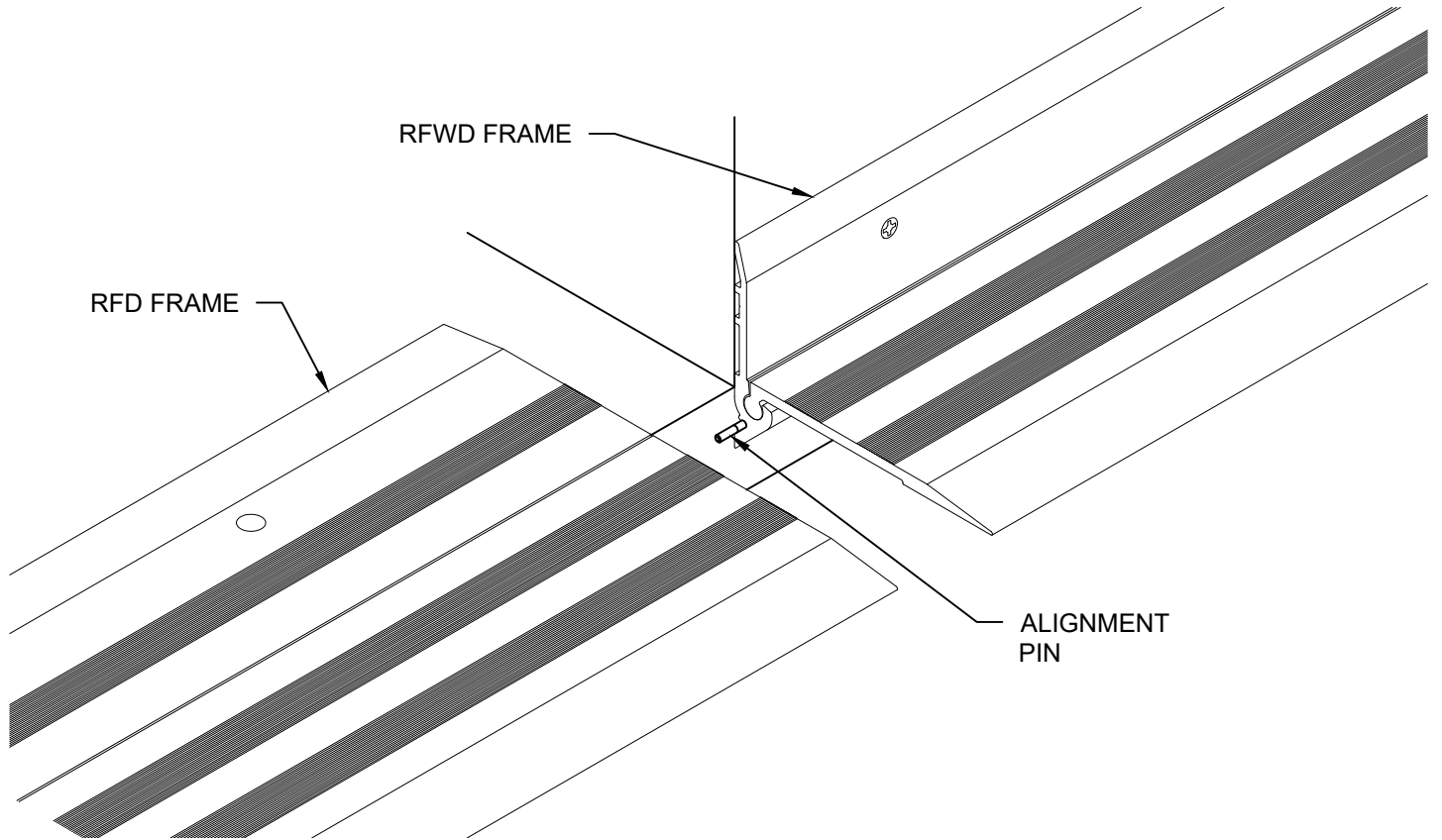

RFD TO RFWD TRANSITION

# STEP 5

## COMPLETE INSTALLATION

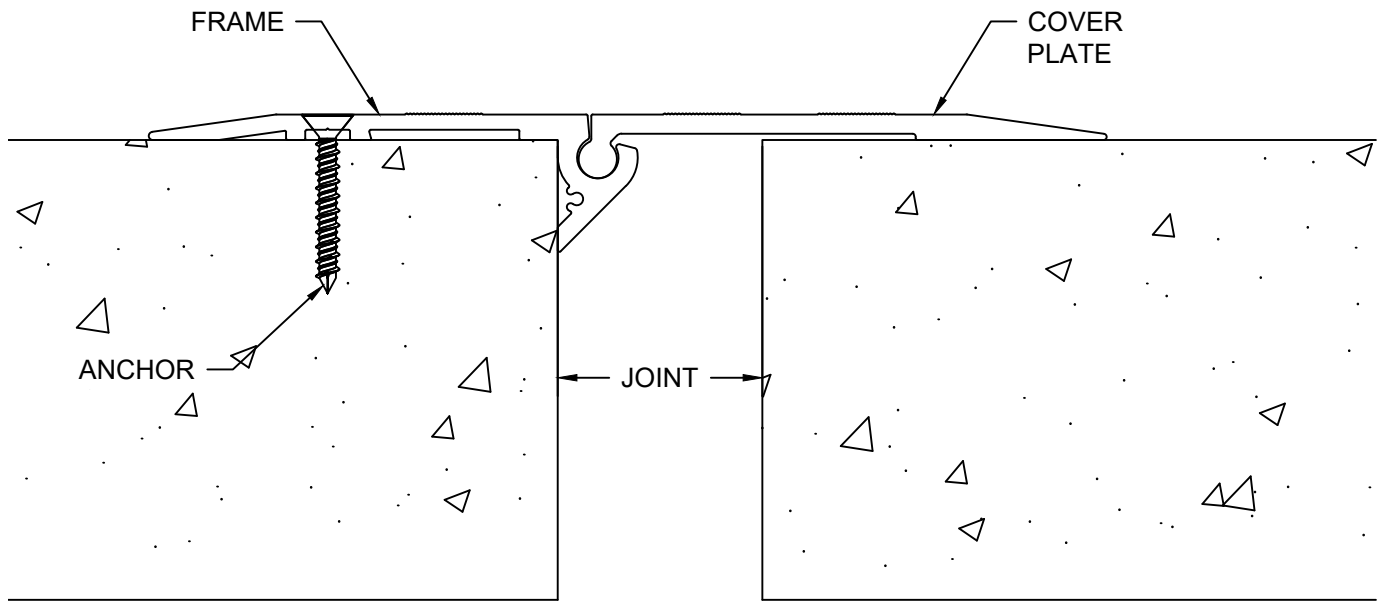

FLOOR TO FLOOR (RFD)

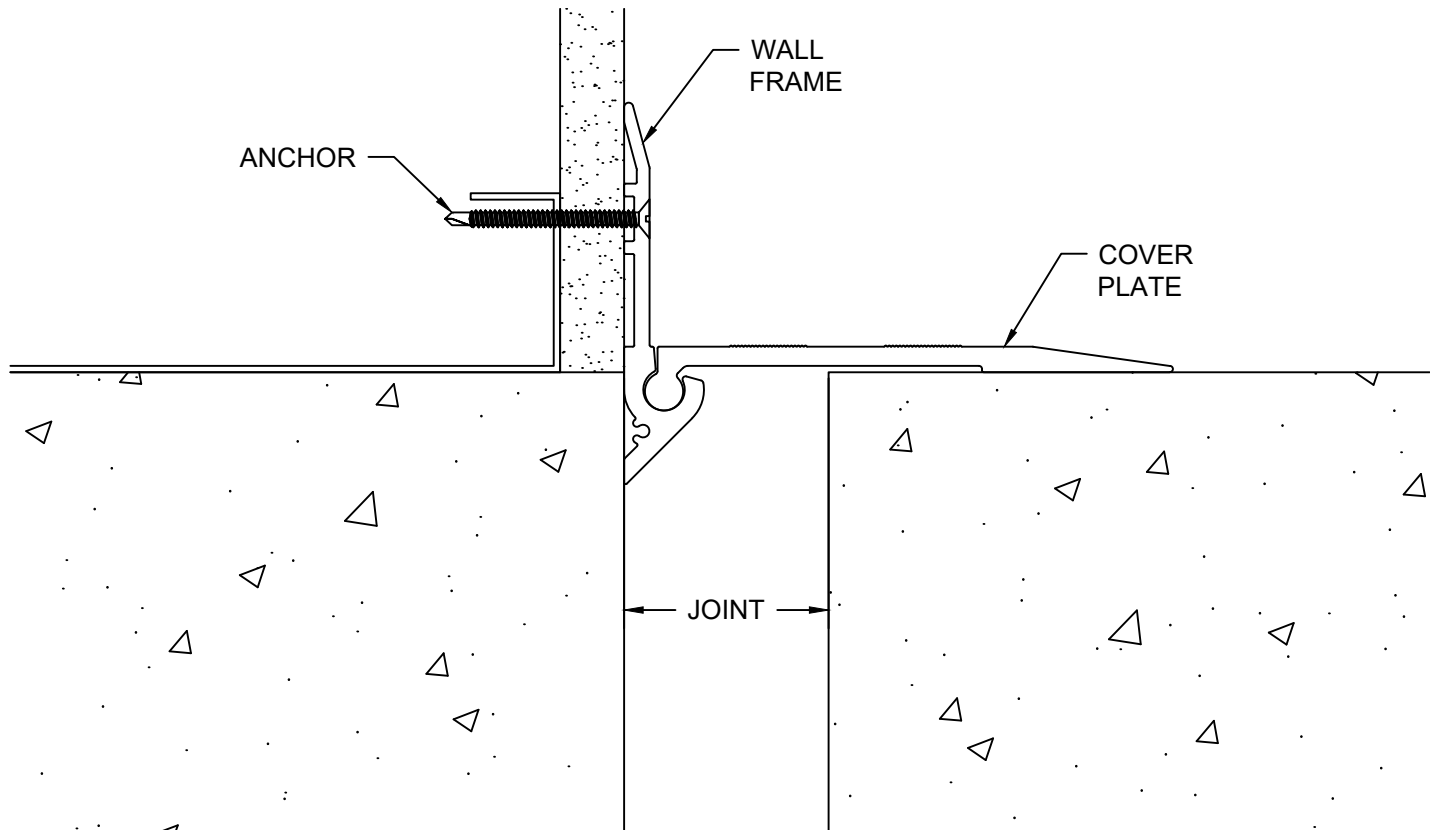

FLOOR TO WALL (RFWD)

### STEP 5:

- 5.1) When installation of the C/S Floor Expansion Joint Cover has been completed remove all residue and foreign matter from the area and joint cover.
- 5.2) Clean the C/S Joint Cover and adjoining surfaces with proper cleaner.
- 5.3) Protect the Joint Cover until the Architect's final inspection.