

## BG-30N CRASH RAIL

### PLEASE READ

PLEASE READ THESE INSTRUCTIONS THOROUGHLY PRIOR TO BEGINNING THE BG-30N CRASH RAIL INSTALLATION!

THIS INSTRUCTION SHEET IS INTENDED TO PROVIDE A SPECIFIC GUIDE TO FOLLOW FOR THE INSTALLATION OF THIS BG-30N CRASH RAIL. CONTAINED WITHIN IS THE TECHNICAL INFORMATION AND INSTALLATION TECHNIQUES REQUIRED TO COMPLETE AN EFFICIENT, NEAT AND LONG-LASTING INSTALLATION.

INSPECT ALL MATERIALS FOR DAMAGE OR MISSING PARTS. IF YOU DISCOVER DAMAGED OR MISSING MATERIALS, IN THE USA PLEASE NOTIFY THE FACTORY AT (800) 233-8493, AND IN CANADA (888) 895-8955 FOR CUSTOMER SERVICE.

BG-30N CRASH RAIL MUST BE INSTALLED IN ACCORDANCE WITH THESE INSTRUCTIONS! FAILURE TO FOLLOW THESE INSTRUCTIONS MAY VOID ANY PRODUCT WARRANTIES AND RESULT IN AN UNSUCCESSFUL INSTALLATION. FOR SPECIFIC QUESTIONS REGARDING THE INSTALLATION OF THIS BG-30N CRASH RAIL PLEASE CALL THE FACTORY IN THE USA AT (800) 233-8493 OR EMAIL [IWPTECHSUPPORT@C-SGROUP.COM](mailto:IWPTECHSUPPORT@C-SGROUP.COM). IN CANADA CALL (888) 895-8955.

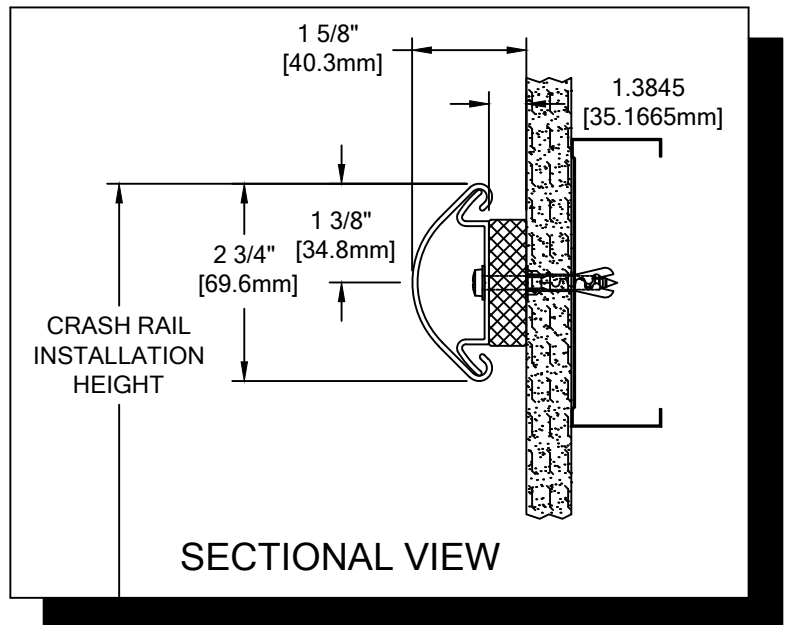

### IMPORTANT NOTES

1. ALL LINEAL MATERIAL TO BE SUPPLIED IN STOCK LENGTHS. ALUMINUM AND ACRYVYN IN LENGTHS UP TO 20'-0". THIS MATERIAL IS TO BE FIELD CUT USING QUALITY EQUIPMENT TO INSURE THAT ALL CUTS ARE SQUARE. WHEN CUTTING MATERIAL SECTIONS, CS RECOMMENDS USING AN 80-100 TOOTH CARBIDE TIPPED SAW BLADE OR EQUIVALENT, TO MINIMIZE CHIPPING AND MAINTAIN JOINT ALIGNMENT.
2. RADIAL MATERIAL MAY BE SUPPLIED FACTORY FORMED OR IN STRAIGHT LENGTHS FOR FIELD FORMING. CONSULT FACTORY FOR OPTIONS.
3. ALL DIMENSIONS ARE TYPICAL.
4. FOR DRYWALL/PLASTER WALL CONSTRUCTION, IT IS RECOMMENDED FOR FASTENERS TO BE ENGAGED INTO METAL/WOOD STUDS TO MAINTAIN MAXIMUM PULLOUT STRENGTH. IF DURING INSTALLATION YOU ENCOUNTER SPECIAL WALL CONDITIONS THAT DO NOT ALLOW FOR DIRECT ATTACHMENT TO THE STUDS PLEASE CONSULT THE LOCAL AUTHORITY HAVING JURISDICTION.
5. MATERIAL MUST REACH 65°F MIN. TO 75°F MAX. 24 HOURS PRIOR TO INSTALLATION. THIS IS ESSENTIAL TO MINIMIZE EXPANSION AND CONTRACTION OF MATERIAL.
6. ALUMINUM RETAINER SPLICE SHOULD NOT EXCEED 4" [101.6mm] DISTANCE FROM A BRACKET.
7. THE DISTANCE BETWEEN AN ACRYVYN SPLICE JOINT AND AN ALUMINUM RETAINER SPLICE JOINT SHOULD BE STAGGERED 4" [101.6mm].
8. TANGENT POINTS ON FACTORY FORMED RADIAL MATERIAL WILL BE MARKED APPROXIMATELY AND SHOULD BE CUT TO SUIT FIELD CONDITIONS.
9. THIS CRASH RAIL REQUIRES A MINIMUM OF 2 MOUNTING BRACKETS PER UNIT. THE MINIMUM END CAP-TO-END CAP CRASH RAIL LENGTH IS 8" [203.2mm].
10. FOR MORE INFORMATION ON BG-30N CRASH RAIL SEE OUR WEBSITE AT [www.c-sgroup.com](http://www.c-sgroup.com)

**BG-30N CRASH RAIL**

COMPONENTS & WALL FASTENERS



ACROVYN COVER  
(24U007xxx)  
ACROVYN WOODGRAINS  
AND BRUSHED METALS COVER  
(24U676xxx)



ALUMINUM RETAINER  
(24A130000)



MOUNTING CUSHION  
(24I066108)

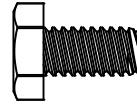

FASTENER #1  
1/4\"-20 X 1/2\"  
HEX HEAD  
MACHINE SCREW  
(90H052002)



CRASH RAIL END CAP  
(24I073xxx)  
ACROVYN WOODGRAINS  
AND BRUSHED METALS END CAP  
(24I676xxx)

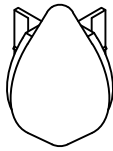

CRASH RAIL OUTSIDE  
CORNER ASSEMBLY

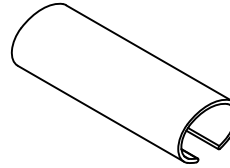

ACROVYN COVER SPLICE  
(24F038003)

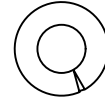

FASTENER #2  
1/4\" LOCK WASHER  
(90H006003)

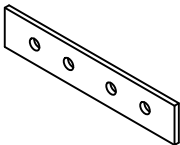

CRASH RAIL  
RETAINER SPLICE BAR  
(24I976000)

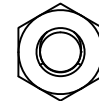

FASTENER #3  
1/4\"-20 HEX NUT  
(90H010001)

WALL CONDITION	SPECIFIED FASTENER	DRILL DIAMETERS		CS PART NUMBER
		WALL	RETAINER	
STEEL STUD/GYPSUM WALL	#10 X 2" PHILLIPS PAN HEAD SMS 1/4" FLAT WASHER SAE AF-6 PLASTIC ANCHOR	1/4"	9/32"	90H191002 90H007003 90H039004
CONCRETE/CONCRETE BLOCK	#10 X 2" PHILLIPS PAN HEAD SMS 1/4" FLAT WASHER SAE AF-6 PLASTIC ANCHOR	1/4"	9/32"	90H191002 90H007003 90H039004
WOOD STUD/GYPSUM WALL	#10 x 2-1/4" PHILLIPS PAN HEAD SMS 1/4" FLAT WASHER SAE	N/A	N/A	90H421008 90H007003
20 GA. MIN. STEEL STUD AND 20 GA. MIN. STEEL STRAPPING / GYPSUM WALL CONSTRUCTION REQUIRED (TEK SCREWS)	#6 PHILLIPS PAN HEAD BUGLE HEAD TEK SCREW	N/A	N/A	90H079002

**BG-30N CRASH RAIL**

LAYOUT VIEW

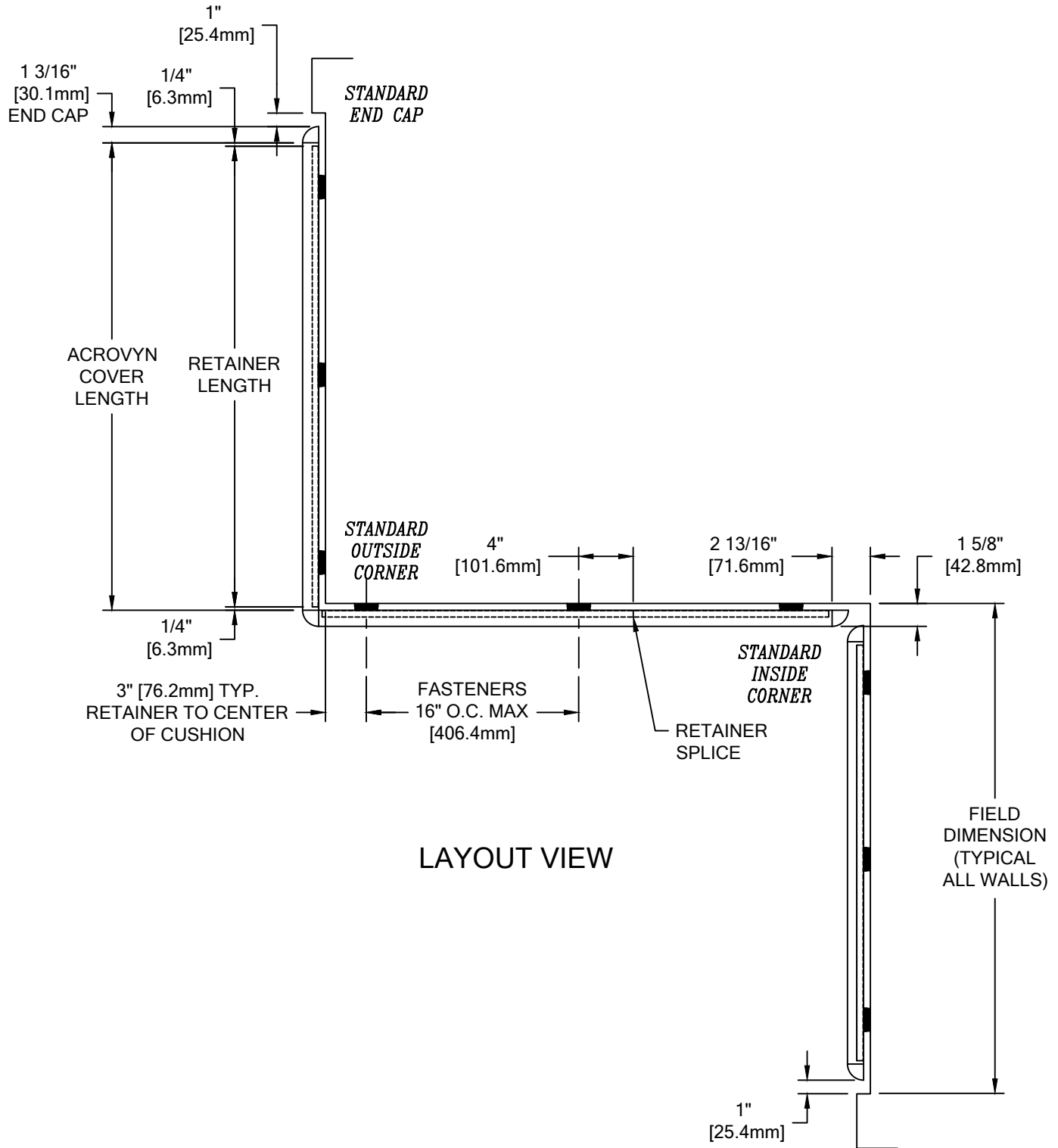

LAYOUT VIEW

**BG-30N CRASH RAIL**

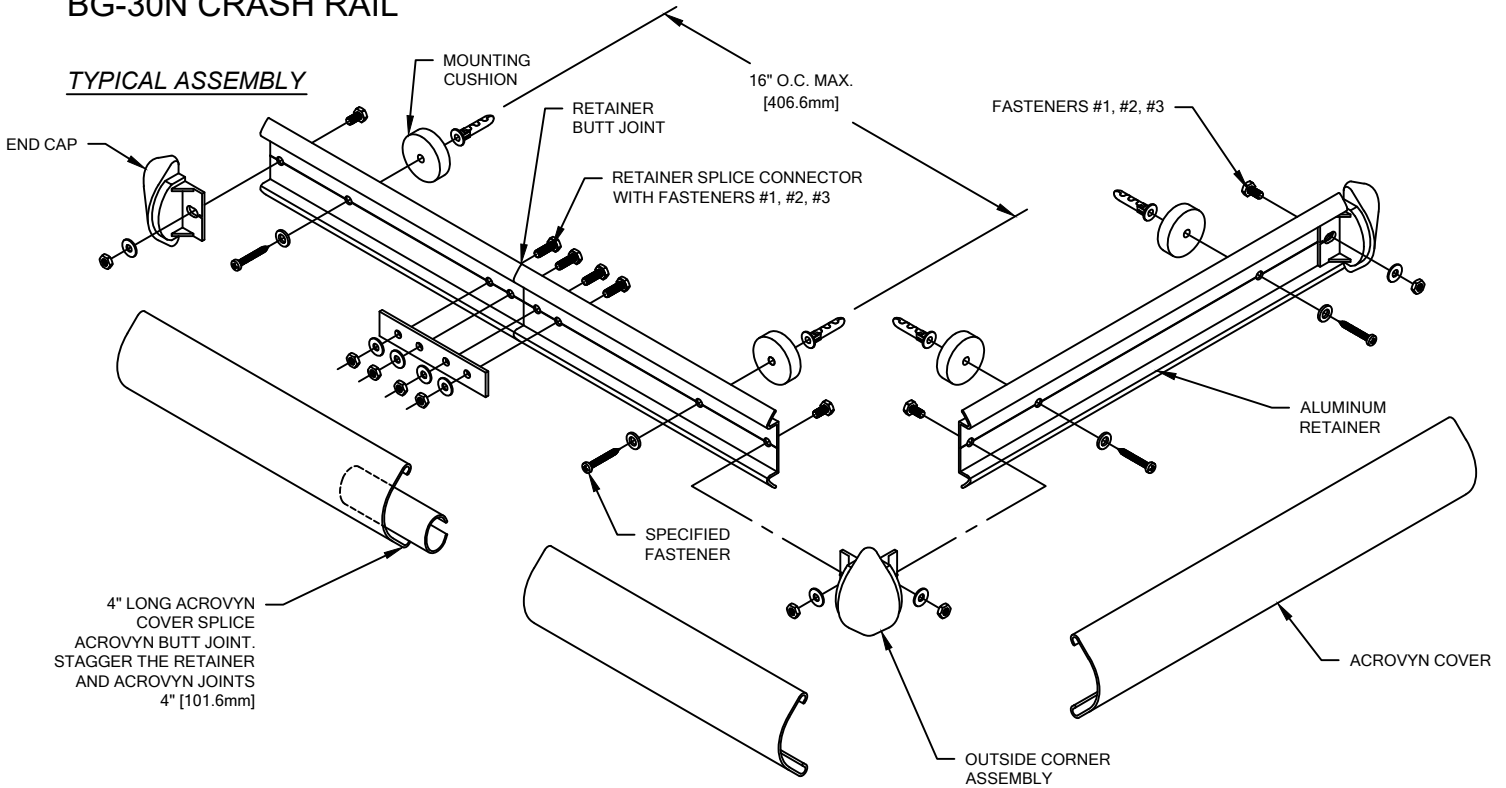

**NOTE:** INSTALLATION OF LINEAL OR RADIAL BG-30N CRASH RAIL SHOULD BE DONE IN ACCORDANCE WITH THE FOLLOWING INSTRUCTIONS.

1. ESTABLISH CRASH RAIL HEIGHT ABOVE FINISH FLOOR. DEDUCT 1 3/8" [34.9mm] AND SNAP A CHALK LINE AT THAT HEIGHT. THIS MARKS THE CENTERLINE LOCATION OF THE FASTENERS FOR THE RETAINER.
2. CUT THE CONTINUOUS ALUMINUM RETAINER TO LENGTH, USING THE REQUIRED DEDUCTIONS AS NOTED (SEE LAYOUT VIEW). PRE-DRILL CLEARANCE HOLES IN THE ALUMINUM RETAINER 3" [76.2mm] FROM EACH END AND 16" [406.4mm] O.C., ALONG V-GROOVE AS REQUIRED. REFERENCE CHART ON PAGE 2 FOR CORRECT DRILL DIAMETERS.

**NOTE:** IT IS RECOMMENDED THAT THE ACROVYN COVERS AND ALUMINUM RETAINER BE CUT WITH AN 80-100 TOOTH CARBIDE TIPPED SAW BLADE OR EQUIVALENT.

3. USING THE RETAINER AS A TEMPLATE, MARK THE LOCATIONS OF THE FASTENERS ALONG THE CHALK LINE. USE A LEVEL TO INSURE RETAINER IS PLUMB. DRILL CLEARANCE HOLES IN WALL SURFACE FOR MOUNTING HARDWARE. REFERENCE CHART ON PAGE 2 FOR CORRECT DRILL DIAMETERS.
4. ATTACH END CAPS/OUTSIDE CORNERS BY ALIGNING THE END CAP/OUTSIDE CORNER WITH THE END OF THE ALUMINUM RETAINER AND SECURING INTO POSITION USING ONE (1) 1/4-20 HEX HEAD FASTENER AT EACH END CAP AND TWO (2) AT EACH OUTSIDE CORNER.

**NOTE:** TO AID IN LOCATING THE END CAPS CORRECTLY, CUT A 4" [101.6mm] SECTION OF COVER FROM SCRAP AND SNAP IT ON THE RETAINER. LOCATE THE CAP SO IT ALIGNS FLUSH WITH TOP AND BOTTOM OF THE COVER.

5. INSTALL EACH SECTION OF ASSEMBLED RETAINER, IN SUCCESSION, USING THE MOUNTING CUSHIONS AND THE APPROPRIATE HARDWARE. USE A LEVEL TO INSURE RETAINER IS LEVEL.

**NOTE:** WHEN FIELD FORMING RADIUS CRASH RAIL, BE SURE TO APPLY NEEDED PRESSURE FROM MOUNTING CUSHION TO MOUNTING CUSHION.

6. CUT THE ACROVYN COVER TO THE PROPER LENGTH. THE COVER LENGTH IS DETERMINED BY MEASURING THE DISTANCE BETWEEN THE INSTALLED END CAPS AND/OR OUTSIDE CORNER ASSEMBLIES.

**NOTE:** IT IS RECOMMENDED THAT THE ACROVYN COVERS BE CUT SLIGHTLY LONGER (1/32" UP TO 5'-0", 1/16" OVER 5'-0") THAN THE MEASURED DISTANCE. THIS ADDITIONAL LENGTH WILL PROVIDE FOR A TIGHTER COVER-TO-END CAP FIT.

7. ALIGN THE TOP OF THE ACROVYN COVER WITH THE TOP OF THE ALUMINUM RETAINER AND SNAP THE COVER ONTO THE BOTTOM SECTION OF THE RETAINER.

**NOTE:** MANUFACTURER RECOMMENDS ALL PRINTED "PRODUCT IDENTIFICATION" ON THE REAR OF THE ACROVYN PROFILE SHALL BE ORIENTED IN THE SAME DIRECTION DURING INSTALLATION TO ENSURE PROPER ALIGNMENT AT SPLICE BUTT JOINTS.

03/31/2022