

LSRR Series

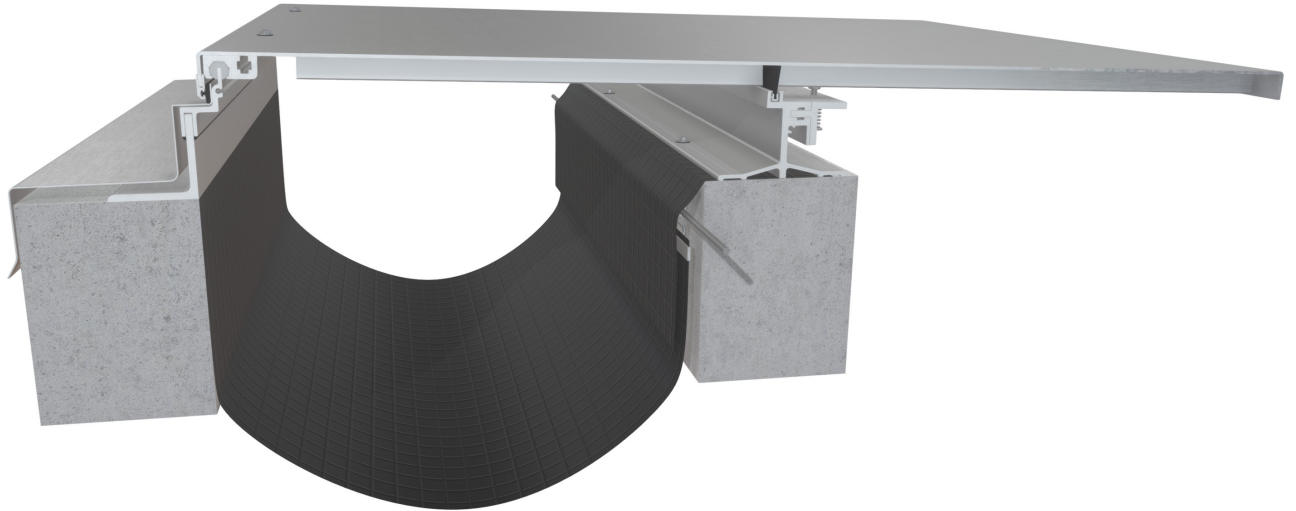

Model LSRR

This multi-axial roof cover can accommodate expansion and contraction as well as lateral shear. It is ideal for roof applications that will experience high wind loads or heavy snow loads.

Advantages

- Capable of multi-directional movement
- Accommodates high wind loads or heavy snow loads
- No exposed frame
- Sits down between parapets for a clean look
- Lightweight cover plate for easy handling and installation
- Can be accessed underneath for inspections
- Vapor Barrier included



[View 3D Model](#) →

LSRR Series

Product Details

- Standard joint sizes range from 8" - 24" (203.2mm to 609.6mm)
- 10' (304.8cm) stock lengths
- Meets ASTM E139



Model Details

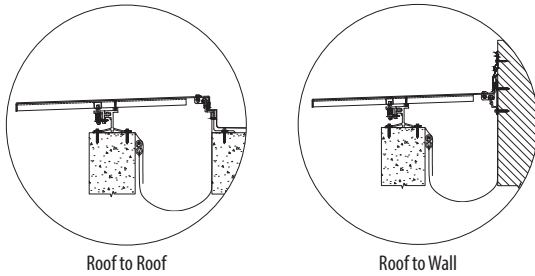

MODEL	ROOF TO ROOF	ROOF TO WALL
LSRR	●	
LSRW		●

Standard Finish



Optional Finish



Aluminum in contact with concrete/masonry will have a 2 mil heavy metal free high solids primer

See all finish options online at c-sgroup.com.

Warranty

- Standard Five-Year Warranty



Learn More →