

1 1/8" GRIDLINE 2 STAINLESS STEEL TRENCH WITH LEDGE SUPPORT ANGLE

INSERT STYLE: N/A

INSERT COLOR: N/A

CATALOG NUMBER: G62

PART NUMBER:

NO.	REVISION	DATE	BY
NO.	F&F RELEASE	DATE	BY

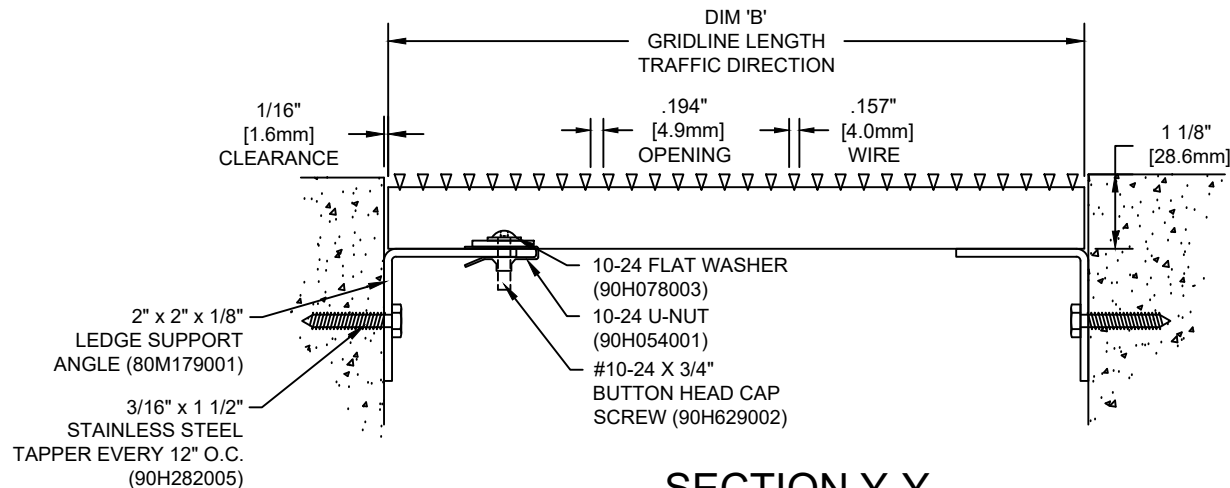

SECTION Y-Y

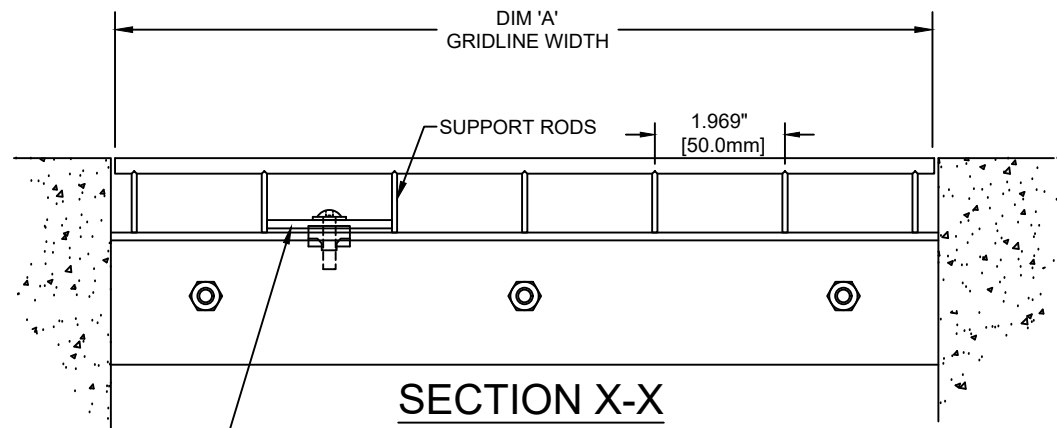

SECTION X-X

1/8" X 1-7/8" X 1-1/4" HOLD-DOWN PLATE 1 AT EACH CORNER THEN SPACE 30" O.C. SLOT SHOULD RUN PARALLEL TO SUPPORTS ALL FACING SAME DIRECTION (90F040001).

NOTES:

*MAX. SINGLE GRID SIZE NOT TO EXCEED 95-1/4" [2.419M] IN WIDTH (DIM 'A') AND 18" [0.46M] IN LENGTH (DIM 'B')
 *ALL SURFACE WIRES AND SUPPORT BARS ARE ELECTRONICALLY RESISTANCE WELDED TO ENSURE CORRECT WEIGHT BEARING PROPERTIES.

*GRIDS SHALL BE ABLE TO SUPPORT A 300LB UNIFORM LOAD.
 * SURFACE WIRE SPACING PROVIDES A 55.3% EFFECTIVE OPEN AREA FOR DIRT AND MOISTURE REMOVAL.

CS Construction Specialties™
 8696 Route 405 Highway, Muncy PA 17756
 (800) 233-8493 • Fax (570) 546-4692 • www.csgroup.com

PLEASE VERIFY ALL	QTY	MARK #	LOCATION	MODEL	DIM 'A' WIDTH	DIM 'B' LENGTH	FRAME FINISH	REMARKS

PROJECT:		
LOCATION:		
CONTRACTOR:		
AGENT:		SHT:
DRG. BY:	DATE:	JOB NO.: