

# HRBW-10CHLN HANDRAIL

HIGH LOAD HANDRAIL

## PLEASE READ

PLEASE READ THESE INSTRUCTIONS THOROUGHLY PRIOR TO BEGINNING THE HRBW-10CHLN HANDRAIL INSTALLATION!

THIS INSTRUCTION SHEET IS INTENDED TO PROVIDE A SPECIFIC GUIDE TO FOLLOW FOR THE INSTALLATION OF HRBW-10CHLN HANDRAIL. CONTAINED WITHIN IS THE TECHNICAL INFORMATION AND INSTALLATION TECHNIQUES REQUIRED TO COMPLETE AN EFFICIENT, NEAT AND LONG-LASTING INSTALLATION.

INSPECT ALL MATERIALS FOR DAMAGE OR MISSING PARTS. IF YOU DISCOVER DAMAGED OR MISSING MATERIALS, IN THE USA PLEASE NOTIFY THE FACTORY AT (800) 233-8493, AND IN CANADA (888) 895-8955.

HRBW-10CHLN HANDRAIL MUST BE INSTALLED IN ACCORDANCE WITH THESE INSTRUCTIONS! FAILURE TO FOLLOW THESE INSTRUCTIONS MAY VOID ANY PRODUCT WARRANTIES AND RESULT IN AN UNSUCCESSFUL INSTALLATION. FOR SPECIFIC QUESTIONS REGARDING THE INSTALLATION OF HRBW-10CHLN HANDRAIL PLEASE CALL THE FACTORY AT (800) 233-8493 OR EMAIL [IWPTECHSUPPORT@C-SGROUP.COM](mailto:IWPTECHSUPPORT@C-SGROUP.COM). IN CANADA CALL (888) 895-8955.

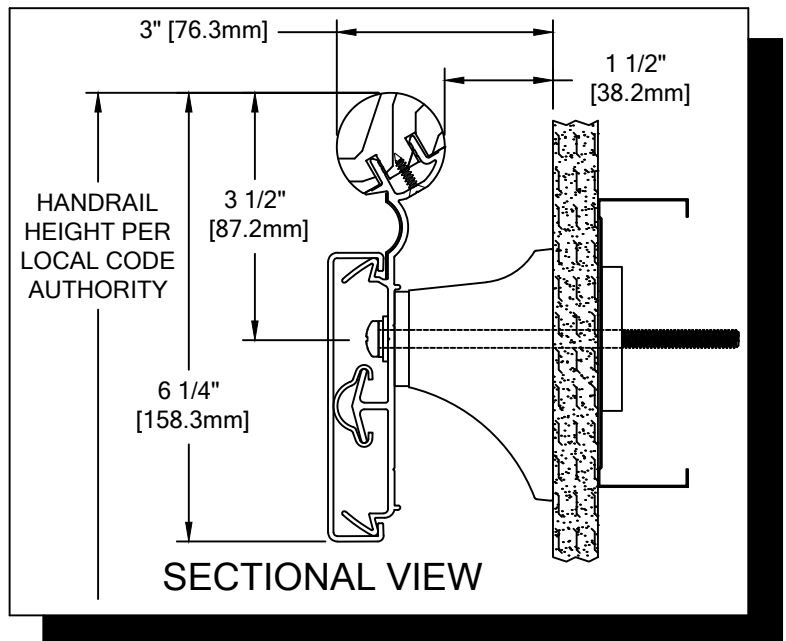

## IMPORTANT NOTES

1. DUE TO WOOD BEING A NATURAL PRODUCT, COMPONENTS MAY GROW AND SHRINK AT DIFFERENT RATES. BECAUSE OF THIS, C/S HAS DESIGNED THIS HANDRAIL TO UTILIZE A BEVEL AS SHOWN IN THESE INSTRUCTIONS (SEE ILLUSTRATION 1). THIS BEVEL MUST BE APPLIED AT ALL WOOD JOINTS AND MUST MATCH FACTORY BEVEL ON END CAPS.
2. DUE TO THE NATURE OF WOOD, COMPONENT COLORS MAY VARY, SORT WOOD COMPONENTS AND MATCH PARTS BY COLOR.
3. ALL LINEAL MATERIAL TO BE SUPPLIED IN STOCK LENGTHS. WOOD IN 7'-0" TO 12'-0" VARIABLE, AND ALUMINUM AND ACROVYN IN LENGTHS UP TO 20'-0". THIS MATERIAL IS TO BE FIELD CUT USING QUALITY EQUIPMENT TO INSURE THAT ALL CUTS ARE SQUARE. WHEN CUTTING MATERIAL SECTIONS, C/S RECOMMENDS USING AN 80-100 TOOTH CARBIDE TIPPED SAW BLADE OR EQUIVALENT, TO MINIMIZE CHIPPING AND MAINTAIN JOINT ALIGNMENT.
4. RADIAL MATERIAL MAY BE SUPPLIED FACTORY FORMED OR IN STRAIGHT LENGTH FOR FIELD FORMING. CONSULT FACTORY FOR OPTIONS.
5. ALL DIMENSIONS ARE TYPICAL.
6. FOR DRYWALL/PLASTER WALL CONSTRUCTION, IT IS RECOMMENDED FOR FASTENERS TO BE ENGAGED INTO METAL/WOOD STUDS TO MAINTAIN MAXIMUM PULLOUT STRENGTH. IF DURING INSTALLATION YOU ENCOUNTER SPECIAL WALL CONDITIONS THAT DO NOT ALLOW FOR DIRECT ATTACHMENT TO THE STUDS PLEASE CONSULT THE LOCAL AUTHORITY HAVING JURISDICTION.
7. INSTALL OUTSIDE CORNERS FIRST.
8. INSTALL LONGEST RUN OF HANDRAIL FIRST.
9. MATERIAL MUST REACH 65°F MIN. TO 75°F MAX. 24 HOURS PRIOR TO INSTALLATION. THIS IS ESSENTIAL TO MINIMIZE EXPANSION AND CONTRACTION OF MATERIAL.
10. MAY REQUIRE USE OF FIRE PUTTY WHEN INSTALLED ON FIRE WALL WITH TOGGLE BOLTS. REFERENCE INSTRUCTIONS 24FIREPUTTY FOR FIRE PUTTY INSTALLATION.
11. THIS HANDRAIL REQUIRES A MINIMUM OF 2 MOUNTING BRACKETS PER UNIT. THE MINIMUM END CAP-TO-END CAP HANDRAIL LENGTH IS 13" [330.2mm].
12. FOR HIGH LOAD HANDRAIL USE A MINIMUM 20 GA. STEEL STUD and 20 GA. STEEL STRAPPING AND 5/8" GYPSUM WALL BOARD.
13. FOR MORE INFORMATION ON HRBW-10CHLN HANDRAIL SEE OUR WEBSITE AT [www.c-sgroup.com](http://www.c-sgroup.com).

**HRBW-10CHLN HANDRAIL**

COMPONENTS & WALL FASTENERS



WOOD HANDRAIL  
(24W001xxx)



RC-10 CUSHION  
(24U952108)



ALUMINUM RETAINER  
(24A356000)

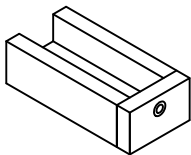

WOOD HANDRAIL  
DRILL JIG  
(90H110010)



ACROVYN 4000 COVER  
(24U009xxx)  
ACROVYN CHAMELEON  
(24U616xxx)



MOUNTING BRACKET  
(24I007xxx)

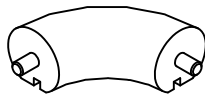

WOOD HANDRAIL  
OUTSIDE CORNER  
(24W019xxx)



CRASH RAIL END CAP  
ASSEMBLY  
(RIGHT-HAND SHOWN)  
(LEFT-HAND AVAILABLE)

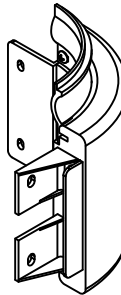

CRASH RAIL OUTSIDE  
CORNER ASSEMBLY

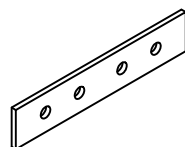

RETAINER SPLICE BAR  
(24I976000)



WOOD HANDRAIL ENDCAP  
(24W012xxx, RH SHOWN)  
(24W013xxx, LH)



ACROVYN ACCENT  
REVEAL  
(24N021xxx)



#4 X 1/2" HSS  
COUNTERSINK DRILL  
(90H035010)

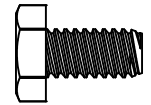

FASTENER #1  
1/4-20 X 1/2" HEX  
HEAD MACHINE SCREW  
(90H052002)

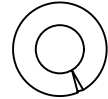

FASTENER #2  
1/4" LOCK WASHER  
(90H006003)

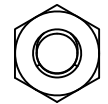

FASTENER #3  
1/4-20 HEX NUT  
(90H010001)



FASTENER #4  
#6 X 5/8" S/S PHILLIPS  
FLAT HEAD SMS  
(90H231004)

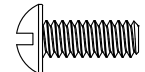

FASTENER #5  
#10-24 X 1/2" ROUND HEAD  
SLOTTED MACHINE SCREW  
(90H369002)



FASTENER #6  
#10 LOCK WASHER  
(90H370002)

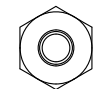

FASTENER #7  
#10 HEX NUT  
(90H368002)

WALL CONDITION	SPECIFIED FASTENER	DRILL DIAMETERS		C/S PART NUMBER
		WALL	RETAINER	
20 GA. STEEL STUD/GYPSUM WALL (HIGH LOAD)	1/4-20 X 5" S/S PHILLIPS PAN HEAD MACHINE SCREW 1/4" S/S TOGGLER WING 1/4" LOCK WASHER 1/4" FLAT WASHER	1/2"	9/32"	90H872004 90H873004 90H006003 90H007003

**HRBW-10CHLN HANDRAIL**

LAYOUT VIEW

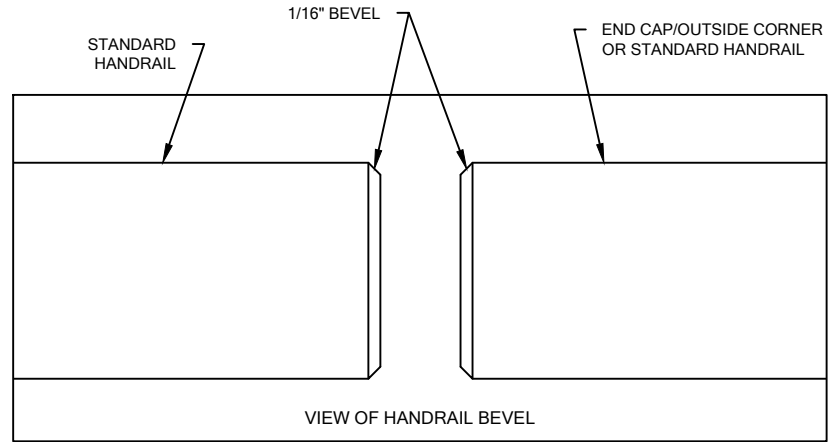
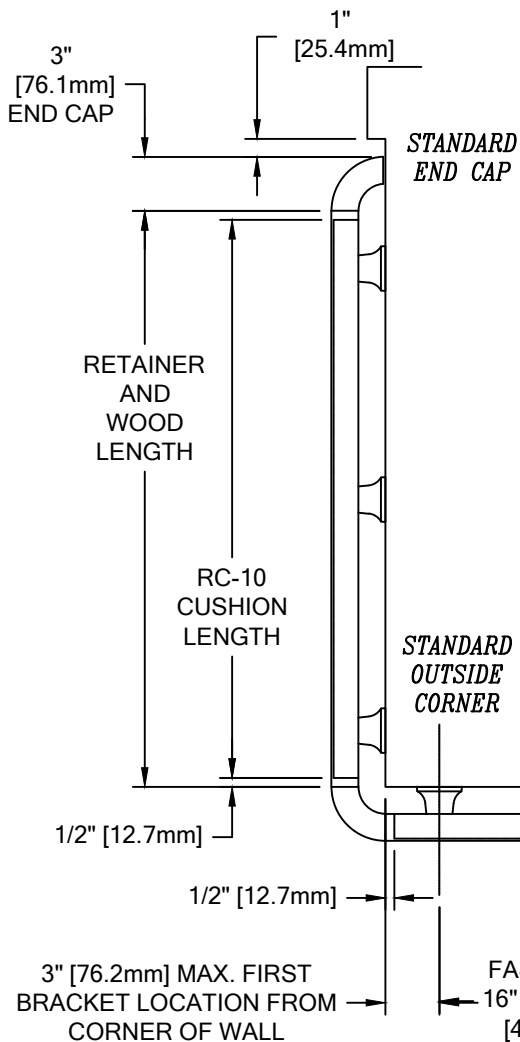

**ILLUSTRATION 1**

**LAYOUT VIEW**

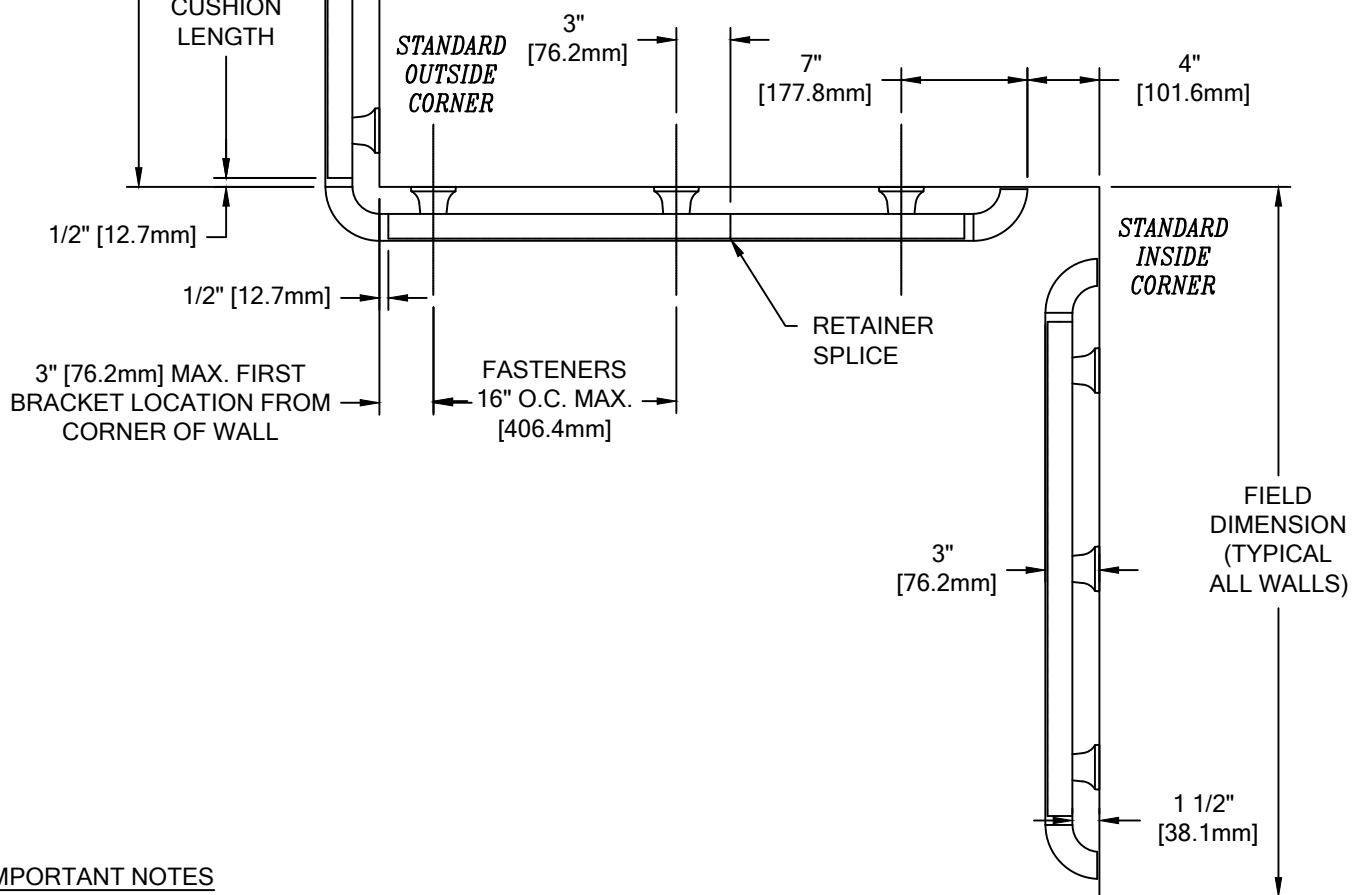

IMPORTANT NOTES

1. ALUMINUM RETAINER SPLICES SHOULD NOT EXCEED 4" [101.6mm] DISTANCE FROM A BRACKET.
2. THE DISTANCE BETWEEN AN ACROVYN SPLICE JOINT AND AN ALUMINUM RETAINER SPLICE JOINT SHOULD BE STAGGERED 4"[101.6mm].
3. TANGENT POINTS ON FACTORY FORMED RADIAL MATERIAL WILL BE MARKED APPROXIMATELY AND SHOULD BE CUT TO SUIT FIELD CONDITIONS.

**HRBW-10CHLN HANDRAIL**

TYPICAL ASSEMBLY

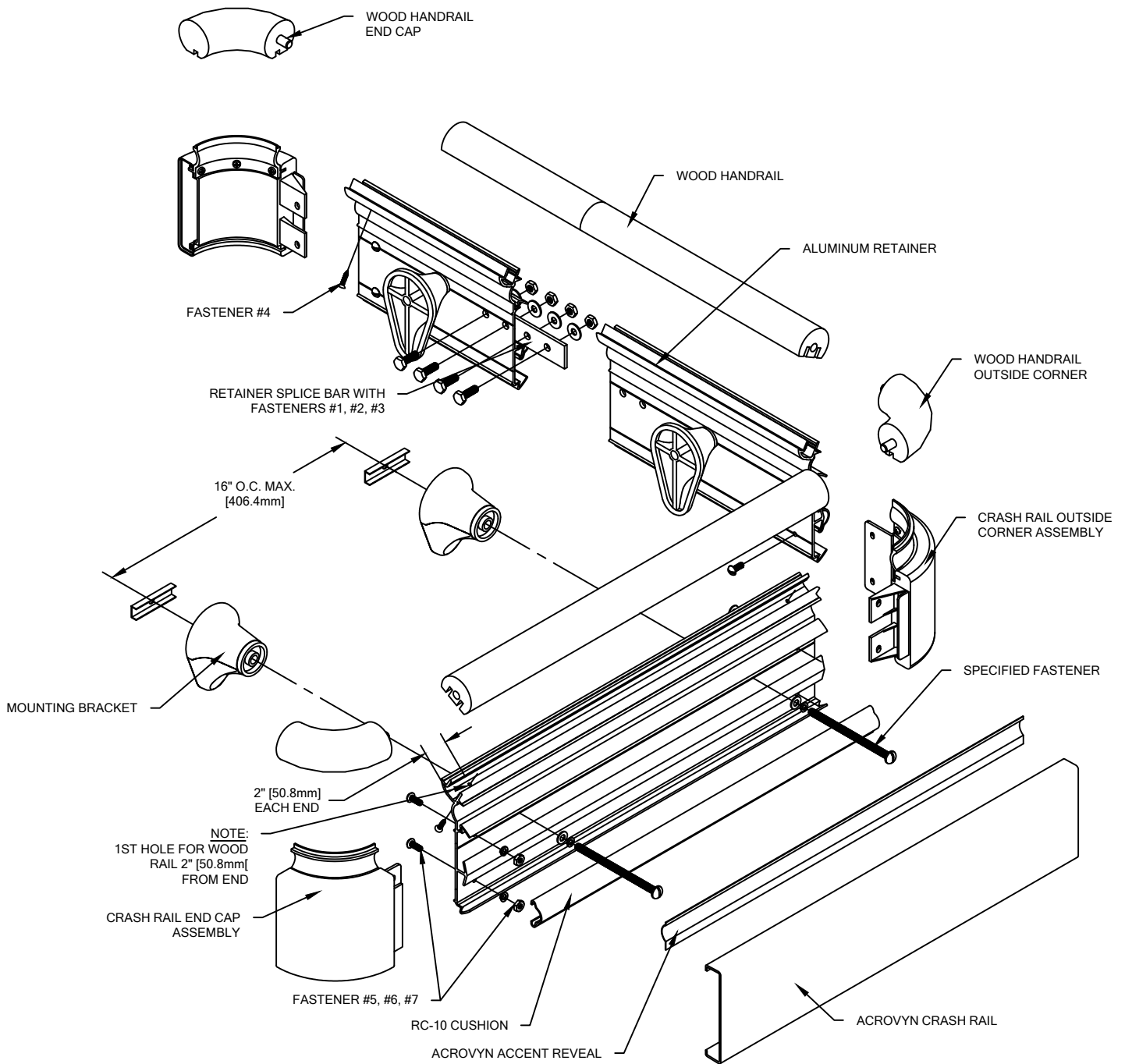

DUE TO THE NATURE OF WOOD, COMPONENT COLORS MAY VARY. SORT WOOD COMPONENTS AND MATCH PARTS BY COLOR.

**HRBW-10CHLN HANDRAIL**

**NOTE:** INSTALLATION OF LINEAL OR RADIAL HRBW-10CHLN HANDRAIL SHOULD BE DONE IN ACCORDANCE WITH THE FOLLOWING INSTRUCTIONS.

1. USE LOCAL CODE REQUIREMENTS AND ESTABLISH HANDRAIL HEIGHT ABOVE FINISH FLOOR. DEDUCT 3 1/2" [88.9mm] AND SNAP A CHALK LINE AT THAT HEIGHT. THIS MARKS THE LOCATION OF THE MOUNTING BRACKET FASTENERS.
2. CUT THE CONTINUOUS ALUMINUM RETAINER TO LENGTH USING THE REQUIRED DEDUCTIONS AS NOTED (SEE LAYOUT VIEW). PRE-DRILL CLEARANCE HOLES IN THE ALUMINUM RETAINER FOR THE MOUNTING BRACKETS 3" [76.2mm] FROM EACH END AND 16" [406.4mm] O.C. AS REQUIRED AT THE V-GROOVE ALONG THE FRONT OF THE RETAINER. FILE ALL ENDS OF RETAINER TO REMOVE BURRS AND SHARP EDGES AT HANDRAIL.

**NOTE:** IT IS RECOMMENDED THAT THE ACROVYN COVER AND ALUMINUM RETAINER BE CUT WITH AN 80-100 TOOTH CARBIDE TIPPED SAW BLADE OR EQUIVALENT.

3. DRILL CLEARANCE HOLES IN WALL SURFACE FOR MOUNTING HARDWARE, USING THE RETAINER AS A TEMPLATE. REFERENCE CHART ON PAGE 2 FOR CORRECT DRILL DIAMETER.

**NOTE:** FASTENERS MUST BE ENGAGED IN BOTH THE STRAPPING AND STUDS.

4. CUT THE RC-10 CUSHION TO LENGTH NOTING THE REQUIRED DEDUCTIONS (SEE LAYOUT VIEW) AND INSTALL ONTO ALUMINUM RETAINER.
5. MARK FASTENER LOCATIONS ALONG V-GROOVE ON BACK OF RETAINER (SEE SECTIONAL VIEW). FASTENERS START 2" [50.8mm] FROM THE ENDS OF RETAINER AND ARE 24" [609.6mm] ON CENTER. USE THE SUPPLIED COUNTERSINKING DRILL FOR HOLES ALONG V-GROOVE WHERE WOOD HANDRAIL FASTENS TO RETAINER. THIS WILL ALLOW SCREW HEADS TO BE FLUSH WITH RETAINER WHEN ASSEMBLED.
6. CUT ACCENT REVEAL TO LENGTH AND INSERT INTO SLOT PROVIDED IN THE TOP SECTION OF THE ALUMINUM RETAINER.

**NOTE:** SEE PAGE 8 FOR CHAMELEON REVEAL INSTALLATION.

7. ATTACH END CAP/OUTSIDE CORNERS BY SLIDING THE END CAP ONTO THE END OF THE ALUMINUM RETAINER AND SECURING INTO POSITION USING TWO (2) #10-24 X 1/2" RD HD SLOTTED MACHINE SCREW WITH LOCK WASHER AND #10 HEX NUT AT EACH END CAP AND FOUR (4) AT EACH OUTSIDE CORNER.

**NOTE:** TO AID IN LOCATING THE END CAPS CORRECTLY, CUT A 4" [101.4mm] SECTION OF COVER FROM SCRAP AND SNAP IT ON THE RETAINER. LOCATE THE CAP SO IT ALIGNS FLUSH WITH THE TOP AND BOTTOM OF THE COVER.

8. CUT WOOD TOP RAIL TO EXACT LENGTH OF RETAINER. BEVEL THE CUT EDGES ON HANDRAIL END SLIGHTLY WITH 150 GRIT SANDPAPER TO MATCH BEVEL ON WOOD END CAPS (SEE ILLUSTRATION 1). TOUCH UP SANDED EDGES WITH STAIN MARKER.

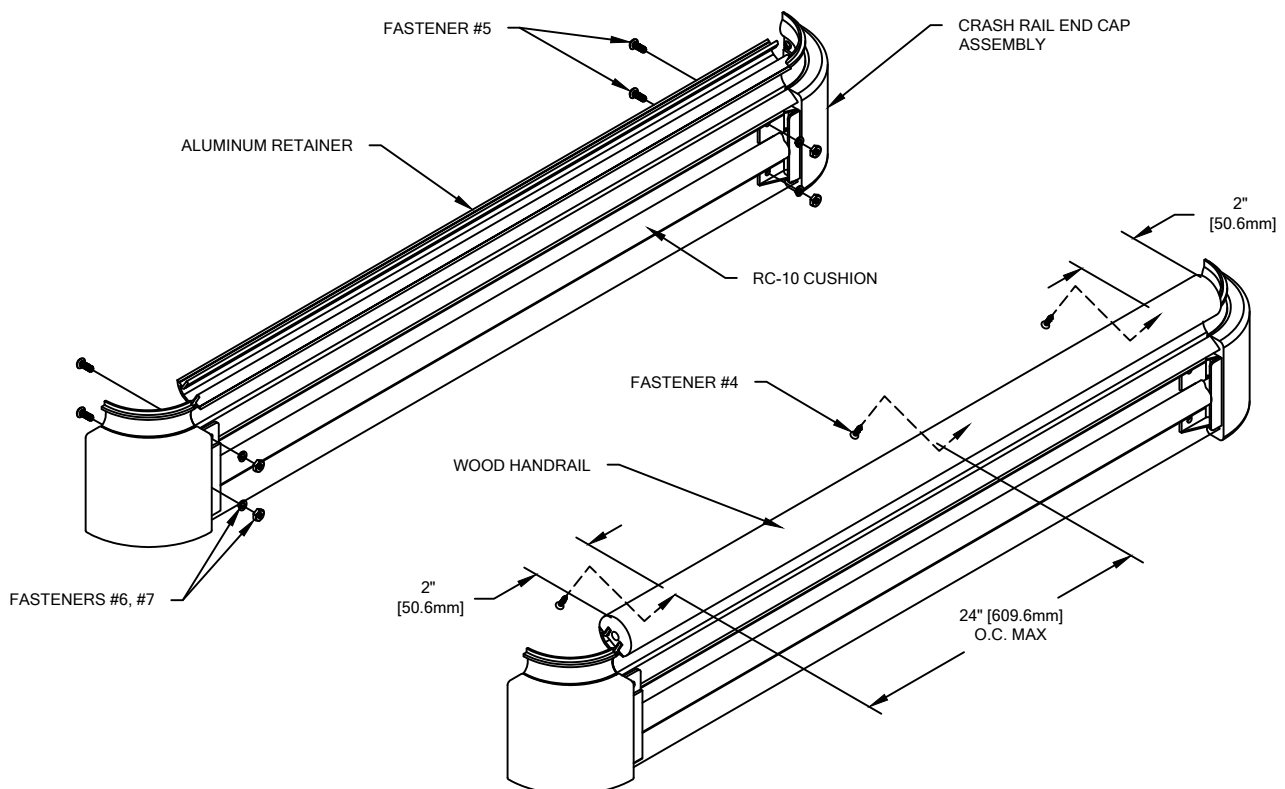

**HRBW-10CHLN HANDRAIL**

9. USING THE HOLE IN THE ALUMINUM RETAINER AS A GUIDE, DRILL 3/32" DIAMETER PILOT HOLES 3/8" DEEP INTO THE WOOD HANDRAIL. ATTACH THE TOP RAIL TO THE RETAINER USING THE #6 X 5/8" PHILLIPS FLAT HEAD SHEET METAL SCREWS.
10. ATTACH WOOD END CAPS TO TOP RAIL BY SLIDING THE END CAP DOWEL INTO THE ALIGNMENT HOLE IN THE RAIL. WOOD GLUE MUST BE APPLIED TO THE DOWEL PRIOR TO INSERTION. APPLY HOT MELT GLUE (NOT SUPPLIED) ON THE REVERSE SIDE OF THE END CAP WHERE THE ADAPTOR FITS INTO THE BOTTOM GROOVE OF THE TOP CAP.

**NOTE:** SEE PAGE 8 FOR INSTRUCTIONS ON DRILLING ALIGNMENT HOLE IN WOOD HANDRAIL.

11. INSTALL EACH SECTION OF ASSEMBLED RETAINER IN SUCCESSION USING ACROVYN MOUNTING BRACKETS AND APPROPRIATE FASTENERS. REFERENCE CHART ON PAGE 2. USE LEVEL TO ASSURE RETAINER IS LEVEL.

**NOTE:** WHEN FIELD FORMING RADIUS HANDRAIL, BE SURE TO APPLY NEEDED PRESSURE FROM BRACKET TO BRACKET.

12. CUT THE ACROVYN COVER TO THE PROPER LENGTH. THE COVER LENGTH IS DETERMINED BY MEASURING THE DISTANCE BETWEEN THE INSTALLED END CAPS AND/OR OUTSIDE CORNER ASSEMBLIES.

**NOTE:** IT IS RECOMMENDED THAT THE ACROVYN COVER BE CUT SLIGHTLY LONGER (1/32" UP TO 5'-0", 1/16" OVER 5'-0") THAN THE MEASURED DISTANCE. THIS ADDITIONAL LENGTH WILL PROVIDE FOR A TIGHTER COVER-TO-END CAP FIT.

13. ALIGN THE TOP OF THE ACROVYN COVER WITH THE TOP OF THE ALUMINUM RETAINER AND SNAP THE COVER ONTO THE BOTTOM SECTION OF THE RETAINER.

**NOTE:** MANUFACTURER RECOMMENDS ALL PRINTED "PRODUCT IDENTIFICATION" ON THE REAR OF THE ACROVYN PROFILE SHALL BE ORIENTED IN THE SAME DIRECTION DURING INSTALLATION TO ENSURE PROPER ALIGNMENT AT SPLICE BUTT JOINTS.

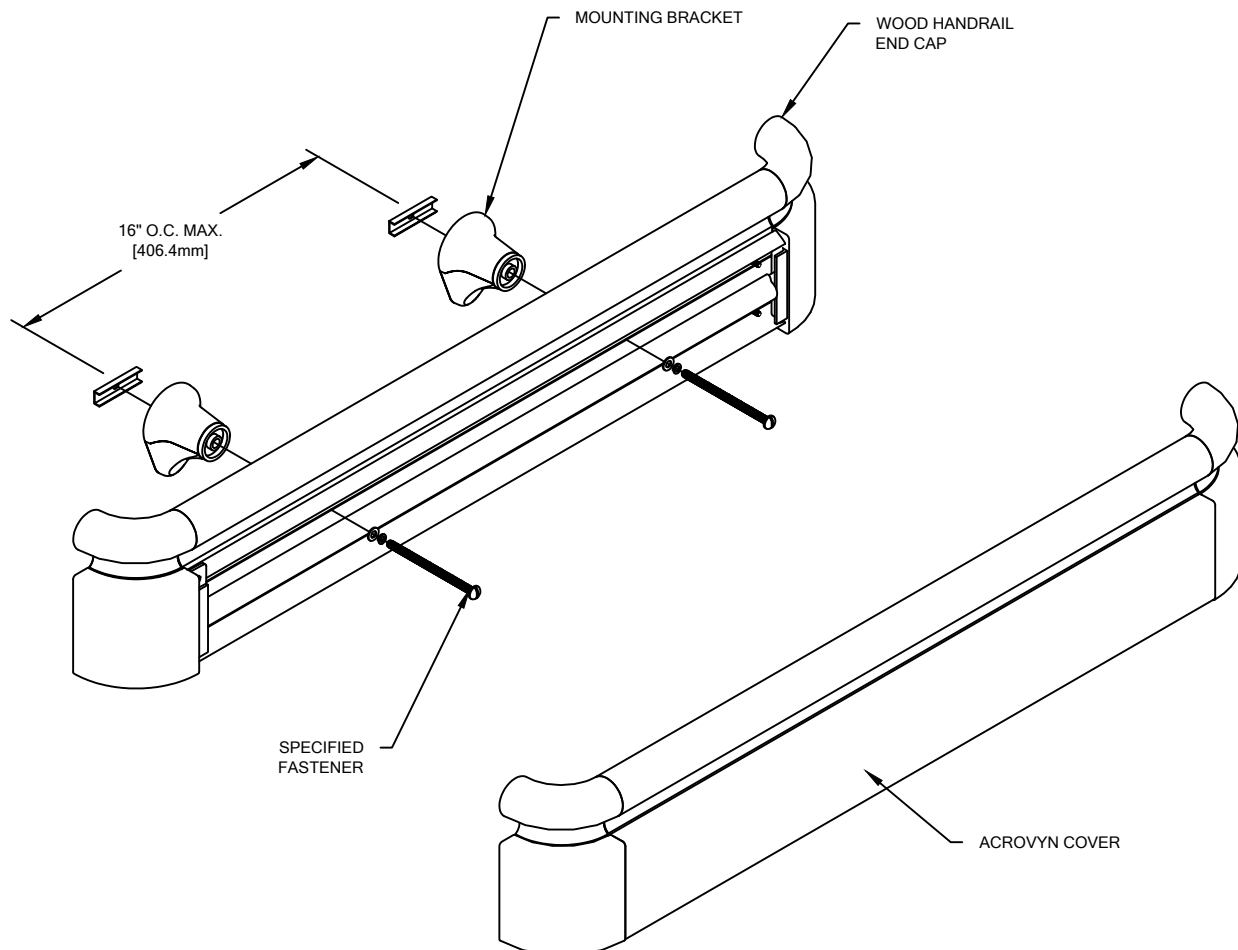

**HRBW-10CHLN HANDRAIL**

OUTSIDE CORNER ASSEMBLY

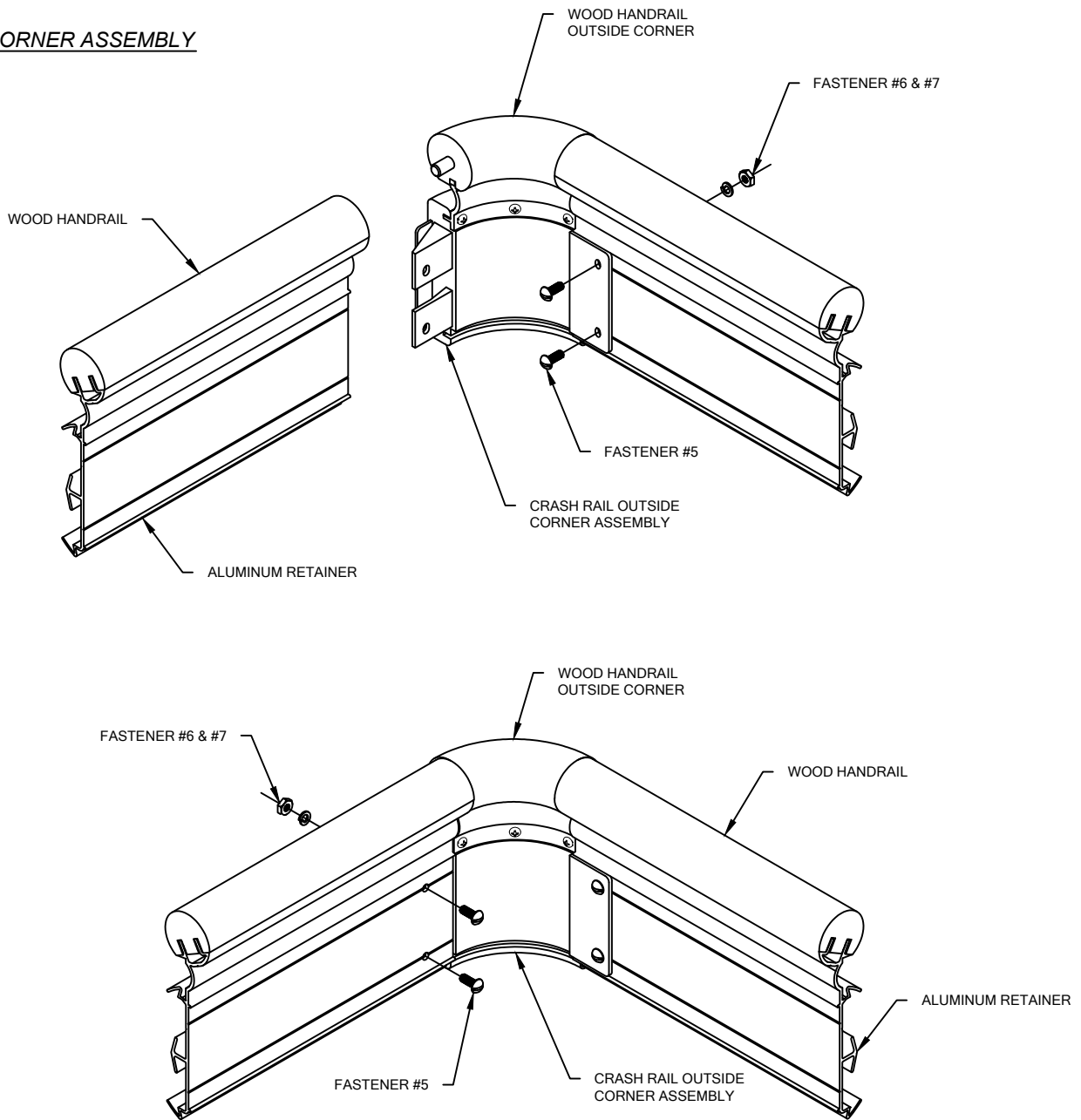

OUTSIDE CORNER INSTALLATION

1. ATTACH ALL OUTSIDE CORNERS:
  - A. ATTACH CRASH RAIL PORTION OF OUTSIDE CORNER TO THE RETAINER:
    - USE OUTSIDE CORNER AS TEMPLATE TO DRILL 7/32" PILOT HOLES IN RETAINER.
    - ATTACH OUTSIDE CORNERS BY SLIDING THE CORNER ONTO THE END OF THE ALUMINUM RETAINER AND SECURING INTO POSITION USING FOUR (4) #10-24 X 1/2" RD HD SLOTTED MACHINE SCREW WITH LOCK WASHER AND #10 HEX NUT AT EACH OUTSIDE CORNER
  - B. ATTACH HANDRAIL PORTION OF OUTSIDE CORNER TO THE RETAINER.
    - SLIDE END CAP DOWEL INTO THE ALIGNMENT HOLE IN THE RAIL.
    - WOOD GLUE MUST BE APPLIED TO THE DOWEL PRIOR TO INSERTION. APPLY HOT MELT (NO SUPPLIED) ON THE REVERSE SIDE OF THE END CAP WHERE ADAPTER FITS INTO THE BOTTOM GROOVE OF THE TOP CAP.

**NOTE:** TO AID IN LOCATING THE OUTSIDE CORNERS CORRECTLY, CUT A 4" [101.6mm] SECTION OF COVER FROM SCRAP AND SNAP IT ON THE RETAINER. LOCATE THE CORNER SO IT ALIGNS FLUSH WITH THE TOP AND BOTTOM OF THE COVER.

**NOTE:** SOLID PORTION OF OUTSIDE CORNER FLANGE MOUNTS TO THE BACK OF THE RETAINER WHILE THE SPLIT FLANGE MOUNTS TO THE INSIDE OF THE RETAINER. SEE ILLUSTRATION ABOVE.

**HRBW-10CHLN HANDRAIL**

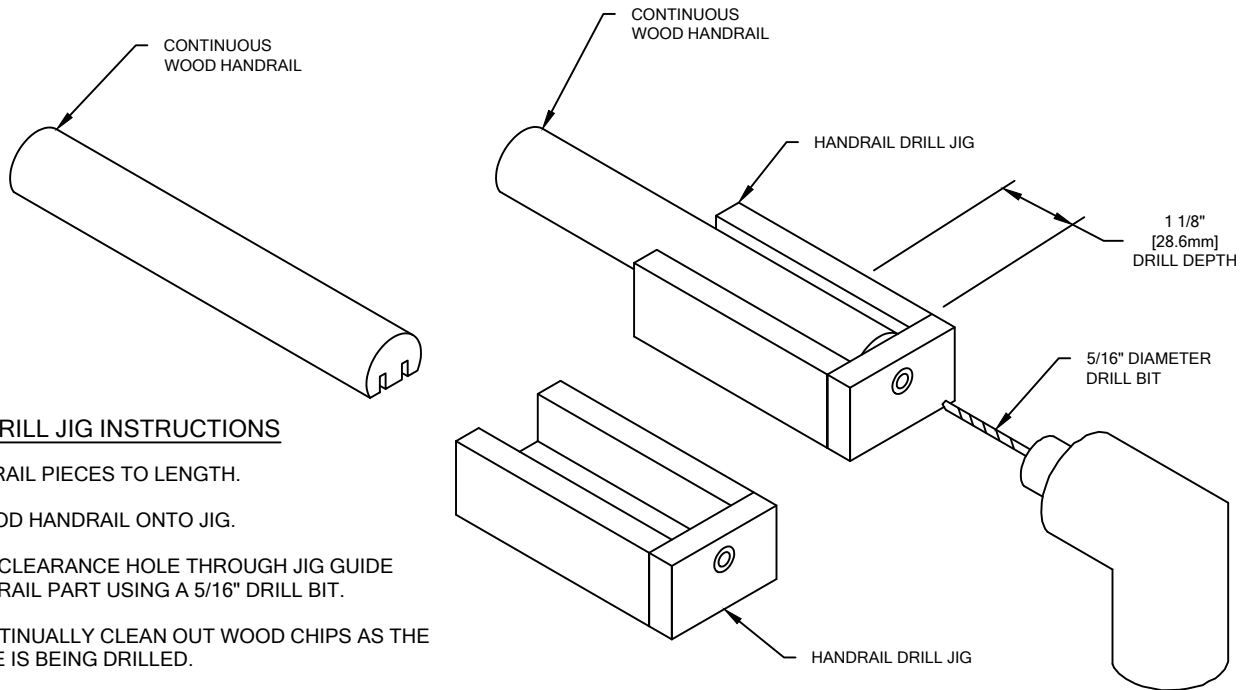

**HANDRAIL DRILL JIG INSTRUCTIONS**

1. CUT HANDRAIL PIECES TO LENGTH.
2. PLACE WOOD HANDRAIL ONTO JIG.
3. PRE-DRILL CLEARANCE HOLE THROUGH JIG GUIDE INTO HANDRAIL PART USING A 5/16\"

NOTE: CONTINUALLY CLEAN OUT WOOD CHIPS AS THE PILOT HOLE IS BEING DRILLED.

4. BEVEL FIELD CUT EDGES OF ALL WOOD COMPONENTS AND TOUCH THEM UP USING ENCLOSED STAIN PENCIL.

**CHAMELEON REVEAL INSTALLATION**

**END CAPS**

1. LOOSEN THE #6 x 3/8\"
2. SLIDE THE CHAMELEON END CAP REVEAL OVER THE INSTALLED END CAP ADAPTER. BE SURE TO PLACE THE LONG LEG OF THE CHAMELEON REVEAL AT THE TOP.
3. TIGHTEN THE (3) THREE #6 x 3/8\"

**HANDRAIL**

1. CUT CHAMELEON ACCENT REVEAL TO LENGTH AND INSERT INTO SLOT PROVIDED IN THE TOP SECTION OF THE ALUMINUM RETAINER ON TOP OF PREVIOUSLY INSTALLED STANDARD REVEAL.

