

## HRW-32A-INT HANDRAIL

### PLEASE READ

PLEASE READ THESE INSTRUCTIONS THOROUGHLY PRIOR TO BEGINNING THE HRW-32A-INT HANDRAIL INSTALLATION!

THIS INSTRUCTION SHEET IS INTENDED TO PROVIDE A SPECIFIC GUIDE TO FOLLOW FOR THE INSTALLATION OF HRW-32A-INT HANDRAIL. CONTAINED WITHIN IS THE TECHNICAL INFORMATION AND INSTALLATION TECHNIQUES REQUIRED TO COMPLETE AN EFFICIENT, NEAT AND LONG-LASTING INSTALLATION.

INSPECT ALL MATERIALS FOR DAMAGE OR MISSING PARTS. IF YOU DISCOVER DAMAGED OR MISSING MATERIALS, IN THE USA PLEASE NOTIFY THE FACTORY AT (800) 233-8493, AND IN CANADA (888) 895-8955.

HRW-32A-INT HANDRAIL MUST BE INSTALLED IN ACCORDANCE WITH THESE INSTRUCTIONS! FAILURE TO FOLLOW THESE INSTRUCTIONS MAY VOID ANY PRODUCT WARRANTIES AND RESULT IN AN UNSUCCESSFUL INSTALLATION. FOR SPECIFIC QUESTIONS REGARDING THE INSTALLATION OF HRW-32A-INT HANDRAIL PLEASE CALL THE FACTORY AT (800) 233-8493 OR EMAIL [IWPTECHSUPPORT@C-SGROUP.COM](mailto:IWPTECHSUPPORT@C-SGROUP.COM). IN CANADA CALL (888) 895-8955.

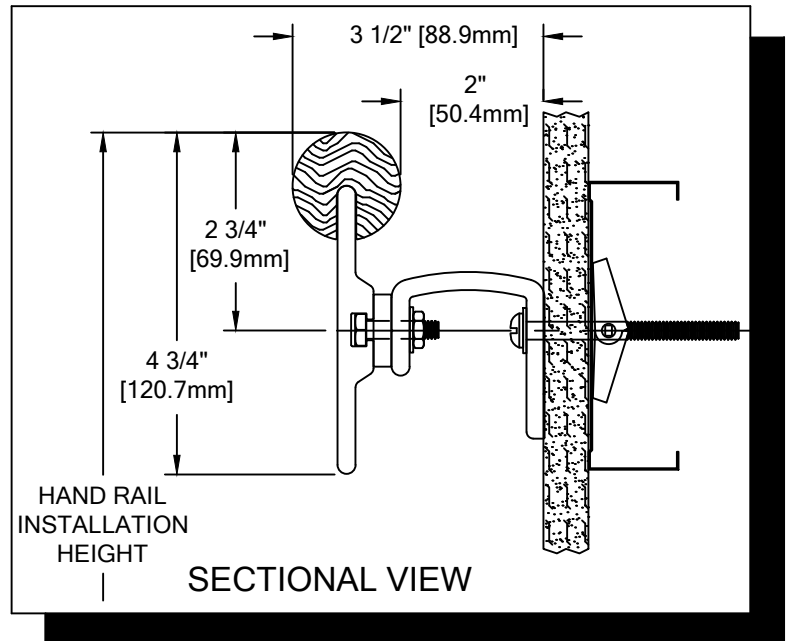

### IMPORTANT NOTES

1. DUE TO THE NATURE OF WOOD, COMPONENT COLORS MAY VARY. SORT WOOD COMPONENTS AND MATCH PARTS BY COLOR.
2. THIS MATERIAL HAS BEEN MANUFACTURED TO CUSTOMER SPECIFIED DIMENSIONS AND CAN NOT BE CUT OR MODIFIED ON SITE. TO DO SO COULD VOID WARRANTY.
3. RADIAL MATERIAL MAY BE SUPPLIED FACTORY FORMED OR IN STRAIGHT LENGTHS FOR FIELD FORMING. CONSULT FACTORY FOR OPTIONS.
4. ALL DIMENSIONS ARE TYPICAL.
5. FOR DRYWALL/PLASTER WALL CONSTRUCTION, IT IS RECOMMENDED FOR FASTENERS TO BE ENGAGED INTO METAL/WOOD STUDS TO MAINTAIN MAXIMUM PULLOUT STRENGTH. IF DURING INSTALLATION YOU ENCOUNTER SPECIAL WALL CONDITIONS THAT DO NOT ALLOW FOR DIRECT ATTACHMENT TO THE STUDS PLEASE CONSULT THE LOCAL AUTHORITY HAVING JURISDICTION.
6. MATERIAL MUST REACH 65°F MIN. TO 75°F MAX. 24 HOURS PRIOR TO INSTALLATION. THIS IS ESSENTIAL TO MINIMIZE EXPANSION AND CONTRACTION OF MATERIAL.
7. MAY REQUIRE USE OF FIRE PUTTY WHEN INSTALLED ON FIRE WALL WITH TOGGLE BOLTS.
8. THIS HANDRAIL REQUIRES A MINIMUM OF 2 MOUNTING BRACKETS PER UNIT. THE MINIMUM END CAP-TO-END CAP HANDRAIL LENGTH IS 13\" [330.2mm].

HRW-32A-INT HANDRAIL

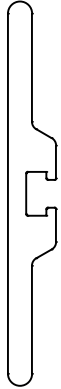

ALUMINUM CRASH RAIL  
(24A241000)

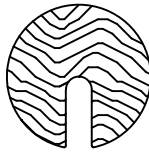

WOOD HANDRAIL  
(24W290xxx)

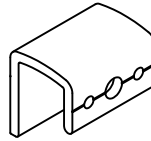

MOUNTING BRACKET  
(24F181003)

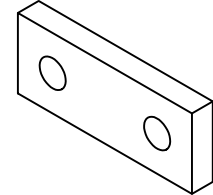

BRACKET EXTENSION  
(24F423001)

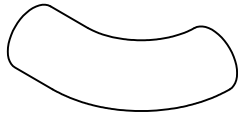

HANDRAIL END CAP  
(24W292xxx-RH)  
(24W291xxx-LH)



FASTENER #2  
1/4" FLAT WASHER  
(90H007003)



FASTENER #3  
1/4-20 HEX NUT  
(90H010001)

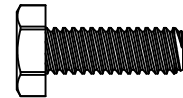

FASTENER #1  
1/4-20 X 3/4"  
HEX HEAD  
MACHINE SCREW  
(90H008002)

WALL CONDITION	SPECIFIED FASTENER	DRILL DIAMETERS		CS PART NUMBER
		WALL	RETAINER	
STEEL STUD/GYPSUM WALL	1/4-20 X 3" ROUND HEAD BOLT/TOGGLE WING	3/4"	N/A	90H045002
CONCRETE/CONCRETE BLOCK	#14 X 4" SS PHILLIPS ROUND HEAD ALL-PURPOSE SCREW	7/32"	N/A	90H225006
WOOD STUD/GYPSUM WALL	#14 X 4" SS PHILLIPS ROUND HEAD ALL-PURPOSE SCREW	7/32"	N/A	90H225006

HRW-32A-INT HANDRAIL

LAYOUT VIEW

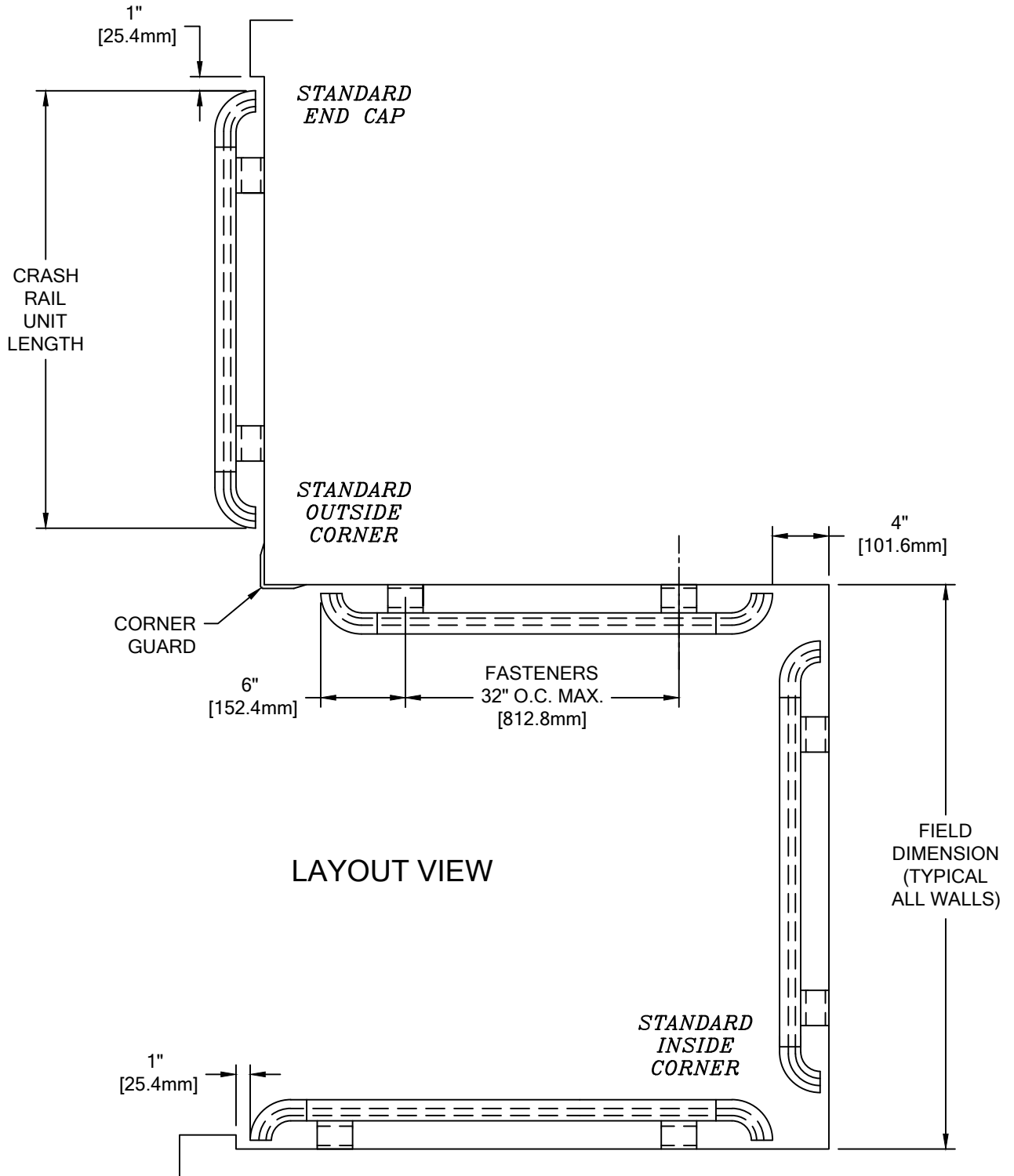

LAYOUT VIEW

**HRW-32A-INT HANDRAIL**

TYPICAL ASSEMBLY

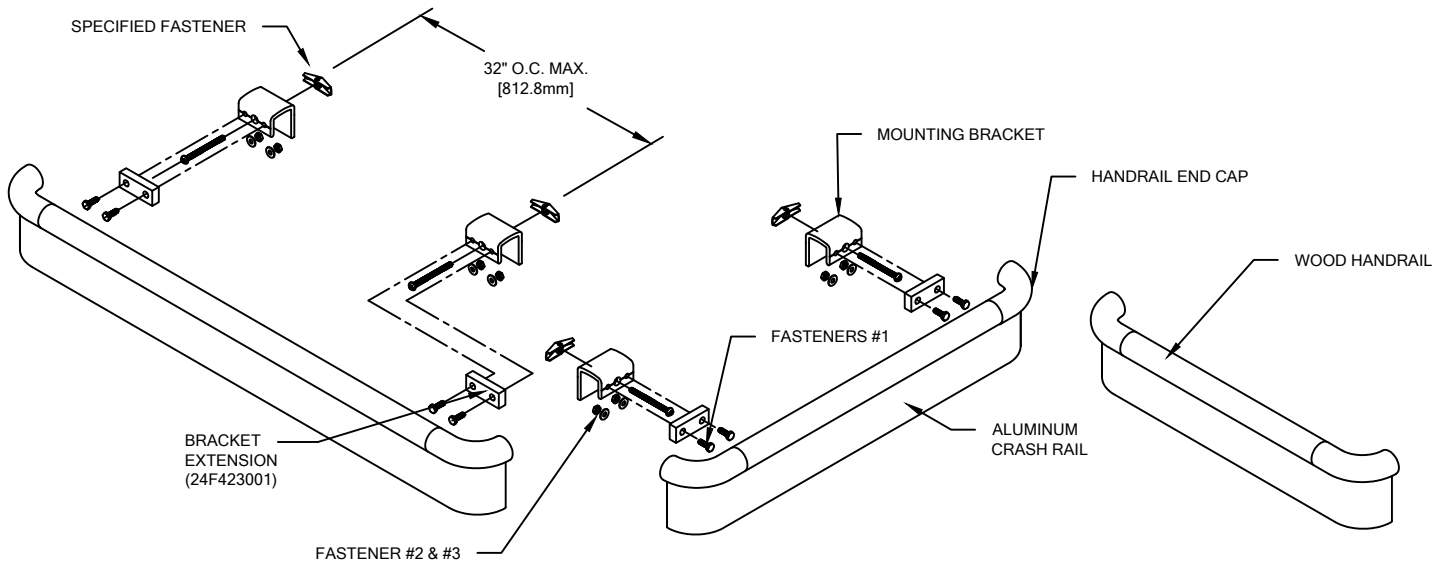

**NOTE:** INSTALLATION OF LINEAL OR RADIAL HRW-32A HANDRAIL SHOULD BE DONE IN ACCORDANCE WITH THE FOLLOWING INSTRUCTIONS.

1. USE LOCAL CODE REQUIREMENTS AND ESTABLISH HANDRAIL HEIGHT ABOVE FINISH FLOOR. DEDUCT 2 3/4" [69.8mm] AND SNAP A CHALK LINE AT THAT HEIGHT. THIS MARKS THE LOCATION OF THE MOUNTING BRACKET FASTENERS.
2. DETERMINE WALL FASTENER LOCATIONS BY USING THE REQUIRED DEDUCTIONS (SEE LAYOUT VIEW) AND DRILL HOLE DIAMETER (REFERENCE CHART BELOW LAYOUT VIEW) IN THE WALL FOR SPECIFIED WALL FASTENERS (SEE NOTE 2 ON LAYOUT VIEW).
3. INSTALL MOUNTING BRACKETS USING APPROPRIATE FASTENERS. LEVEL EACH MOUNTING BRACKET WHILE FASTENING IT TO THE WALL.
4. SLIDE TWO 1/4-20 X 3/4" HEX HEAD BOLTS INTO THE RECEIVER SLOT OF THE CRASH RAIL FOR ALL WALL BRACKETS.
5. APPLY WOOD GLUE INTO THE HOLES AND CUT SURFACE OF HANDRAIL (TITEBOND IS RECOMMENDED). ATTACH HANDRAIL BY SLIDING THE END CAP DOWEL INTO THE MATING WOOD HANDRAIL CLEARANCE HOLE. WIPE OFF ANY EXCESS GLUE.
6. ATTACH THE ASSEMBLED HANDRAIL TO THE WALL BRACKETS BY ALIGNING THE HEX HEAD BOLTS WITH THE MOUNTING BRACKETS AND THE BRACKET EXTENSIONS, AND INSERTING THE HEX HEAD BOLT INTO THE MOUNTING BRACKET HOLE. PLACE A 1/4" FLAT WASHER AND 1/4-20 HEX NUT ONTO THE HEX HEAD BOLT AND TIGHTEN AS REQUIRED.

**NOTE:** WHEN FIELD FORMING RADIUS HANDRAIL, BE SURE TO APPLY NEEDED PRESSURE FROM BRACKET TO BRACKET.