

1-1/8" STAINLESS STEEL GRIDLINE II (RADIUSED RAILS) WITH RECESSED LEVEL BASE FRAME / WITH ALUMINUM DRAIN PAN			
INSERT STYLE: N/A	INSERT COLOR: N/A	CATALOG NUMBER: G6	PART NUMBER:
NO.	REVISION	DATE	BY
NO.	F&F RELEASE	DATE	BY

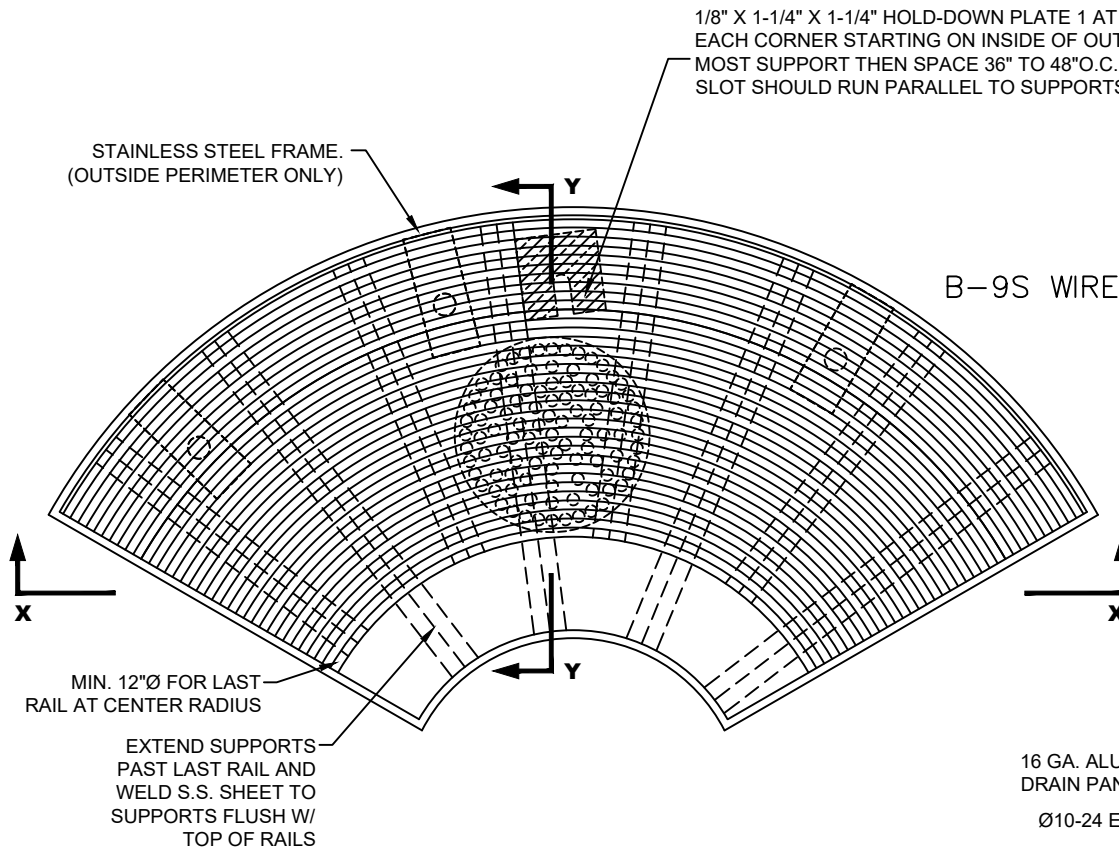

TYPICAL MODULE PLAN VIEW
NOT TO SCALE

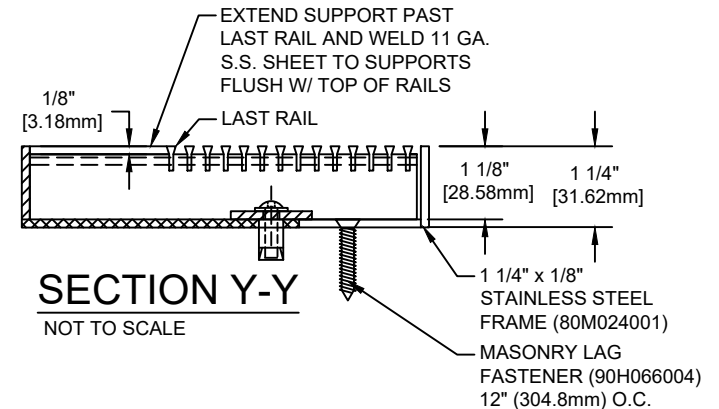

SECTION Y-Y
NOT TO SCALE

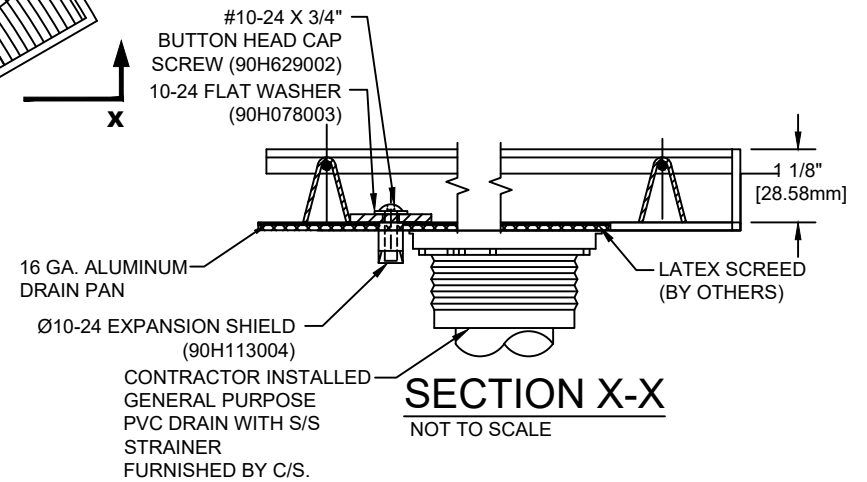

SECTION X-X
NOT TO SCALE

NOTES:

*ALL SURFACE WIRES AND SUPPORT BARS ARE ELECTRONICALLY RESISTANCE WELDED TO ENSURE CORRECT WEIGHT BEARING PROPERTIES.

*GRIDS SHALL BE ABLE TO SUPPORT A 500LB ROLLING LOAD.
* SURFACE WIRE SPACING PROVIDES A 57.7% EFFECTIVE OPEN AREA FOR DIRT AND MOISTURE REMOVAL.

CS Construction Specialties
6696 Route 405 Highway, Muncy PA 17756
(800) 233-8493 • Fax (570) 546-4692 • www.c-sgroup.com

PLEASE VERIFY ALL	QTY	MARK #	LOCATION	MODEL	DIM 'A' WIDTH	DIM 'B' LENGTH	REMARKS

PROJECT:		
LOCATION:		
CONTRACTOR:		
AGENT:		SHT:
DRG. BY:	DATE:	JOB NO.: