

HRB-20N HANDRAIL

PLEASE READ

PLEASE READ THESE INSTRUCTIONS THOROUGHLY PRIOR TO BEGINNING THE HRB-20N HANDRAIL INSTALLATION!

THIS INSTRUCTION SHEET IS INTENDED TO PROVIDE A SPECIFIC GUIDE TO FOLLOW FOR THE INSTALLATION OF THIS HRB-20N HANDRAIL. CONTAINED WITHIN IS THE TECHNICAL INFORMATION AND INSTALLATION TECHNIQUES REQUIRED TO COMPLETE AN EFFICIENT, NEAT AND LONG-LASTING INSTALLATION.

INSPECT ALL MATERIALS FOR DAMAGE OR MISSING PARTS. IF YOU DISCOVER DAMAGED OR MISSING MATERIALS, IN THE USA PLEASE NOTIFY THE FACTORY AT (800) 233-8493, AND IN CANADA (888) 895-8955 FOR CUSTOMER SERVICE.

HRB-20N HANDRAIL MUST BE INSTALLED IN ACCORDANCE WITH THESE INSTRUCTIONS! FAILURE TO FOLLOW THESE INSTRUCTIONS MAY VOID ANY PRODUCT WARRANTIES AND RESULT IN AN UNSUCCESSFUL INSTALLATION. FOR SPECIFIC QUESTIONS REGARDING THE INSTALLATION OF THIS HRB-20N HANDRAIL PLEASE CALL THE FACTORY IN THE USA AT (800) 233-8493 OR EMAIL IWPTECHSUPPORT@C-SGROUP.COM. IN CANADA CALL (888) 895-8955.

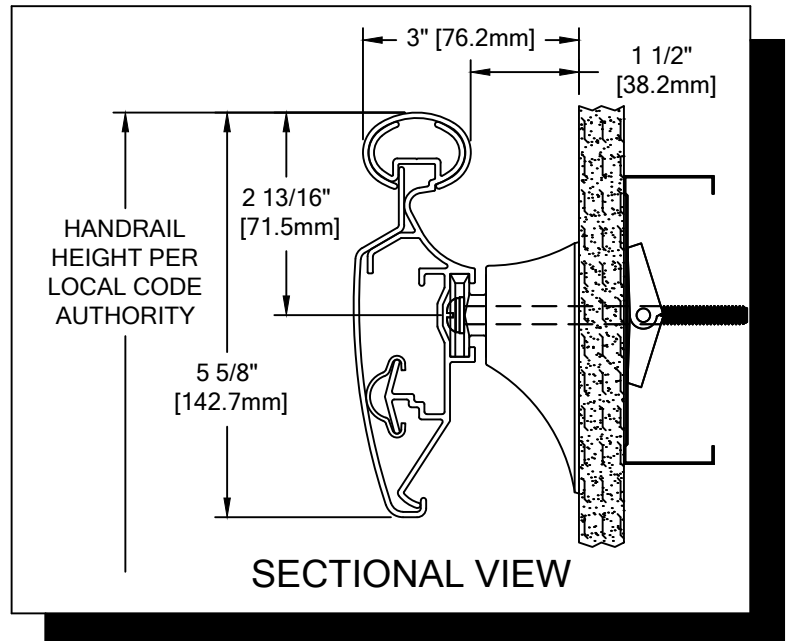

IMPORTANT NOTES

1. ALL LINEAL MATERIAL TO BE SUPPLIED IN STOCK LENGTHS. ALUMINUM AND ACROVYN IN LENGTHS UP TO 20'-0". THIS MATERIAL IS TO BE FIELD CUT USING QUALITY EQUIPMENT TO INSURE THAT ALL CUTS ARE SQUARE. WHEN CUTTING MATERIAL SECTIONS, CS RECOMMENDS USING AN 80-100 TOOTH CARBIDE TIPPED SAW BLADE OR EQUIVALENT, TO MINIMIZE CHIPPING AND MAINTAIN JOINT ALIGNMENT.
2. RADIAL MATERIAL MAY BE SUPPLIED FACTORY FORMED OR IN STRAIGHT LENGTHS FOR FIELD FORMING. CONSULT FACTORY FOR OPTIONS.
3. ALL DIMENSIONS ARE TYPICAL.
4. FOR DRYWALL/PLASTER WALL CONSTRUCTION, IT IS RECOMMENDED FOR FASTENERS TO BE ENGAGED INTO METAL/WOOD STUDS TO MAINTAIN MAXIMUM PULLOUT STRENGTH. IF DURING INSTALLATION YOU ENCOUNTER SPECIAL WALL CONDITIONS THAT DO NOT ALLOW FOR DIRECT ATTACHMENT TO STUDS PLEASE CONSULT THE LOCAL AUTHORITY HAVING JURISDICTION.
5. INSTALL OUTSIDE CORNERS FIRST.
6. INSTALL LONGEST RUN OF HANDRAIL FIRST.
7. ALUMINUM RETAINER SPLICE SHOULD NOT EXCEED 4" [101.6mm] DISTANCE FROM A BRACKET.
8. THE DISTANCE BETWEEN AN ACROVYN SPLICE JOINT AND AN ALUMINUM RETAINER SPLICE JOINT SHOULD BE STAGGERED 4" [101.6mm].
8. TANGENT POINTS ON FACTORY FORMED RADIAL MATERIAL WILL BE MARKED APPROXIMATELY AND SHOULD BE CUT TO SUIT FIELD CONDITIONS.
9. MATERIAL MUST REACH 65°F MIN. TO 75°F MAX. 24 HOURS PRIOR TO INSTALLATION. THIS IS ESSENTIAL TO MINIMIZE EXPANSION AND CONTRACTION OF MATERIAL.
10. MAY REQUIRE USE OF FIRE PUTTY WHEN INSTALLED ON FIRE WALL WITH TOGGLE BOLTS. REFERENCE INSTRUCTIONS 24FIREPUTTY FOR FIRE PUTTY INSTALLATION
11. THIS HANDRAIL REQUIRES A MINIMUM OF 2 MOUNTING BRACKETS PER UNIT. THE MINIMUM END CAP-TO-END CAP HANDRAIL LENGTH IS 17" [431.8mm].
12. FOR MORE INFORMATION ON HRB-20N HANDRAIL SEE OUR WEBSITE AT www.c-sgroup.com.

HRB-20N HANDRAIL

COMPONENTS & WALL FASTENERS



ACROVYN HANDRAIL COVER
(24U800xxx)
ACROVYN CHAMELEON COVER
(24U934xxx)



RC-10 CUSHION
(24U952108)



ALUMINUM RETAINER
(24A289000)



ACROVYN CRASH RAIL COVER
(24U801xxx)
ACROVYN CHAMELEON COVER
(24U940xxx)



QUICK LOCK
(24I821000)
METAL QUICK LOCK
FOR OSHPD
(24M068000)



OPTIONAL
HANDRAIL REVEAL
(24I835xxx)

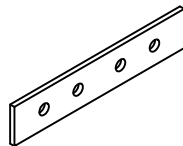

RETAINER SPLICE BAR
(24I976000)

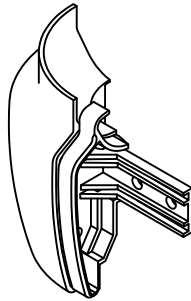

CRASH RAIL ENDCAP
(24I117xxx, LH SHOWN)
(24I118xxx, RH)
CHAMELEON ENDCAP
(24I989xxx, LH SHOWN)
(24I990xxx, RH)

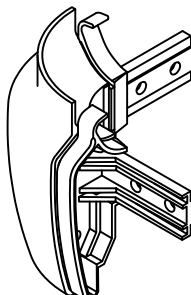

CRASH RAIL OUTSIDE
CORNER ASSEMBLY

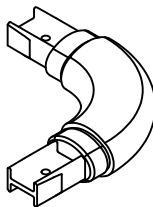

HANDRAIL OUTSIDE
CORNER ASSEMBLY

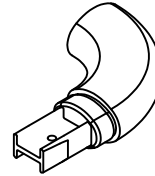

HANDRAIL ENDCAP
(24I840xxx, RH SHOWN)
(24I841xxx, LH)
CHAMELEON END CAP
(24I992xxx, RH SHOWN)
(24I991xxx, LH)

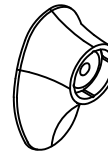

MOUNTING BRACKET
(24I820xxx)



OPTIONAL
CRASH RAIL REVEAL
(24I834xxx)

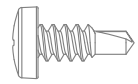

FASTENER #1
#10 X 1/2" PHILLIPS
PANCAKE HD TEK SCREW
(90H083002)

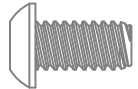

FASTENER #2
1/4-20 X 1/2" BUTTON
SOCKET HEAD CAP SCREW
(90H772002)



FASTENER #3
1/4" LOCK WASHER
(90H006003)



FASTENER #4
1/4-20 HEX NUT
(90H010001)

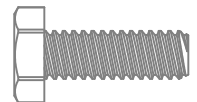

FASTENER #5
1/4-20 X 3/4"
HEX HEAD MACHINE SCREW
(90H008002)

WALL CONDITION	SPECIFIED FASTENER	DRILL DIAMETERS		CS PART NUMBER
		WALL	RETAINER	
STEEL STUD/GYPSUM WALL	1/4-20 X 5" ROUND HEAD BOLT WITH TOGGLE, AND LOCK WASHER	3/4"	N/A	90H049002 90H006003
CONCRETE/CONCRETE BLOCK	#14 X 5" PHILLIPS RD HD ALL-PURPOSE SCREW	3/16"	N/A	90H287002
WOOD STUD/GYPSUM WALL	#14 X 5" PHILLIPS RD HD ALL-PURPOSE SCREW	1/8"	N/A	90H287002
20 GA. STEEL STUD/GYPSUM WALL (OSHPD)	1/4-20 X 5" RD. HD. BOLT WITH FLAT WASHER 1/4" TOGGLER WING 3M MOLDABLE FIRE PUTTY	1/2"	N/A	90H659002 90H007003 90H062004 90M012000
16 GA. MIN. STEEL STUD AND 16 GA. MIN. STEEL STRAPPING / GYPSUM WALL CONSTRUCTION REQUIRED (TEK SCREWS)	#14 X 5" PHILLIPS PAN HEAD #3 SELF DRILLING TEK SCREW ZINC PLATED	N/A	N/A	90H286001

HRB-20N HANDRAIL

LAYOUT VIEW

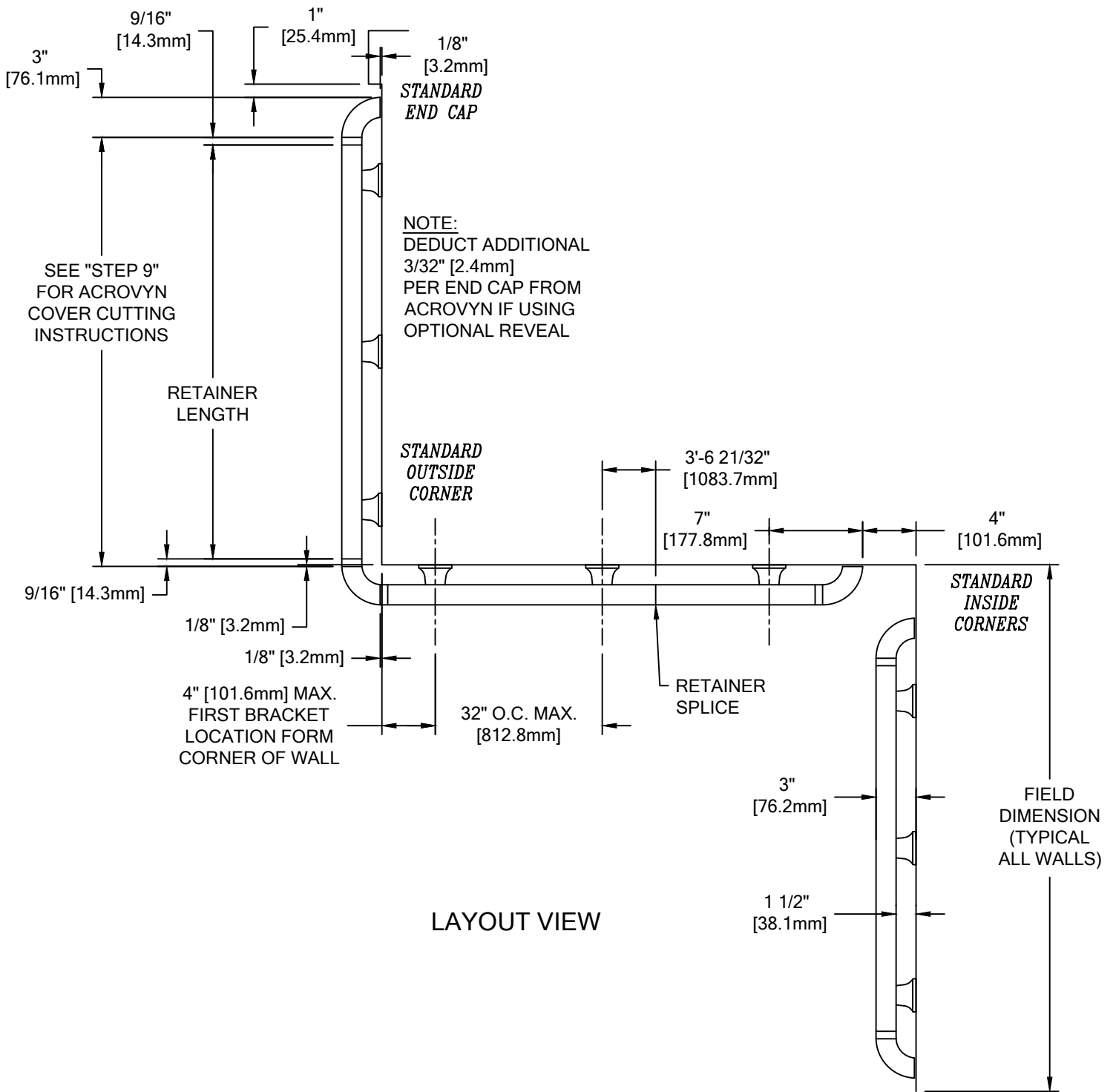

HRB-20N HANDRAIL

TYPICAL ASSEMBLY

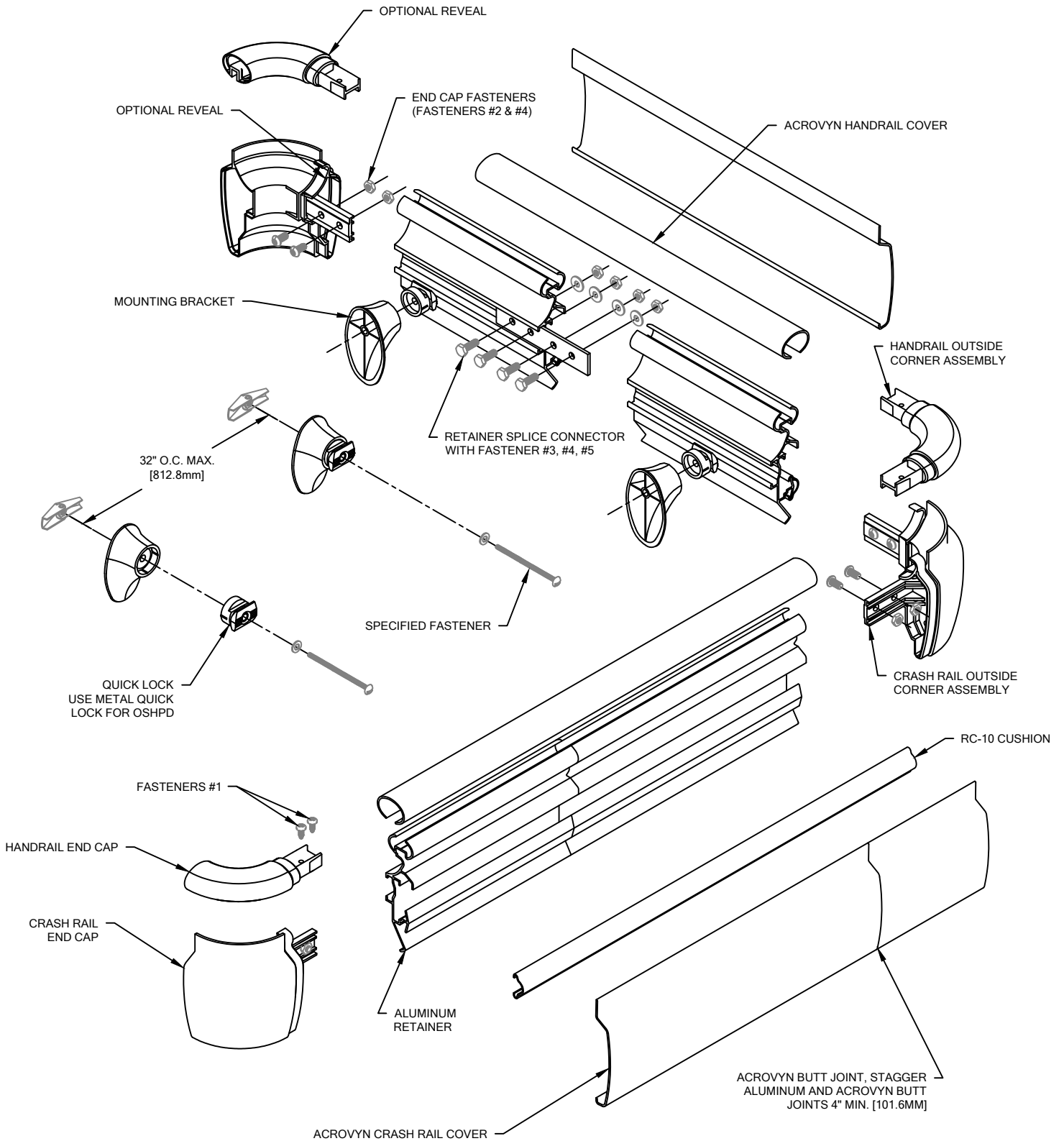

HRB-20N HANDRAIL

NOTE: INSTALLATION OF LINEAL OR RADIAL HRB-20N HANDRAIL SHOULD BE DONE IN ACCORDANCE WITH THE FOLLOWING INSTRUCTIONS.

1. ESTABLISH HANDRAIL HEIGHT ABOVE FINISH FLOOR. DEDUCT 2 13/16" [71.4mm] AND SNAP A CHALK LINE AT THAT HEIGHT. THIS MARKS THE LOCATION OF THE FASTENERS FOR THE HANDRAIL BRACKETS.
2. DETERMINE WALL FASTENER LOCATIONS BY USING THE REQUIRED DEDUCTIONS (SEE LAYOUT VIEW) AND DRILL HOLE DIAMETER FOR SPECIFIED WALL FASTENERS. REFERENCE CHART ON PAGE 2 FOR CORRECT DRILL DIAMETERS.
3. PLACE A QUICK LOCK INTO EACH BRACKET BASE. USING THE APPROPRIATE FASTENERS, ATTACH THE BRACKET ASSEMBLIES TO THE WALL AT THE PRE-DRILLED LOCATIONS. SEE ILLUSTRATION 1. DO NOT OVER TORQUE FASTENERS.

NOTE: IF YOUR ORDER IS A CUT-TO-SIZE JOB, GO TO STEP 5.

NOTE: IF YOUR ORDER IS A PRE-ASSEMBLED JOB, GO TO STEP 5.

4. CUT THE CONTINUOUS ALUMINUM RETAINER TO LENGTH USING THE REQUIRED DEDUCTIONS AS NOTED (SEE LAYOUT VIEW).

NOTE: IT IS RECOMMENDED THAT THE ACROVYN COVERS AND ALUMINUM RETAINER BE CUT WITH AN 80-100 TOOTH CARBIDE TIPPED SAW BLADE OR EQUIVALENT.

5. CUT RC-10 CUSHION TO LENGTH NOTING REQUIRED DEDUCTIONS (SEE LAYOUT VIEW) AND INSTALL ONTO ALUMINUM RETAINER.

OPTIONAL: THE END CAPS AND COVERS MAY BE INSTALLED ONTO THE RETAINER FIRST, AND THE ASSEMBLY PLACED ONTO THE BRACKETS AS A COMPLETE UNIT AND THEN LOCKED INTO PLACE.

6. PLACE THE RETAINER ON THE WALL BRACKETS SO THAT THE HEAD OF EACH QUICK LOCK INSERTS INTO THE CHANNEL ON THE BACK OF THE RETAINER. USING THE WRENCH PROVIDED, TWIST EACH LOCK 90° TO SECURE THE BRACKET BASE INTO PLACE. SEE ILLUSTRATIONS 1 THROUGH 4. USE A LEVEL TO ENSURE RETAINER IS LEVEL.

NOTE: WHEN FIELD FORMING RADIUS HANDRAIL, BE SURE TO APPLY NEEDED PRESSURE FROM BRACKET TO BRACKET.

7. ATTACH END CAPS/OR CORNER ASSEMBLIES BY LOOSELY THREADING TWO (2) 1/4-20 X 1/2" BUTTON SOCKET HEAD CAP SCREWS THROUGH THE BACKSIDE OF THE FLANGE OF EACH END CAP (FOUR (4) PER CORNER ASSEMBLY) INTO THEIR RESPECTIVE NUTS ON THE RETAINER SIDE OF THE FLANGE. SLIDE THE FLANGE INTO THE RECEIVER CHANNEL OF THE ALUMINUM RETAINER AND TIGHTEN THE BUTTON SOCKET HEAD CAP SCREWS FOR A SECURE FIT. SEE ILLUSTRATIONS 5 THROUGH 7.
8. ATTACH HANDRAIL END CAP TO RETAINER WITH TWO (2) #10 X 1/2" PHILLIPS PAN HEAD TEK SCREWS.
 - 8.1. INSERT END CAP INTO RETAINER.
 - 8.2. DRILL 1/8" DIAMETER PILOT HOLES THROUGH THE TOP OF THE RETAINER AND END CAP, 7/8" [22.2mm] AND 1 9/16" [39.7mm] FROM THE END OF THE RETAINER.
 - 8.3. REMOVE END CAP AND DRILL 11/64" CLEARANCE HOLES FOR THE #10 X 1/2" PHILLIPS PAN HEAD SCREW.
 - 8.4. ATTACH END CAP TO RETAINER WITH ABOVE MENTIONED SCREWS.

NOTE: TO AID IN LOCATING THE END CAPS CORRECTLY, CUT A 4" [101.6mm] SECTION OF COVER FROM SCRAP AND SNAP IT ON THE RETAINER. LOCATE THE CAP SO IT ALIGNS FLUSH WITH TOP AND BOTTOM OF THE COVER.

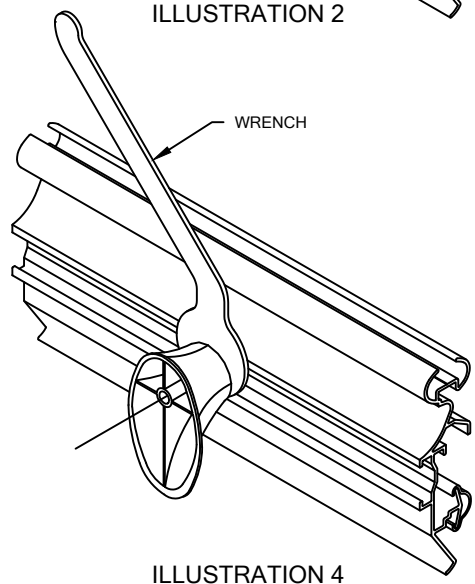
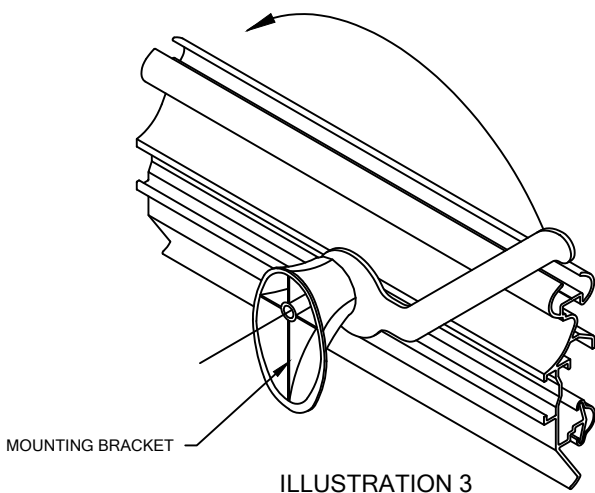
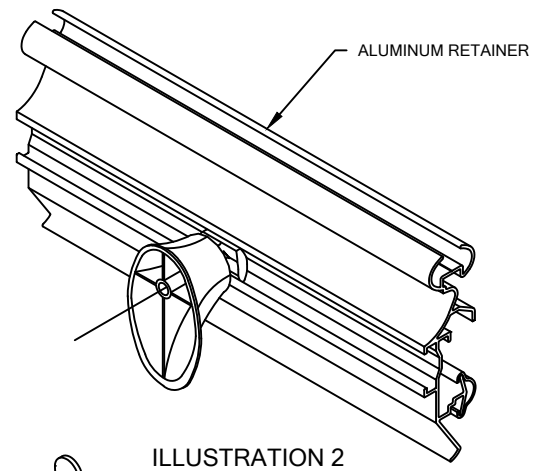
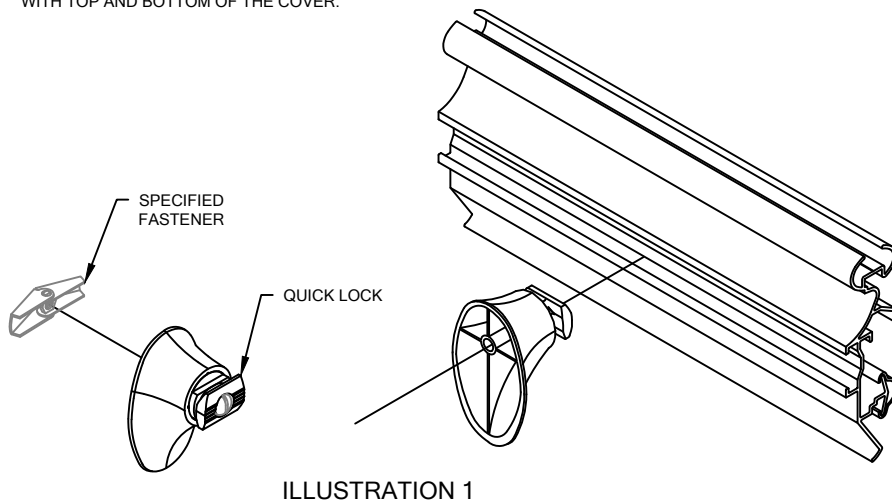

HRB-20N HANDRAIL

- CUT THE ACROVYN COVERS TO THE PROPER LENGTH. THE COVER LENGTH IS DETERMINED BY MEASURING THE DISTANCE BETWEEN THE INSTALLED END CAPS AND/OR OUTSIDE CORNER ASSEMBLIES.

NOTE: IT IS RECOMMENDED THAT THE ACROVYN COVERS BE CUT SLIGHTLY LONGER (1/32" UP TO 5'-0", 1/16" OVER 5'-0") THAN THE MEASURED DISTANCE. THIS ADDITIONAL LENGTH WILL PROVIDE FOR A TIGHTER COVER-TO-END CAP FIT.

- SNAP THE HRB-20N ACROVYN COVER ONTO THE LOWER PORTION OF THE RETAINER. ALIGN THE TOP OF THE HANDRAIL ACROVYN COVER WITH THE TOP OF THE ALUMINUM RETAINER AND SNAP THE COVER ONTO THE RETAINER.

END CAP ATTACHMENT

ATTACH END CAPS/OUTSIDE CORNERS TO THE RETAINER BY LOOSELY THREADING TWO (2) 1/4-20 X 1/2" BUTTON SOCKET HEAD CAP SCREWS THROUGH THE BACKSIDE OF THE FLANGE OF EACH END CAP (FOUR (4) PER CORNER ASSEMBLY) INTO THEIR RESPECTIVE NUTS ON THE RETAINER SIDE OF THE FLANGE. SLIDE THE FLANGE INTO THE RECEIVER CHANNEL OF THE ALUMINUM RETAINER AND TIGHTEN THE BUTTON SOCKET HEAD CAP SCREWS FOR A SECURE FIT.

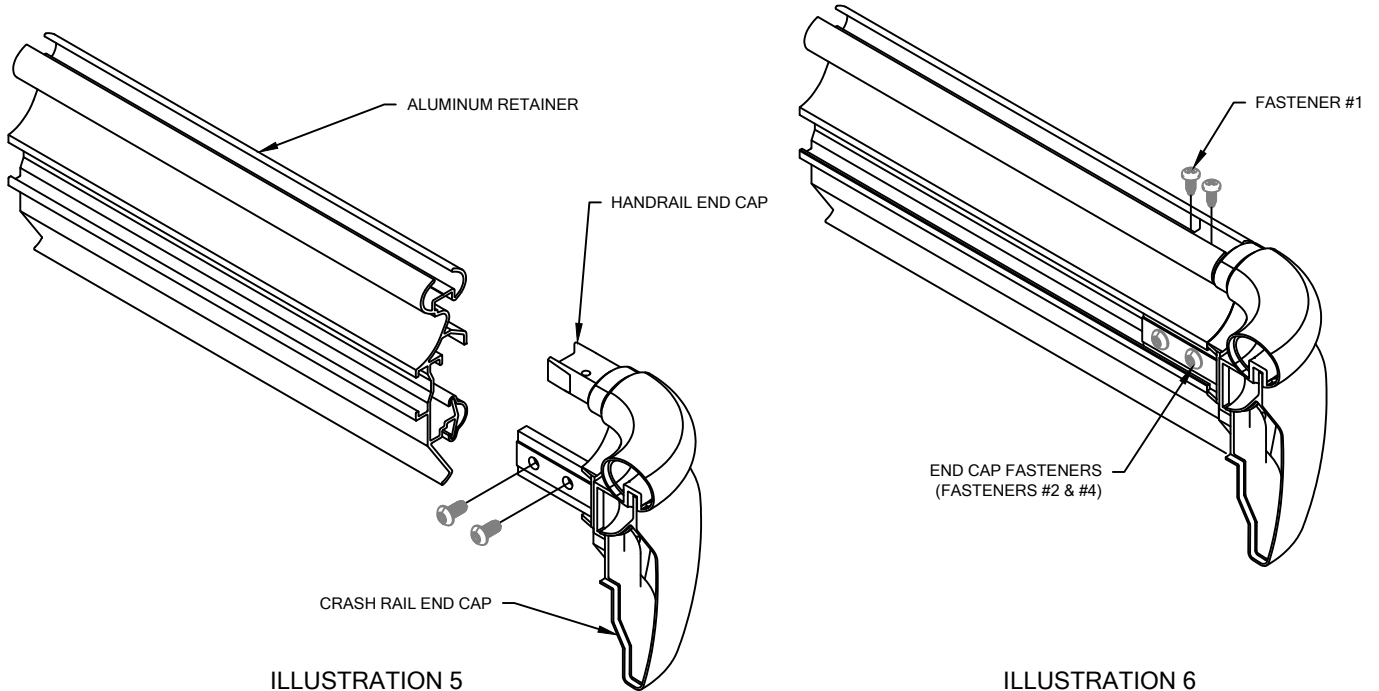

11/9/18