

**COLOR:**  
 HANDRAIL WOOD SPECIES: \_\_\_\_\_  
 HANDRAIL WOOD FINISH: \_\_\_\_\_  
 COLOR TO BE SELECTED FROM ONE OF CS STANDARD COLORS.

**FEATURE BUMPER COLOR:** \_\_\_\_\_  
 REFER TO CS CATALOG FOR FEATURE BUMPER COLORS.

TOTAL L/F REQ'D	LEFT END CAPS	RIGHT END CAPS

**NOTES:**

1. THIS MODEL IS FABRICATED CUT-TO-SIZE, THEREFORE FIELD VERIFIED DIMENSIONS ARE REQUIRED.

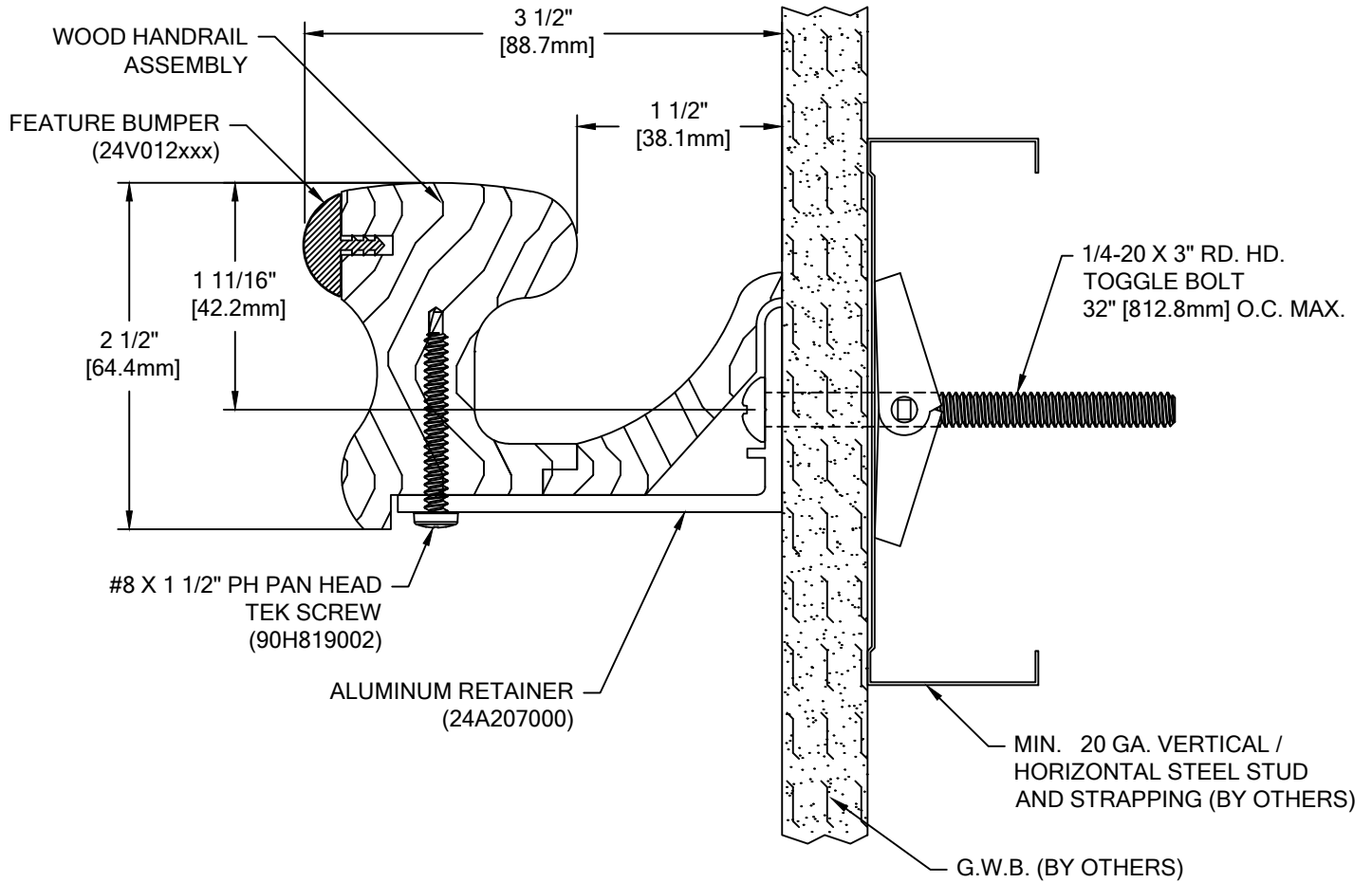

# AW-LRVB

WALL CONDITION	SPECIFIED FASTENER	DRILL DIAMETERS		CS PART NUMBER
		WALL	RETAINER	
STEEL STUD/GYPSUM WALL	1/4-20 X 3" ROUND HEAD TOGGLE BOLT	3/4"	9/32"	90H045002
CONCRETE/CONCRETE BLOCK	1/4" X 1 3/4" HEX HEAD MASONRY	3/16"	9/32"	905005004
WOOD STUD/GYPSUM WALL	1/4" X 3" HEX HEAD LAG SCREW	3/16"	9/32"	90H087002

 <p>Hughesville, PA   800.233.8493   570.546.5941        Mississauga, ON   888.895.8955   905.274.3611  <a href="http://www.c-sgroup.com">www.c-sgroup.com</a></p> <p>© Copyright 2017 Construction Specialties, Inc.</p>	<b>PROJECT:</b>	<b>REVISION:</b>
	<b>JOB NO.:</b>	<b>F&amp;F:</b>
	<b>CUSTOMER:</b>	
	<b>REP:</b>	<b>DATE:</b>
	<b>DRAWN BY:</b>	<b>SHEET NO:</b>