

**HR-6CN HANDRAIL**  
WITH INTERNATIONAL OFFSET

PLEASE READ

PLEASE READ THESE INSTRUCTIONS THOROUGHLY PRIOR TO BEGINNING THE HR-6CN HANDRAIL INSTALLATION!

THIS INSTRUCTION SHEET IS INTENDED TO PROVIDE A SPECIFIC GUIDE TO FOLLOW FOR THE INSTALLATION OF THIS HR-6CN HANDRAIL. CONTAINED WITHIN IS THE TECHNICAL INFORMATION AND INSTALLATION TECHNIQUES REQUIRED TO COMPLETE AN EFFICIENT, NEAT AND LONG-LASTING INSTALLATION.

INSPECT ALL MATERIALS FOR DAMAGE OR MISSING PARTS. IF YOU DISCOVER DAMAGED OR MISSING MATERIALS, IN THE USA PLEASE NOTIFY THE FACTORY AT (800) 233-8493, AND IN CANADA (888) 895-8955 FOR CUSTOMER SERVICE.

HR-6CN HANDRAIL MUST BE INSTALLED IN ACCORDANCE WITH THESE INSTRUCTIONS! FAILURE TO FOLLOW THESE INSTRUCTIONS MAY VOID ANY PRODUCT WARRANTIES AND RESULT IN AN UNSUCCESSFUL INSTALLATION. FOR SPECIFIC QUESTIONS REGARDING THE INSTALLATION OF THIS HR-6CN HANDRAIL PLEASE CALL THE FACTORY IN THE USA AT (800) 233-8493 OR EMAIL [IWPTECHSUPPORT@C-SGROUP.COM](mailto:IWPTECHSUPPORT@C-SGROUP.COM). IN CANADA CALL (888) 895-8955.

IMPORTANT NOTES

1. ALL LINEAL MATERIAL TO BE SUPPLIED IN STOCK LENGTHS. ALUMINUM AND ACROVYN IN LENGTHS UP TO 20'-0". THIS MATERIAL IS TO BE FIELD CUT USING QUALITY EQUIPMENT TO INSURE THAT ALL CUTS ARE SQUARE. WHEN CUTTING MATERIAL SECTIONS, CS RECOMMENDS USING AN 80-100 TOOTH CARBIDE TIPPED SAW BLADE OR EQUIVALENT, TO MINIMIZE CHIPPING AND MAINTAIN JOINT ALIGNMENT.
2. RADIAL MATERIAL MAY BE SUPPLIED FACTORY FORMED OR IN STRAIGHT LENGTHS FOR FIELD FORMING. CONSULT FACTORY FOR OPTIONS.
3. ALL DIMENSIONS ARE TYPICAL.
4. FOR DRYWALL/PLASTER WALL CONSTRUCTION, IT IS RECOMMENDED FOR FASTENERS TO BE ENGAGED INTO METAL/WOOD STUDS TO MAINTAIN MAXIMUM PULLOUT STRENGTH. IF DURING INSTALLATION YOU ENCOUNTER SPECIAL WALL CONDITIONS THAT DO NOT ALLOW FOR DIRECT ATTACHMENT TO THE STUDS, PLEASE CONSULT THE LOCAL AUTHORITY HAVING JURISDICTION.
5. INSTALL OUTSIDE CORNERS FIRST.
6. INSTALL LONGEST RUN OF HANDRAIL FIRST.
7. ALUMINUM RETAINER SPLICE SHOULD NOT EXCEED 3" [76.2mm] DISTANCE FROM A BRACKET.
8. THE DISTANCE BETWEEN AN ACROVYN SPLICE JOINT AND AN ALUMINUM RETAINER SPLICE JOINT SHOULD BE STAGGERED 2" [50.8mm].
9. TANGENT POINTS ON FACTORY FORMED RADIAL MATERIAL WILL BE MARKED APPROXIMATELY AND SHOULD BE CUT TO SUIT FIELD CONDITIONS.
10. MATERIAL MUST REACH 65°F MIN. TO 75°F MAX. 24 HOURS PRIOR TO INSTALLATION. THIS IS ESSENTIAL TO MINIMIZE EXPANSION AND CONTRACTION OF MATERIAL.
11. MAY REQUIRE USE OF FIRE PUTTY WHEN INSTALLED ON FIRE WALL WITH TOGGLE BOLTS. REFERENCE INSTRUCTIONS 24FIREPUTTY FOR FIRE PUTTY INSTALLATION.
12. THIS HANDRAIL REQUIRES A MINIMUM OF 2 MOUNTING BRACKETS PER UNIT. THE MINIMUM END CAP-TO-END CAP HANDRAIL LENGTH IS 11" [279.4mm].
13. FOR MORE INFORMATION ON HR-6CN HANDRAIL SEE OUR WEBSITE AT [www.c-sgroup.com](http://www.c-sgroup.com).

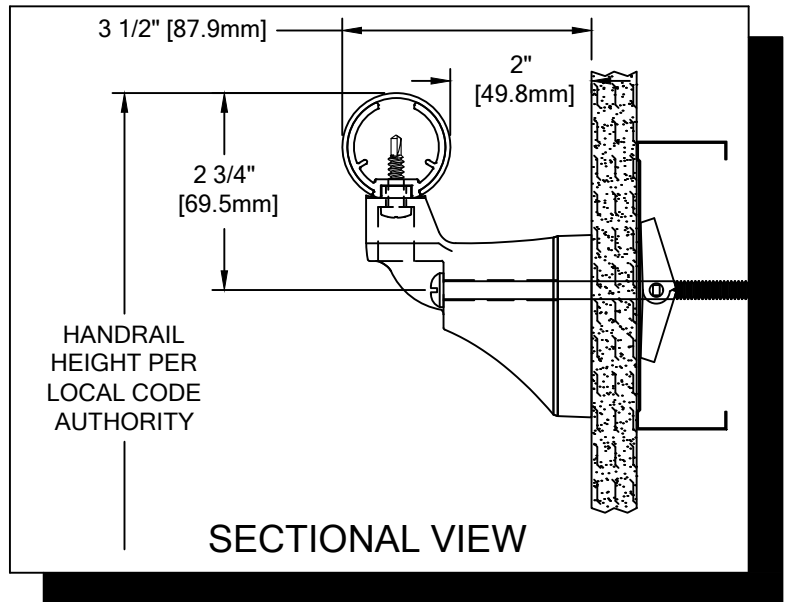

**HR-6CN HANDRAIL  
WITH INTERNATIONAL OFFSET**

COMPONENTS & WALL FASTENERS



ACROVYN HANDRAIL COVER  
(24U032xxx)  
ACROVYN CHAMELEON COVER  
(24U610xxx)



ALUMINUM RETAINER  
(24A095000)



HANDRAIL MOUNTING BRACKET  
(24I127xxx)

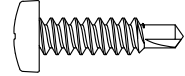

**FASTENER #1**  
#10 X 3/4" S/S PHILLIPS  
PANHEAD TEK SCREW  
(90H739006)

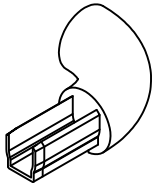

HANDRAIL ENDCAP  
(24I083xxx, RH SHOWN)  
(24I082xxx, LH)  
CHAMELEON END CAP  
(24I634xxx, RH SHOWN)  
(24I610xxx, LH)

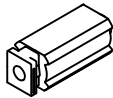

ALIGNMENT PLUG  
(24I051000)

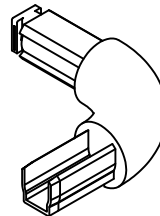

HANDRAIL OUTSIDE  
CORNER ASSEMBLY

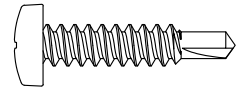

**FASTENER #2**  
#12-14 X 1" S/S PPH  
#3 TEK SCREW  
(90H736006)

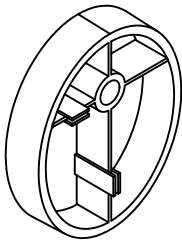

BRACKET EXTENSION  
(24I997xxx)

WALL CONDITION	SPECIFIED FASTENER	DRILL DIAMETERS		CS PART NUMBER
		WALL	RETAINER	
STEEL STUD/GYPSUM WALL	1/4-20 X 5" ROUND HEAD BOLT WITH TOGGLE	3/4"	N/A	90H049002
CONCRETE/CONCRETE BLOCK	#14 X 4" PHILLIPS SS ROUND HEAD AP SCREW	7/32"	N/A	90H225006
WOOD STUD/GYPSUM WALL	#14 X 4" PHILLIPS SS ROUND HEAD AP SCREW	7/32"	N/A	90H225006

**HR-6CN HANDRAIL**  
WITH INTERNATIONAL OFFSET

LAYOUT VIEW

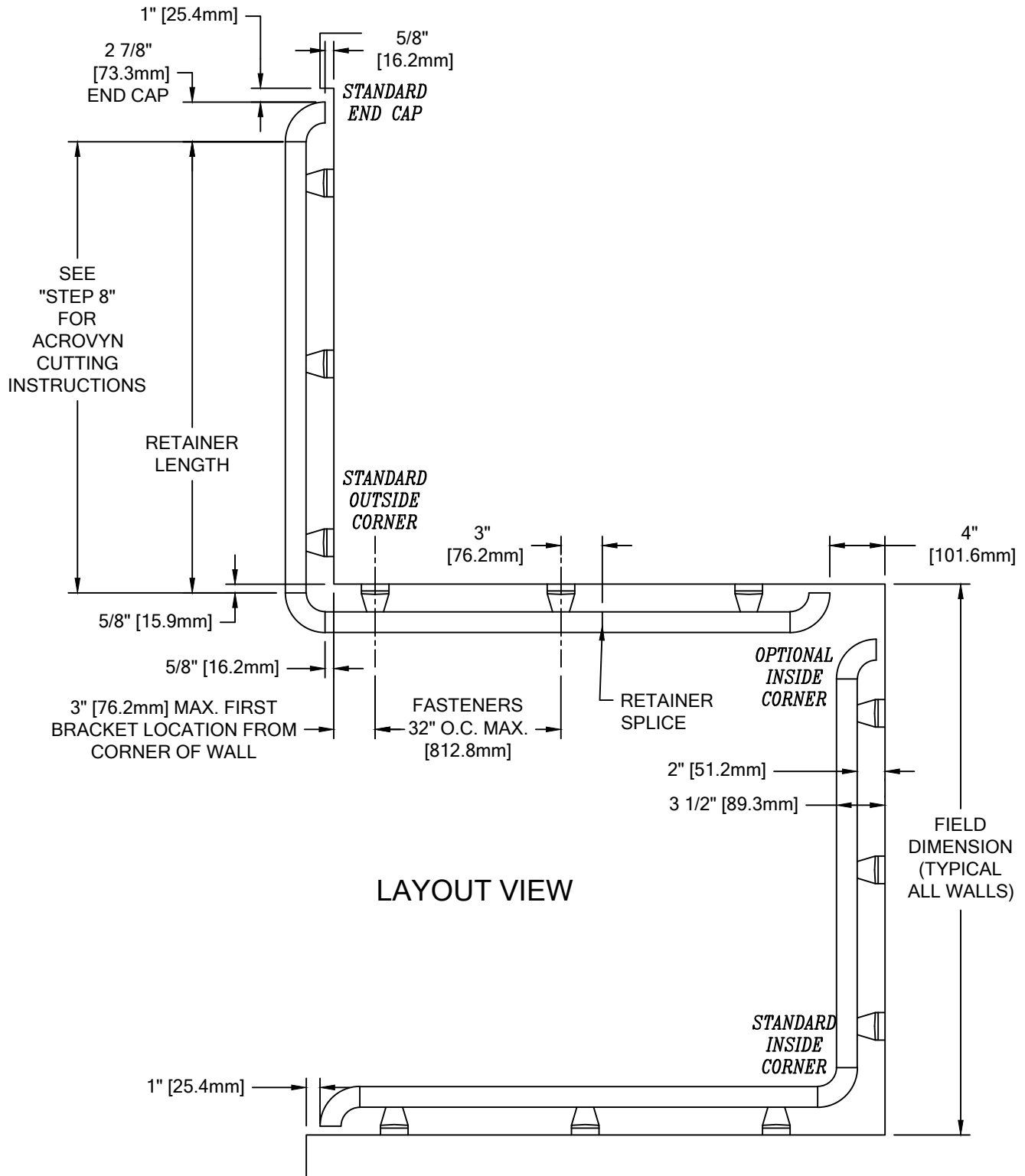

LAYOUT VIEW

**HR-6CN HANDRAIL  
WITH INTERNATIONAL OFFSET**

**TYPICAL ASSEMBLY**

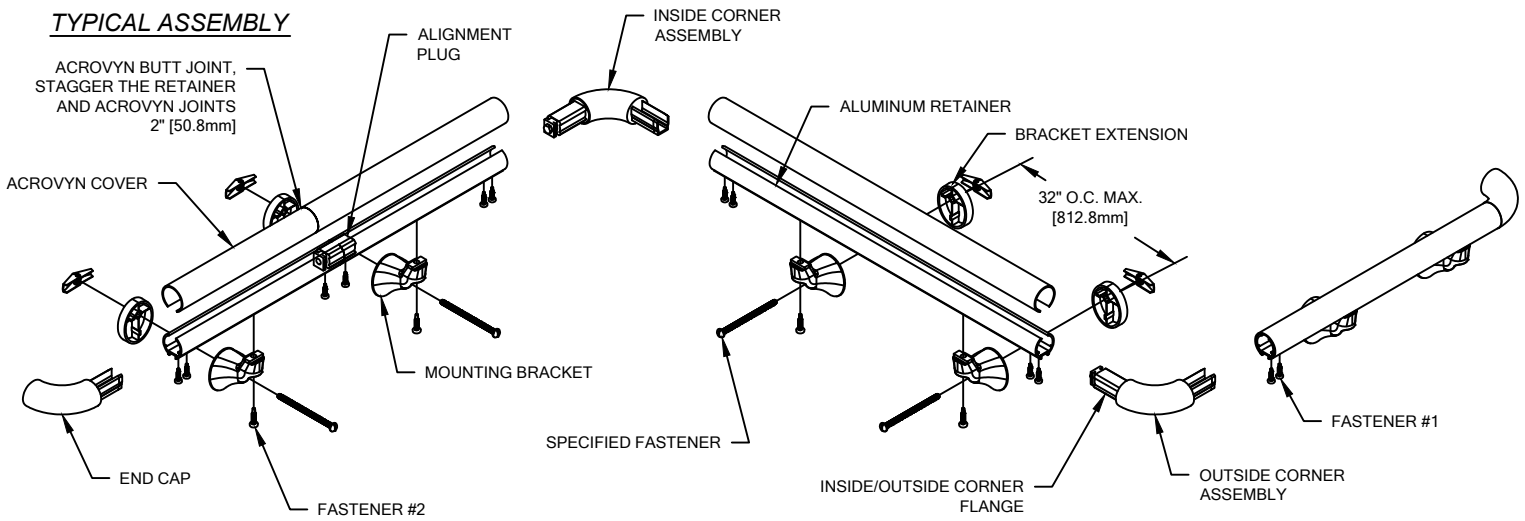

**NOTE:** INSTALLATION OF LINEAL OR RADIAL HR-6CN HANDRAIL SHOULD BE DONE IN ACCORDANCE WITH THE FOLLOWING INSTRUCTIONS.

1. USING "LOCAL CODE" REQUIREMENTS, ESTABLISH HANDRAIL HEIGHT ABOVE FINISH FLOOR. DEDUCT 2-3/4" [69.8mm] AND SNAP A CHALK LINE AT THAT HEIGHT. THIS MARKS THE LOCATION OF THE HOLE FOR THE MOUNTING BRACKET FASTENERS.
2. DRILL CLEARANCE HOLES IN WALL SURFACE FOR MOUNTING HARDWARE. REFERENCE CHART ON PAGE 2 FOR CORRECT DRILL DIAMETERS.
3. INSTALL MOUNTING BRACKETS AND BRACKET EXTENSIONS USING APPROPRIATE FASTENERS. USE A LEVEL TO ENSURE THAT THE BRACKETS ARE LEVEL.

**NOTE:** SEE LAYOUT VIEW TO AID IN MOUNTING BRACKET LOCATION.

4. CUT THE CONTINUOUS ALUMINUM RETAINER TO LENGTH USING THE REQUIRED DEDUCTIONS (SEE LAYOUT VIEW).

**NOTE:** IT IS RECOMMENDED THAT THE ACROVYN COVER AND ALUMINUM RETAINER BE CUT WITH AN 80-100 TOOTH CARBIDE TIPPED SAW BLADE OR EQUIVALENT.

5. ATTACH END CAPS AND INSIDE/OUTSIDE CORNERS:
  - INSERT THE END CAP INTO THE RETAINER.
  - DRILL 1/8" DIAMETER PILOT HOLE THROUGH THE BOTTOM OF THE RETAINER AND END CAP, 7/8" [22.2mm] AND 1-9/16" [39.7mm] FROM THE END OF THE RETAINER.
  - REMOVE END CAP AND DRILL 13/64" CLEARANCE HOLE FOR #10 X 3/4" PHILLIPS PANHEAD TEK SCREW.
  - ATTACH END CAP TO RETAINER WITH THE ABOVE MENTIONED SCREW, UP THROUGH THE BOTTOM OF THE RETAINER.

**NOTE:** TO AID IN LOCATING THE END CAPS CORRECTLY, CUT A 4" [101.6mm] SECTION OF COVER FROM SCRAP AND SNAP IT ON THE RETAINER. LOCATE THE CAP SO IT ALIGNS FLUSH WITH THE TOP AND BOTTOM OF THE COVER.

6. DRILL 1/16" PILOT HOLES INTO THE RETAINER FOR MOUNTING BRACKET ATTACHMENT. MOUNTING BRACKETS ARE TO BE LOCATED 3" [76.2mm] FROM EACH END OF THE RETAINER AND 32" [812.6mm] ON CENTER ALONG LENGTH, AS REQUIRED. FOR OSHPD REQUIREMENTS DRILL 9/32" CLEARANCE HOLE IN RETAINER TO ALLOW THE 1/4-20 X 1-1/4" PHILLIPS ROUND HEAD MACHINE SCREW TO COME DOWN THROUGH THE RETAINER IN TO THE WELL NUT LOCATED IN THE BRACKET.
7. FASTEN THE ALUMINUM RETAINER TO THE WALL BRACKETS IN SUCCESSION BY INSERTING #12-14 X 1" PHILLIPS PANHEAD TEK SCREW THROUGH THE UNDERSIDE OF BRACKET INTO THE RETAINER. **CAUTION:** OVER-TORQUEING MAY CAUSE THE FASTENERS TO STRIP.

**NOTE:** WHEN FIELD FORMING RADIUS HANDRAIL, BE SURE TO APPLY NEEDED PRESSURE FROM BRACKET TO BRACKET.

8. CUT THE ACROVYN COVER TO THE PROPER LENGTH. THE COVER LENGTH IS DETERMINED BY MEASURING THE DISTANCE BETWEEN THE INSTALLED END CAPS AND/OR INSIDE/OUTSIDE CORNER ASSEMBLIES.

**NOTE:** IT IS RECOMMENDED THAT THE ACROVYN COVER BE CUT SLIGHTLY LONGER (1/32" [0.8mm] UP TO 5'0" [1.5m], 1/16" [1.6mm] OVER 5'0" [1.5m]) THAN THE MEASURED DISTANCE. THIS ADDITIONAL LENGTH WILL PROVIDE FOR A TIGHTER COVER-TO-END CAP FIT.

9. STARTING AT ONE END, SNAP THE ACROVYN COVER ONTO THE RETAINER ALONG THE LENGTH OF THE HANDRAIL.

**NOTE:** MANUFACTURER RECOMMENDS ALL PRINTED "PRODUCT IDENTIFICATION" ON THE REAR OF THE ACROVYN PROFILE SHALL BE ORIENTED IN THE SAME DIRECTION DURING INSTALLATION TO ENSURE PROPER ALIGNMENT AT SPLICE BUTT JOINTS.

11/23/16