

MODEL LAS-2G INSTALLATION INSTRUCTIONS

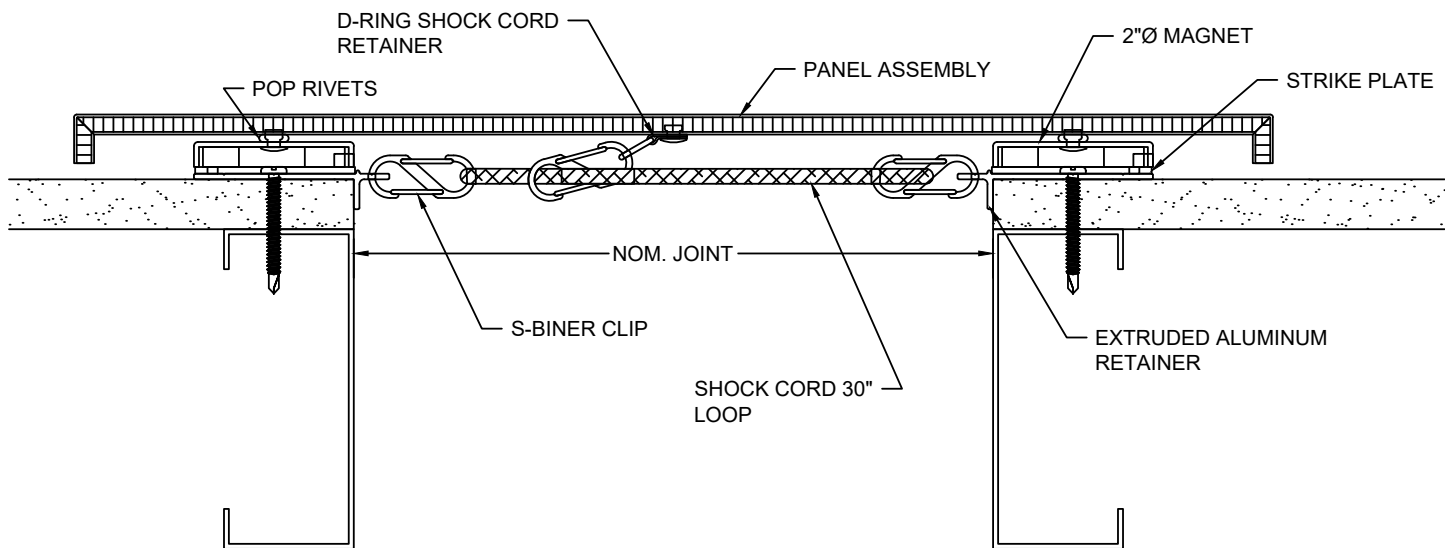

WALL AND CEILING JOINT COVER

IMPORTANT INFORMATION

Prior to the commencement of installation all materials **MUST** be inspected for damage. Any damage must be reported to **CONSTRUCTION SPECIALTIES, INC.**, as soon as possible, so that replacement materials may be furnished without delay.

All work must be completed as per Architect's Approved "Shop Drawings", and in accordance with these Installation Instructions. When installation is complete, all materials must be protected from damage until the Architect's **FINAL INSPECTION**.

All materials should be arranged in the order that they are to be installed. All hardware required for each portion of the work should be placed with the appropriate materials.

Please review all Approved Shop Drawings and this document to familiarize yourself with all the details and components of this assembly.

IMPORTANT:

READ THROUGH ALL INSTRUCTIONS PRIOR TO STARTING INSTALLATION

3/4/2021



Construction Specialties™

6696 Route 405 Highway, Muncy PA 17756
(800) 233-8493 • Fax (570) 546-5169 • www.c-sgroup.com

This document is the property of Construction Specialties, Inc. and contains **CONFIDENTIAL PROPRIETARY INFORMATION** that is not to be disclosed to third parties and is not to be used without approval in writing from Construction Specialties, Inc.

GENERAL NOTES

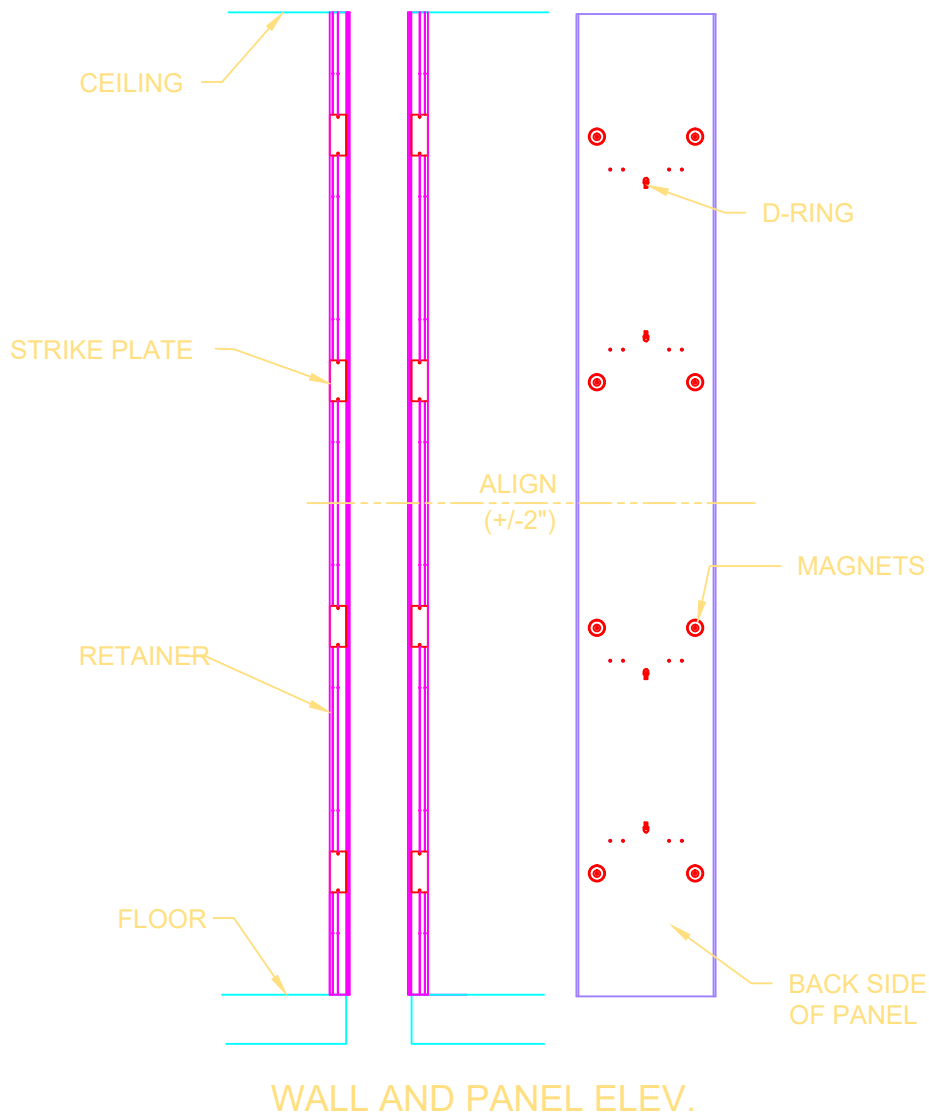

WALL AND PANEL ELEV.

IMPORTANT NOTE:

For proper installation of the LAS-2G covers it is necessary to always maintain the alignment of the magnets on the back of the Cover Panels with the Strike Plates on the Retainers. Always coordinate the cutting of the Panels with the cutting of the Retainers so that the alignment is maintained.

1. LAS-2G joint covers are to be installed flush with the face of the wall or ceiling and are to be centered over the joint. Face of Wall or ceiling where LAS-2G joint covers are being installed should be level $\pm 3/16"$.
2. Before beginning installation of the LAS-2G joint covers, review the architectural drawings and approved CS shop drawings to familiarize yourself with the locations of the LAS-2G and other joint cover systems.
3. Coordinate the installation of the LAS-2G wall and/or ceiling joint covers with installation of fire barrier systems, floor joint covers and other wall and ceiling joint covers.
4. Always carry the Panels on edge to minimize bowing of the Panels.
5. The primed surface on the Cover Panels is intended to be field painted to match adjacent wall and/or ceiling finish paint. We recommend using Cardinal 3600 Series Paint per manufacturer's guidelines, it was tested in accordance to ASTM-3359. If alternative paint is desired, test a small section of the panel per manufacturer's guidelines prior to painting the entire panel to determine if paint will adhere properly to primer. We do not guarantee that alternative paints will adhere.
6. The LAS-2G Cover Panels may be cut, when required, using a straight edge and a circular saw, table saw or radial arm saw.
7. When LAS-2G covers are being installed at both wall and adjacent ceiling locations, ceiling covers are to be installed first.

STEP 1

INSTALL RETAINERS

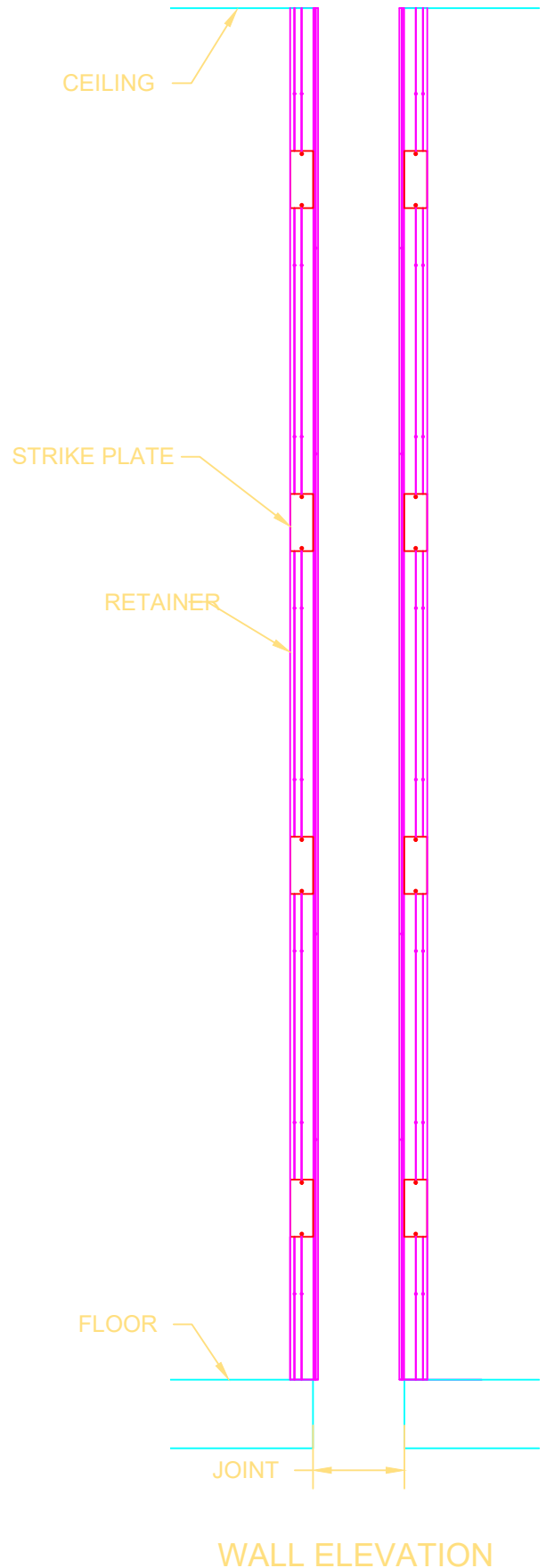
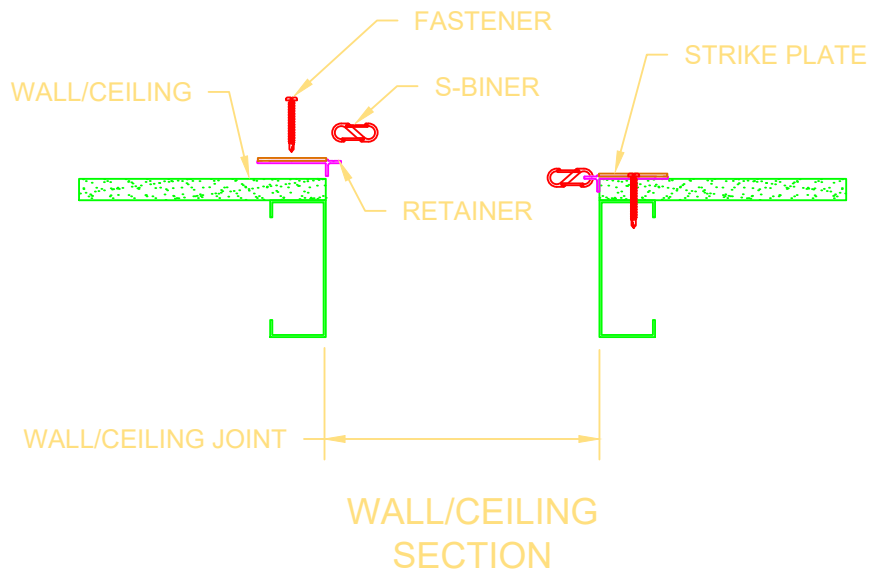

STEP 1:

Note: The Aluminum Retainers are to run from the floor to ceiling at wall joint application. The Retainers are supplied in 120" lengths. If the ceiling height or ceiling run length exceeds 120", two or more lengths of Retainers are to be installed for the required length. If LAS-2G covers are being installed at both wall and ceiling, the wall Retainer should butt against the ceiling Retainer.

- 1.1) Select a pair of the 120" Retainers and if needed, cut to length. See the Panel/Retainer Cutting Information at the end of these instructions. **Note:** Position the Retainer in the proper left-hand or right-hand orientation before cutting in order to maintain alignment of the Magnets. Miter cut the appropriate end if needed.
- 1.2) Position each Retainer tightly to the corner of the wall/ceiling at the joint edge and anchor to the wall/ceiling with the appropriate CS supplied fastener. **Note:** If multiple lengths of Retainer are required, install 120" lengths first. Anchor holes are to be a maximum of 6" from each end. If these end holes were cut off when cutting the Retainer to length, drill new holes 3" to 6" in from the end.

STEP 2

INSTALL RETAINER ACCESSORIES

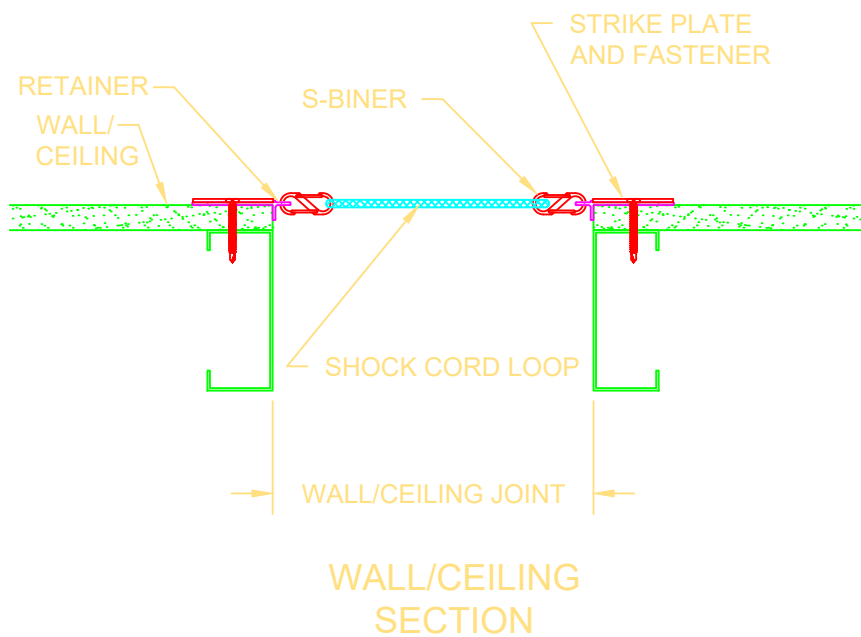

STEP 2:

Note: Model sizes larger than 2400 require additional S-Biners.

- 2.1) Place S-Biners into the appropriate holes in the Retainers by inserting them from the backside coming forward. **Note:** The S-Biners are to be 32"-36" apart along the Retainer
- 2.2) Place a Shock Cord onto S-Biners by clipping in the Loop in the top two S-Biners and stretching the Loop down to engage the other two S-Biners. **Note:** Locate the knot of the Shock Cord Loop near the center of one of the vertical lengths of the Loop.
- 2.3) Repeat on opposite end of the Retainer with second Shock Cord (if S-Biner and Shock Cord Configurations call for a second Shock Cord).

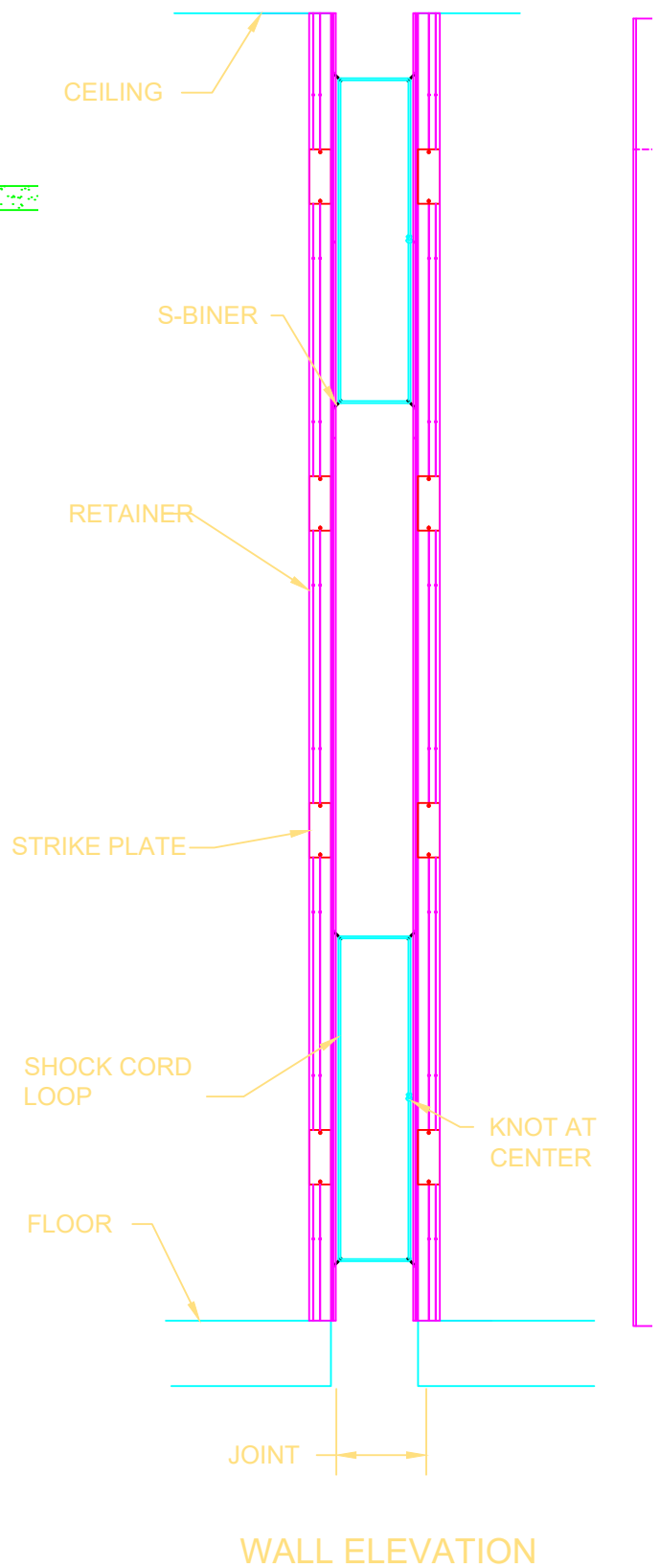

STEP 3

PREPARE COVER PANELS FOR INSTALLATION

WALL/CEILING CORNER SECTION

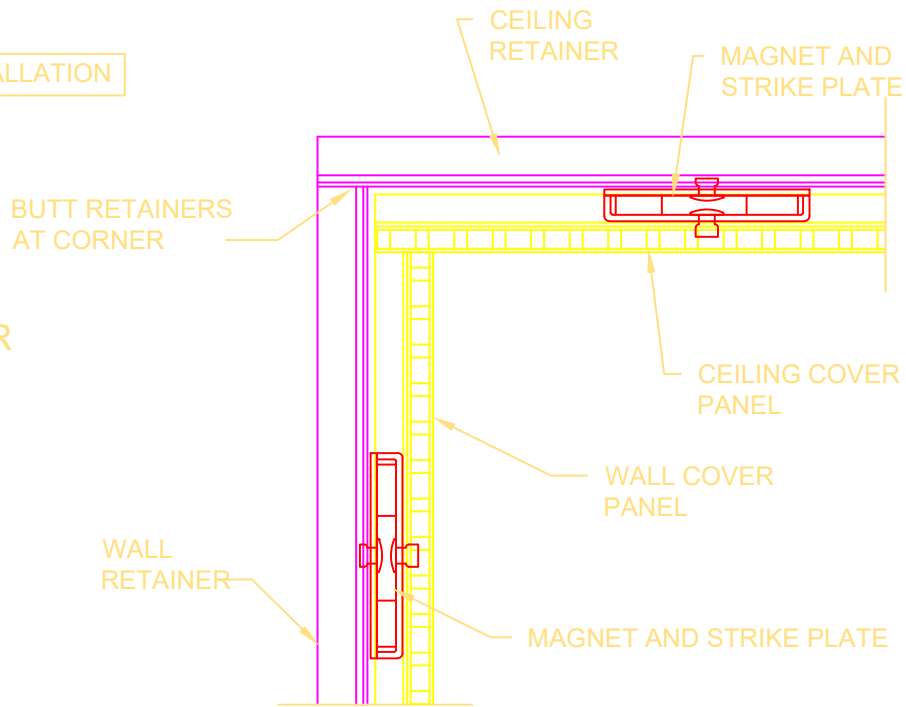

STEP 3:

Note: Before cutting (if required) and installing the Cover Panels consider the following:

- If model LAS-2G covers are being used at both wall and ceiling (inside corner), ceiling joint Cover Panels are to be installed prior to wall Panels and the wall Cover Panels will finish to the face of the ceiling Cover Panel.
- If more than one Cover Panel is required for a run, install the longest Panel(s) first.
- All Cover Panels are supplied in 120" lengths.
- Field verify ceiling height dimensions and ceiling run length dimensions before cutting Panels.
- When cutting Cover Panels to a required length, coordinate the Panel cutting with the cuts made to the Retainers in order to maintain alignment of the Magnets and Strike Plates.
- Support the Panels to prevent excessive bowing which may damage the Panel.
- The LAS-2G Cover Panels may be cut, when required, using a straight edge and a circular saw, table saw or radial arm saw.

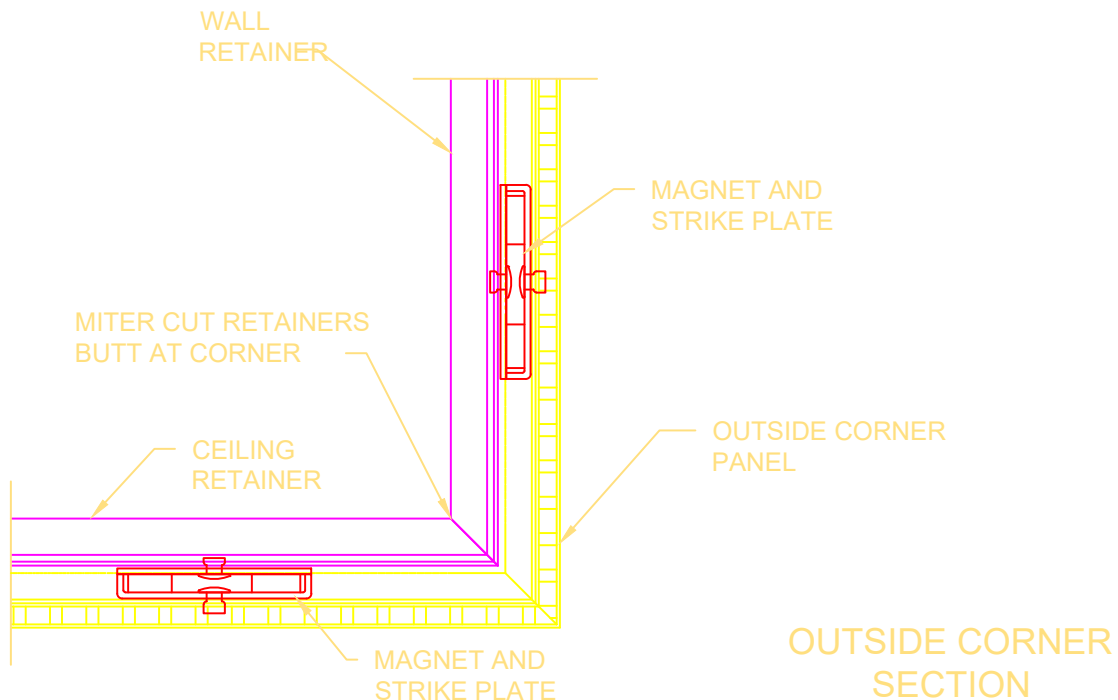

STEP 4

PANEL INSTALLATION

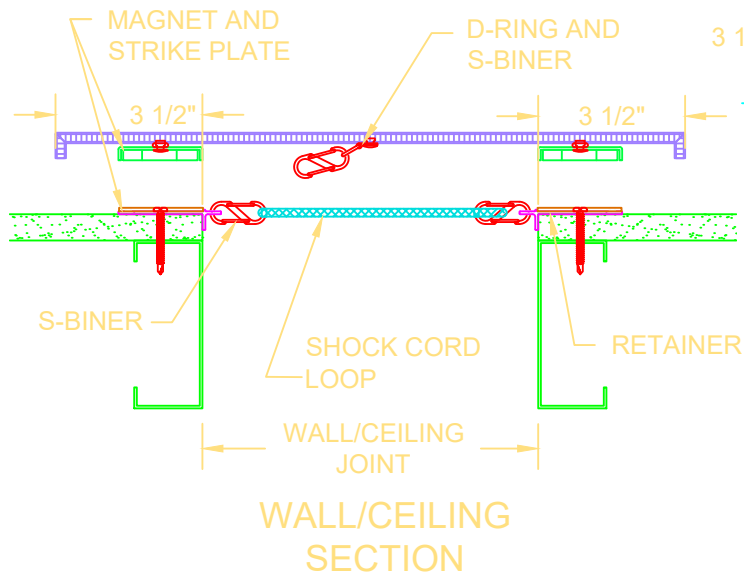

STEP 4:

Note: See the Panel / Retainer Cutting Information at the end of these instructions for details.

- 4.1) With the Cover Panel now cut to the appropriate length, place the Panel along side the Retainers to confirm that the Magnets and Strike Plates are in alignment.
- 4.2) At one or both sides of the joint, place light pencil marks on the face of the wall or ceiling at 3-1/2" (see details for locations). Note: These marks will be used to properly center the Cover Panel over the joint. The marks must be plumb and parallel to the joint.
- 4.3) Position the Cover Panel over the joint with the backside of the Panel towards the wall / ceiling and Retainers.,
- 4.4) Angle one edge of the Panel to allow access to the backside of the Panel and the Shock Cord loops.
- 4.5) Capture the Shock Cord with D-Ring and S-Biner on the backside of the Panel to the Shock Cord loops. Each Shock Cord loop should be engaged with one of the D-Ring with S-Biners.
- 4.6) With Cover Panel centered over the joint push the panel back to engage Magnets with Strike Plates on the Retainers.

Panel Finishing

Note: The LAS-2G Cover Panels are to be field painted, the painting should be done at this stage. Follow the finishing steps below:

- **Remove the protective plastic covering from Panel.**
- CS recommends testing a small section of the panel prior to painting entire panel to test the paint's adhesion to the primer.
- Apply interior paint to the epoxy primer.
- Apply additional coats of the interior paint as required.

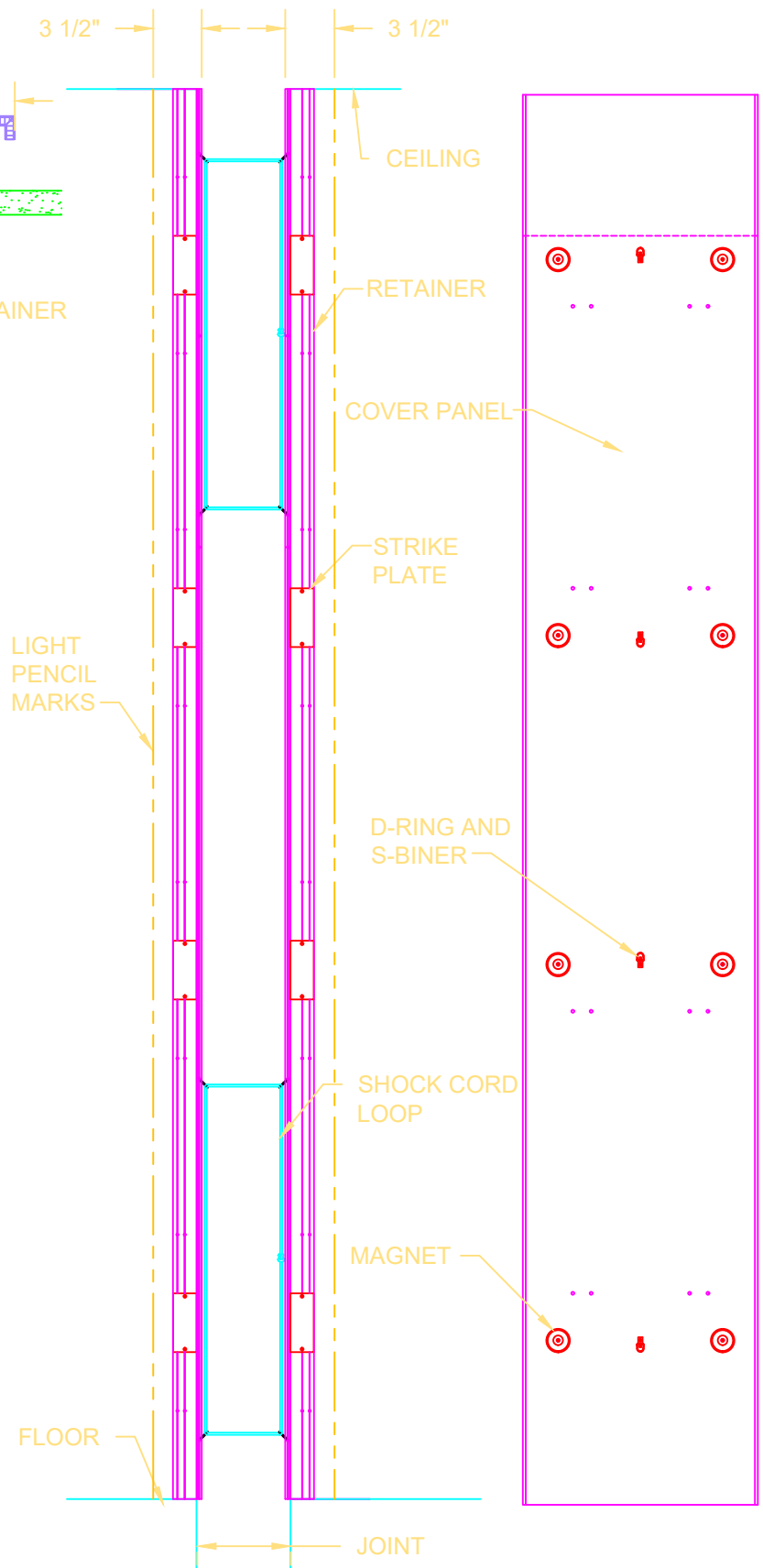

WALL ELEVATION

ALIGNMENT BAR INSTALLATION

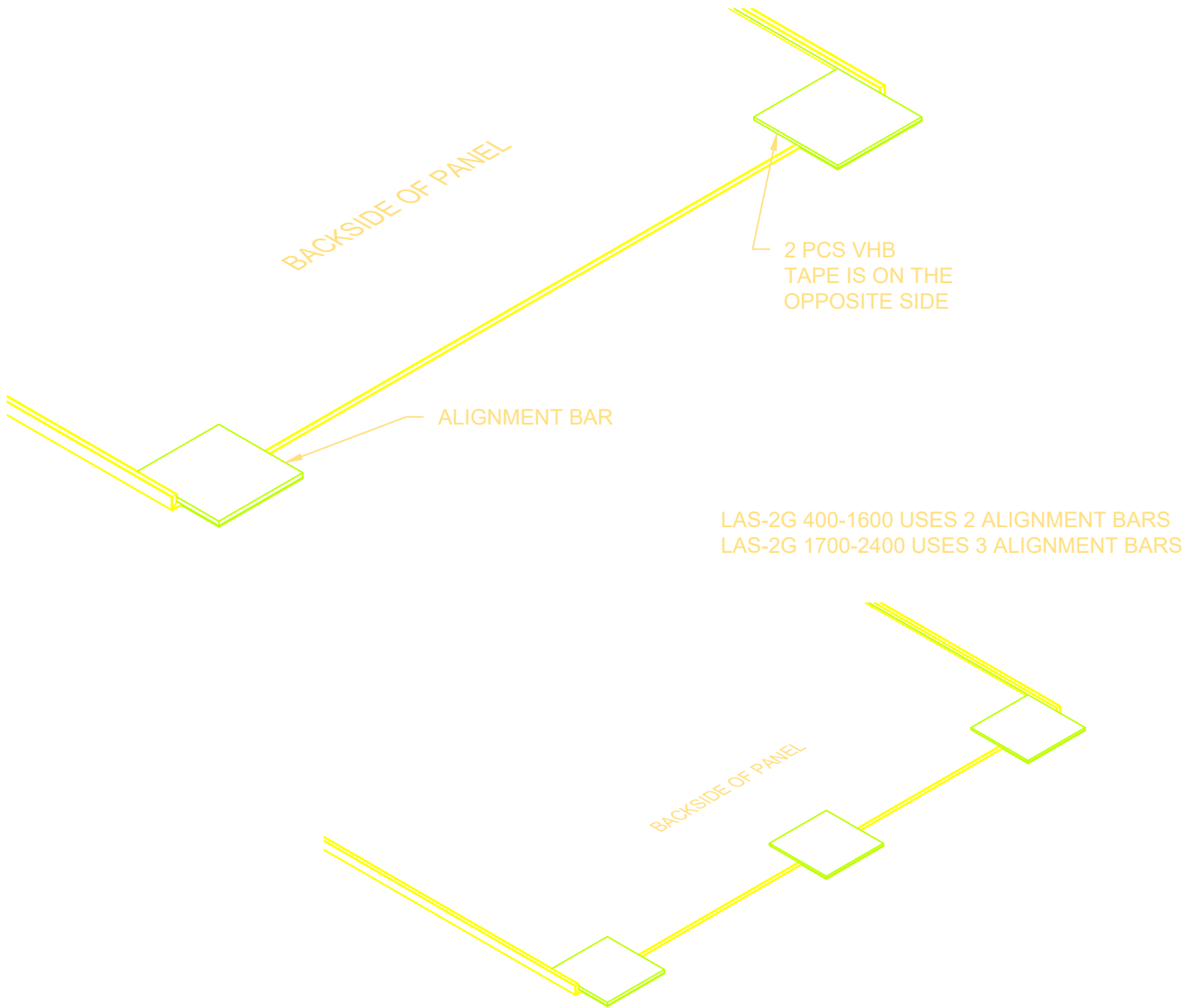

1. For run lengths exceeding 120", combine 120" section with the appropriate cut section. Use Alignment Bars to line up the sections of panel. Larger width panels require more than two Alignment Bars (as detailed). Minimum Panel and Retainer length is $30\frac{3}{4}$ ".
2. To attach the Alignment Bars to the backside of the panel, remove the protective strip on one piece of VHB Tape. Apply the exposed piece of VHB Tape of the Alignment Bar to the installed panel. (See details above)
3. When ready to connect panels remove the other protective strip of the VHB Tape on the Alignment Bar to expose the adhesive.
4. Align next length of panel while maintaining the previous steps for panel installation and slide together. Press on the previously installed panel at the locations of the alignment bars in order to contact adhesive.

400-2400 CUT DOWN PANEL LENGTHS

