

MODEL SGP/SGR-500 THRU 1600 & SGPW/SGRW-500 THRU 1600 INSTALLATION INSTRUCTIONS

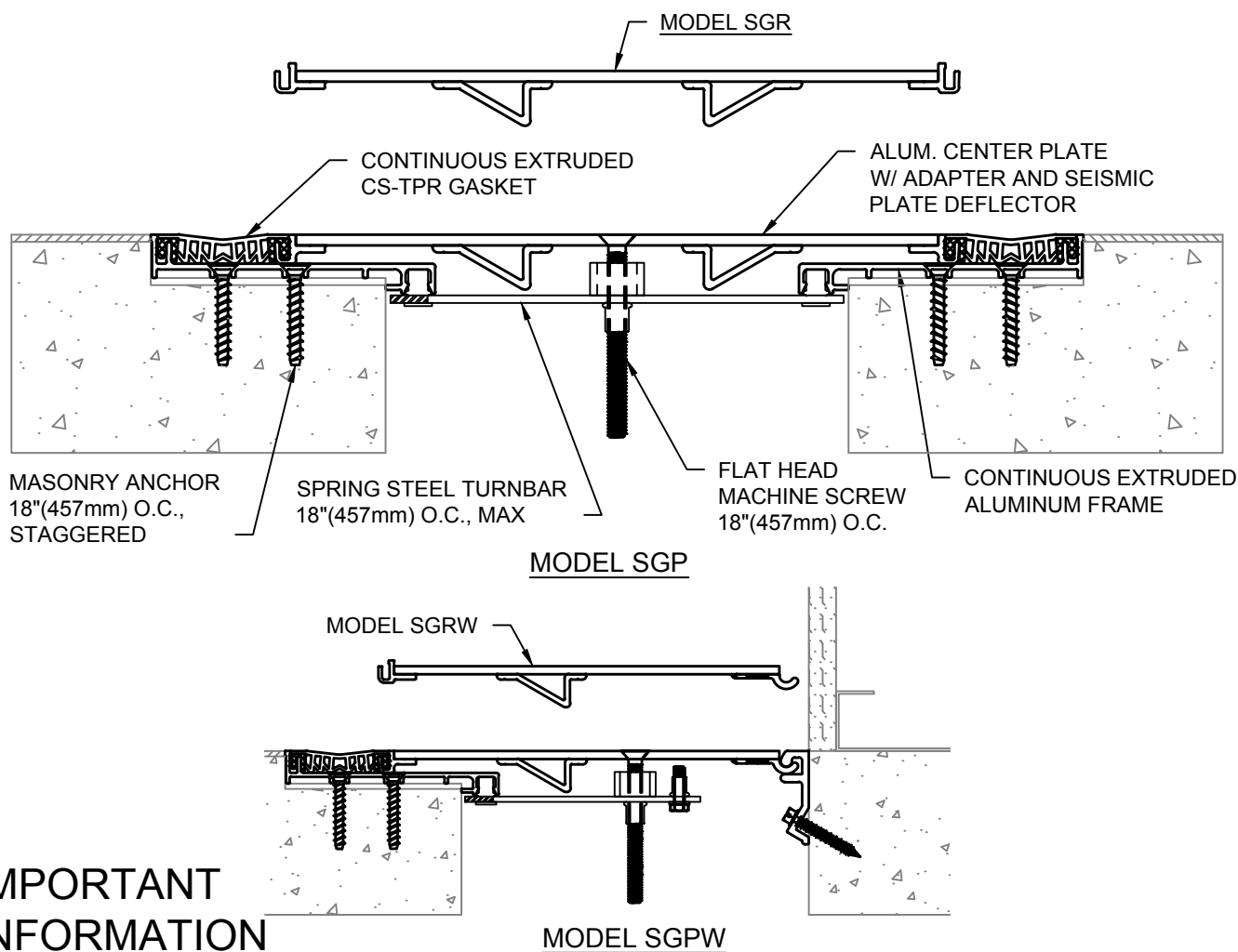

IMPORTANT INFORMATION

Prior to the commencement of Installation, all materials MUST be inspected for Damage. Any damage must be reported to CONSTRUCTION SPECIALTIES, INC., as soon as possible, so that replacement materials may be furnished without delay.

All work must be completed as per Architect's Approved "Shop Drawings", and in accordance with these Installation Instructions. When installation is complete, all materials must be protected from damage until the Architect's FINAL INSPECTION.

All materials should be arranged in the order that they are to be installed. All hardware required for each portion of the work should be placed with the appropriate materials.

Please review all Approved Shop Drawings and this Document to familiarize yourself with all the details and components of this assembly.

IMPORTANT:

READ THROUGH ALL INSTRUCTIONS PRIOR TO STARTING INSTALLATION

3/31/17



Construction Specialties™

6696 Route 405 Highway, Muncy PA 17756
(800) 233-8493 • Fax (570) 546-5169 • www.CSgroup.com

This document is the property of Construction Specialties, Inc. and contains CONFIDENTIAL PROPRIETARY INFORMATION that is not to be disclosed to third parties and is not to be used without approval in writing from Construction Specialties, Inc.

Notes:

Before beginning installation, review the architectural drawings and approved Construction Specialties Inc. shop drawings to familiarize yourself with the joint cover models and locations.

Check all of the joint cover components to confirm that the correct joint cover model and size have been received. Also, check for materials that may have been damaged during shipping. Report all incorrect and/or damaged components to CS at 800-233-8493.

Read through all the steps of these instructions prior to beginning work.

STEP 1

PREPARE BLOCKOUT

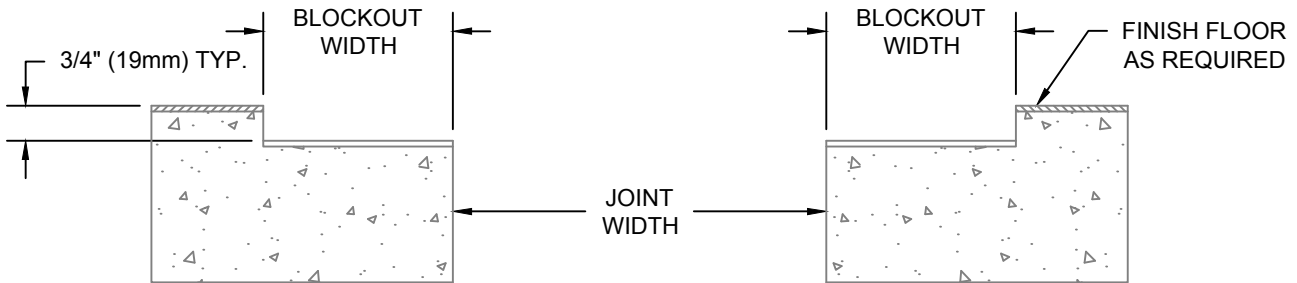

Step 1:

- 1.1) The blockouts must be prepared to receive the joint cover.
 - The blockout width will vary with model as indicated on the CS shop drawings.
 - The blockout depth will typically be 3/4" (19mm). However, the depth may be adjusted as needed to accommodate a floor finish material when required and as indicated on the architectural drawings and/or CS shop drawings.
 - It is recommended that the blockout be formed a minimum of 1/8" deeper to allow the blockouts to be leveled for installation of the joint cover.
 - Apply a self leveling grout to the base of the blockouts to provide a continuous, solid, flat and level base for the joint cover. (Note: The blockouts must be level across the width of the joint.)

STEP 2

SPACER INSTALLATION

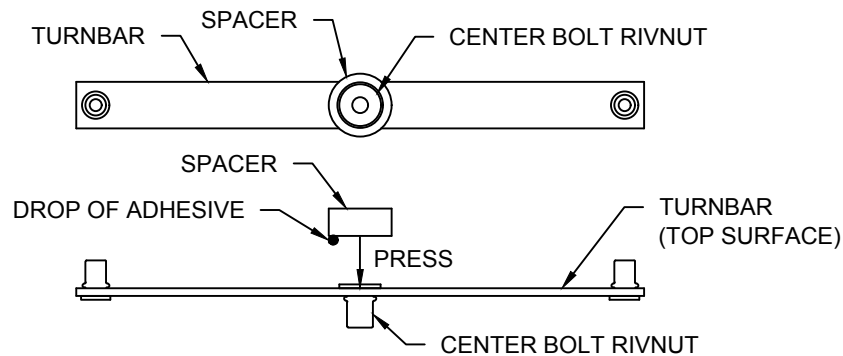

Step 2:

Notes: A Spacer must be placed between the Turnbar and the underside (or backside) of the Cover Plate. The Spacer is used to prevent excess bowing of the Turnbars when the center bolt is tightened. (Some bowing of the Turnbars is required to apply the holding force on the Cover Plate.)

- 2.1) Place a small drop of "super glue" adhesive (not supplied) onto one end of a Spacer.
- 2.2) Position the end of the Spacer with the adhesive against the top surface of the Turnbar, centered over the flat head portion of the Center Bolt Rivnut (see detail above).
- 2.3) Press firmly for a few seconds until the Spacer is bonded to the Turnbar.
- 2.4) Install the Turnbars as instructed.

STEP 3

FRAME INSTALLATION

MASONRY ANCHOR
18"(457mm) O.C.,
STAGGERED

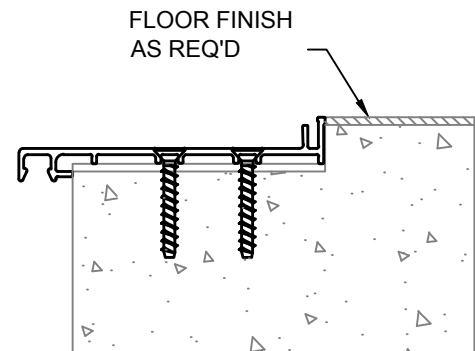
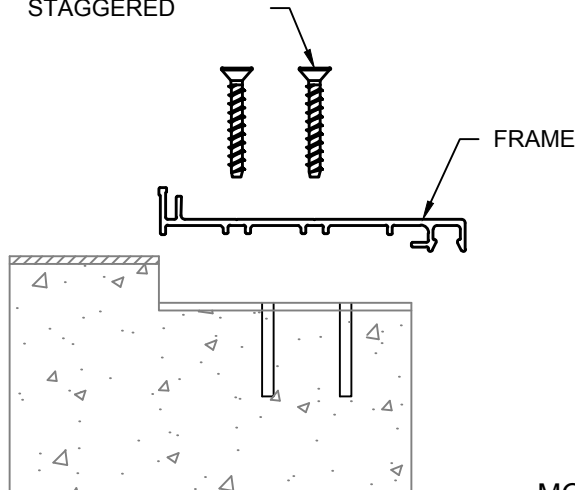

MODELS SGP/SGR

Notes: If a CS Fire Barrier is to be installed in the joint, please review the Fire Barrier Installation Instructions supplied, and if required install the Fire Barrier BEFORE installation of CS Seismic Expansion Joint Aluminum Frames.

If a Waterstop is to be installed in the joint, please review the Waterstop Installation Instructions supplied, and if required install the Waterstop BEFORE installation of CS Seismic Expansion Joint Aluminum Frames.

Step 3:

- 3.1) Begin installation of the Frames by placing a length of Frame into the breakout. Cut the Frame to length as needed. The Frame is to sit level, flat and parallel to the edge of the joint.

Note: The Frame is to overhang the edge of the joint (see detail above).

- 3.2) Using the Frame as a template, mark the locations of the CS supplied anchor bolts.
- 3.3) Remove the Frame and drill the holes for the CS supplied anchor bolts. The holes are to be drilled with the appropriate size and type of drill bit as indicated by the manufacturer of the CS supplied anchor bolts.
- 3.4) Reposition and anchor the Frame to the slab using the CS supplied anchor bolts per approved shop drawings and in accordance with the manufacturer's guidelines.
- 3.5) Repeat this installation procedure for the opposite side of the joint and for any additional lengths of Frame.

STEP 4

WALL FRAME INSTALLATION

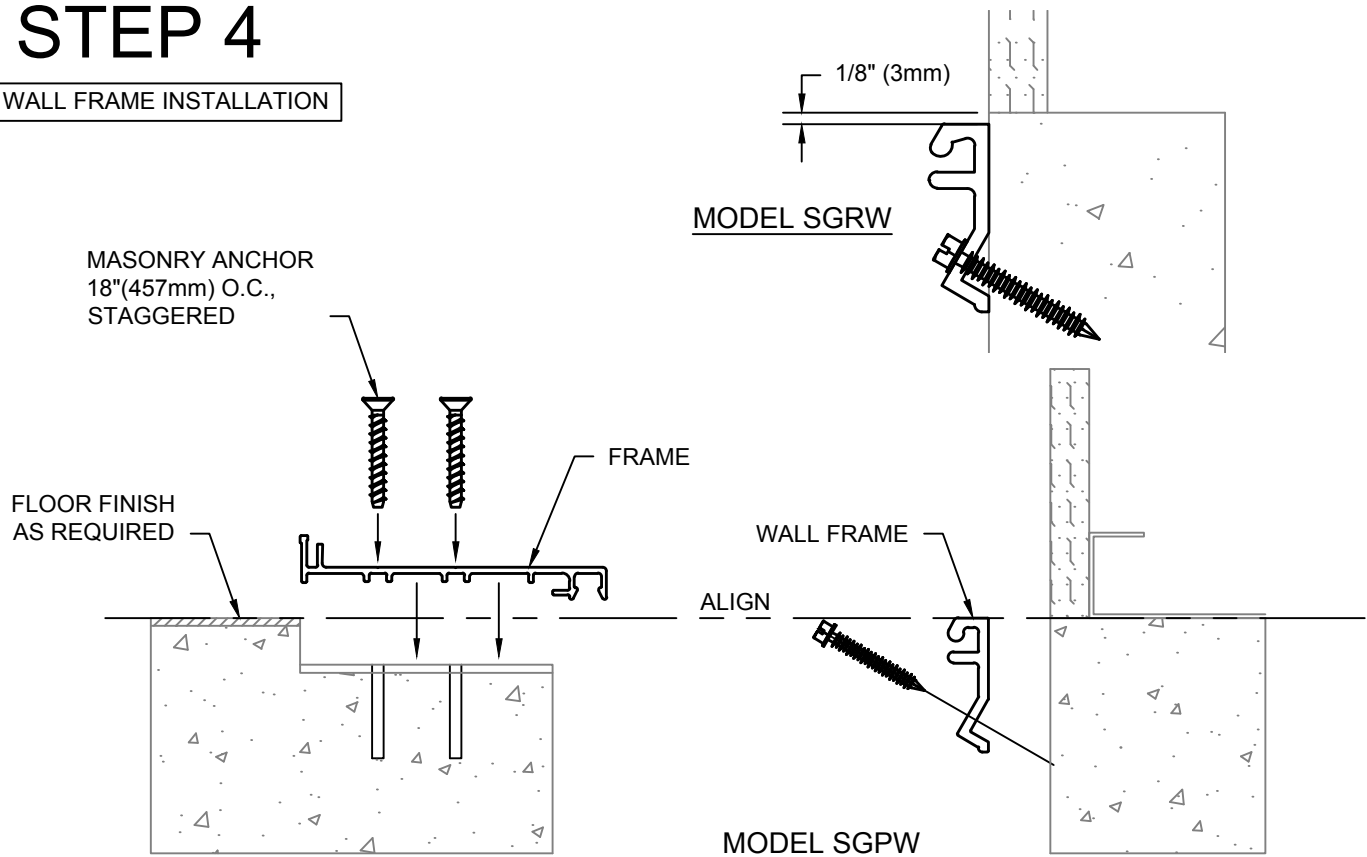

Notes: If a CS Fire Barrier is to be installed in the joint, please review the Fire Barrier Installation Instructions supplied, and if required install the Fire Barrier BEFORE installation of CS Seismic Expansion Joint Aluminum Frames.

If a Waterstop is to be installed in the joint, please review the Waterstop Installation Instructions supplied, and if required install the Waterstop BEFORE installation of CS Seismic Expansion Joint Aluminum Frames.

For Model SGRW the top of the Wall Frame is located 1/8" down from top of floor slab (see detail above).

Step 4:

- 4.1) Begin installation of the Frame by placing a length of Frame into the blockout. Cut the Frame to length as needed. The Frame is to sit level, flat and parallel to the edge of the joint.

Note: The Frame is to overhang the edge of the joint (see detail above).

- 4.2) Using the Frame as a template, mark the locations of the Frame anchor bolts.
- 4.3) Remove the Frame and drill the holes for the anchor bolts. The holes are to be drilled with the appropriate size and type of drill bit as indicated by the manufacturer of the CS supplied anchor bolts.
- 4.4) Reposition and anchor the Frame to the slab using the CS supplied anchor bolts per approved shop drawings and in accordance with the manufacturer's guidelines.
- 4.5) Repeat this installation procedure for any additional lengths of Frame.
- 4.6) Align the top of the Wall Frame with the top of the slab. (For Model SGRW place top of Wall Frame 1/8" down from slab.)
- 4.7) Using the Wall Frame as a template, mark the locations of the Wall Frame anchor bolts.
- 4.8) Remove the Wall Frame and drill the holes for the CS supplied anchor bolts. The holes are to be drilled with the appropriate size and type of drill bit as indicated by the manufacturer of the CS supplied anchor bolts.
- 4.9) Reposition and anchor the Wall Frame to the slab using the CS supplied anchor bolts per approved shop drawings and in accordance with the manufacturer's guidelines.
- 4.10) Repeat this installation procedure of the Wall Frame for any additional lengths of Wall Frame.

***Note: Before beginning the Turnbar installation, review the two different installation methods provided Wedge Block and Tape Installations.

STEP 5

TURNBAR INSTALLATION

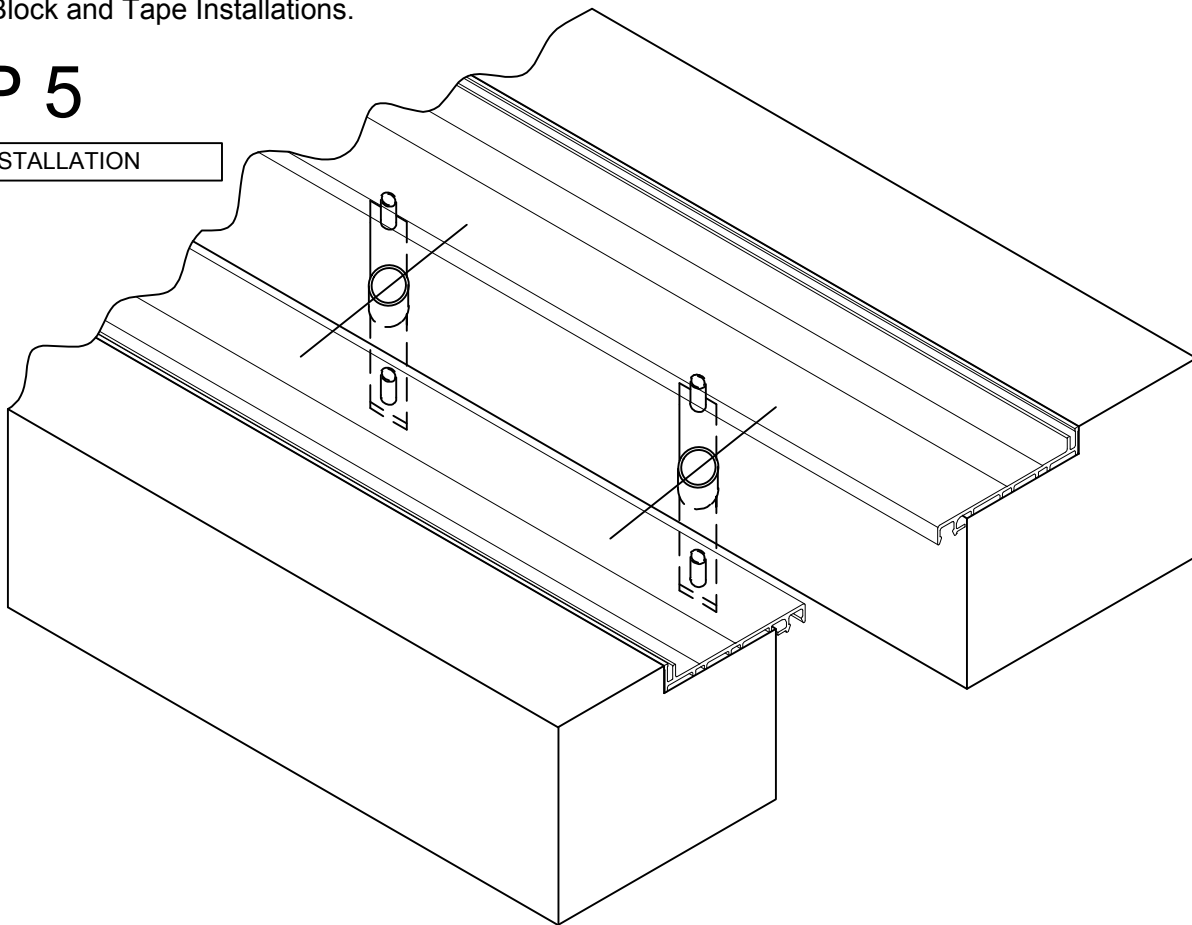

MARKED TURNBAR CENTER LINE LOCATIONS ON FRAMES

ANCHOR FRAME

ANCHOR FRAME

18"
(Max.)

Distance to first hole in Centerplate

18"
(Max.)

STEP 5 (Flr. to Flr. Wedge Block Method)

WEDGE BLOCK TURNBAR/CENTER PLATE INSTALLATION

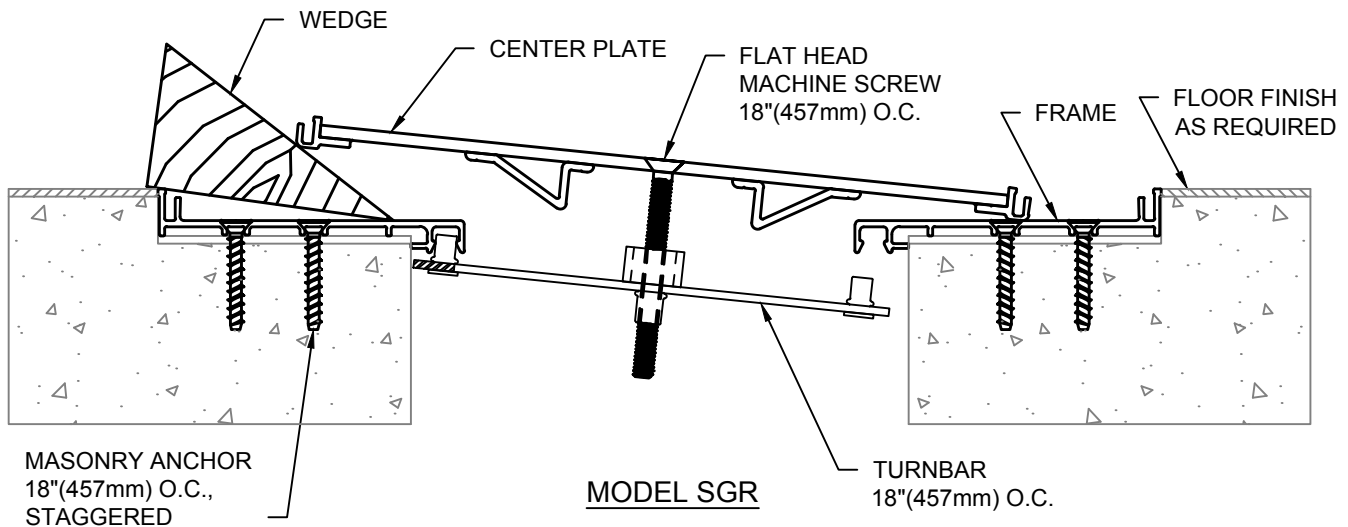
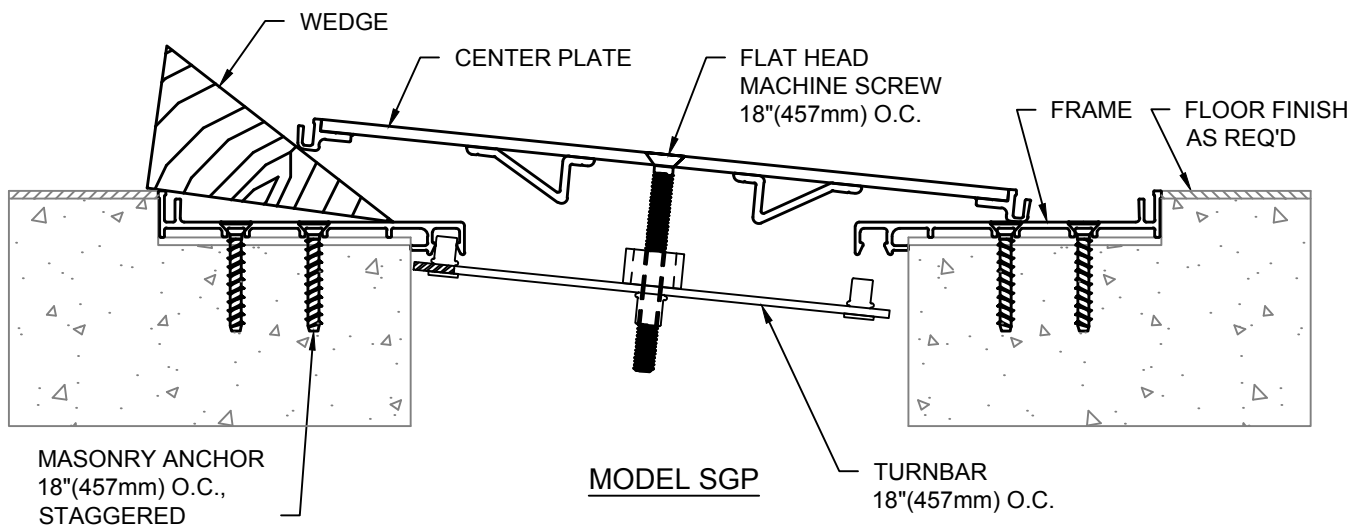

Step 5:

- 5.1) Prepare the Center Plate for installation by first cutting the Plate to length as needed.
- 5.2) Attach a Turnbar to the backside of the Center Plate at each hole location. (Note the orientation of the Turnbar in the detail on page 5.) Thread a machine screw only approx. 1/4" into the Turnbar for now.
- 5.3) Place the Center Plate/Turnbar Assembly against one side of the Seismic Expansion Joint at an angle that will allow hand penetration behind the Center Plate. With the Center Plate in this position, reach behind the Center Plate and locate the pivot pin of the end Turnbar into the pivot pin receivers of the Frame on each side of the joint.
- 5.4) Slide a wedge block beneath the Center Plate to hold the Turnbar securely into position.
- 5.5) Repeat this procedure with the Turnbar at the opposite end of the Center Plate.
- 5.6) Locate each of the remaining Turnbars into position, then progressively tighten all machine screws and remove the wedge blocks until the Center Plate is securely fastened onto the Frame system. (**Note: The Turnbars must be angled the same direction to allow for movement.**)
- 5.7) Repeat this procedure for any additional lengths of center plate.

STEP 5 (Flr. to Wall Wedge Block Method)

WEDGE BLOCK TURNBAR/CENTER PLATE INSTALLATION

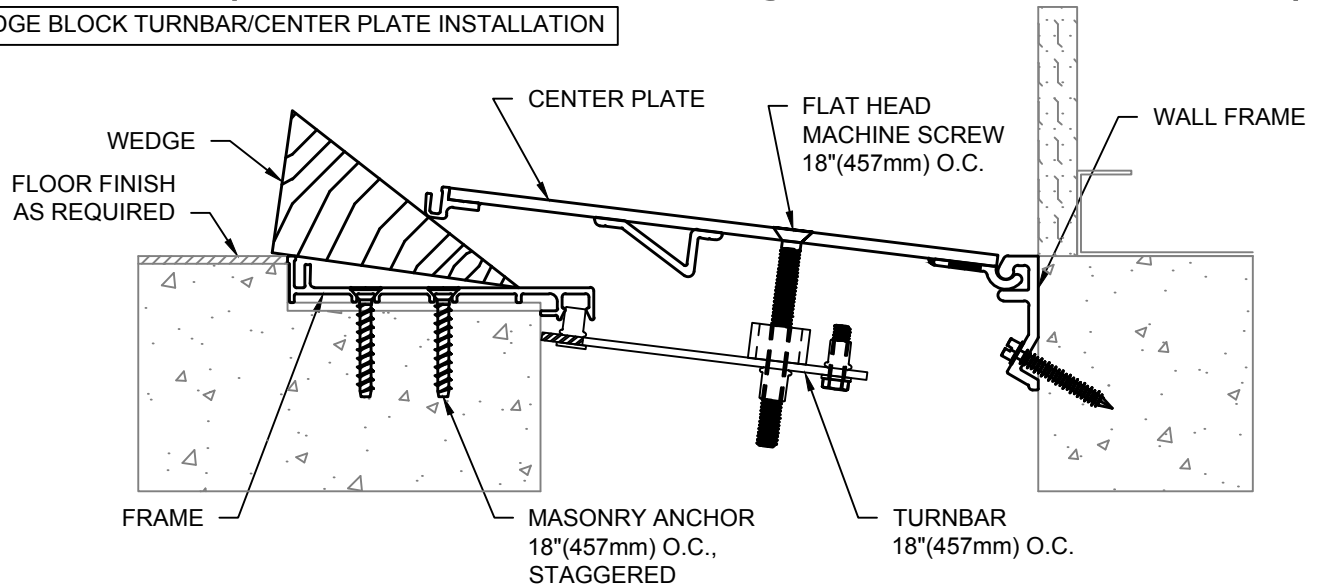

MODEL SGPW

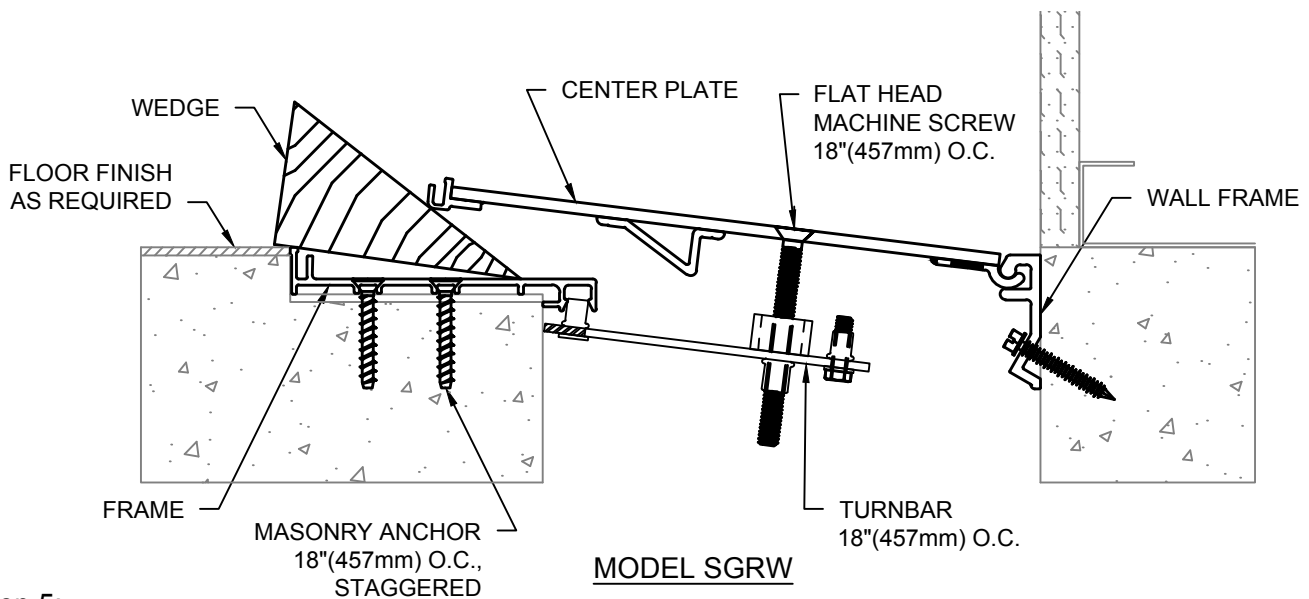

MODEL SGRW

Step 5:

- 5.1) Prepare the Center Plate for installation by first cutting the Plate to length as needed.
- 5.2) Attach a Turnbar to the backside of the Center Plate at each hole location. (Note the orientation of the Turnbar in the detail on page 5.) Thread a machine screw only approx. 1/4" into the Turnbar for now.
- 5.3) Place the Center Plate's hook into the hinge of the Wall Frame and rotate the Center Plate at an angle that will allow hand penetration behind the Center Plate. With the Center Plate in this position, reach behind the Center Plate and locate the pivot pin of the end Turnbar into the pivot pin receivers of the Frame on each side of the joint.
- 5.4) Slide a wedge block beneath the Center Plate to hold the Turnbar securely into position.
- 5.5) Repeat this procedure with the Turnbar at the opposite end of the Center Plate.
- 5.6) Locate each of the remaining Turnbars into position, then progressively tighten all machine screws until the Center Plate is securely fastened onto the Frame system. (**Note: The Turnbars must be angled the same direction to allow for movement.**)
- 5.7) Repeat this procedure for any additional lengths of Center Plate.

STEP 5 (Flr. to Flr. Tape Method)

TAPE TURNBAR/CENTER PLATE INSTALLATION

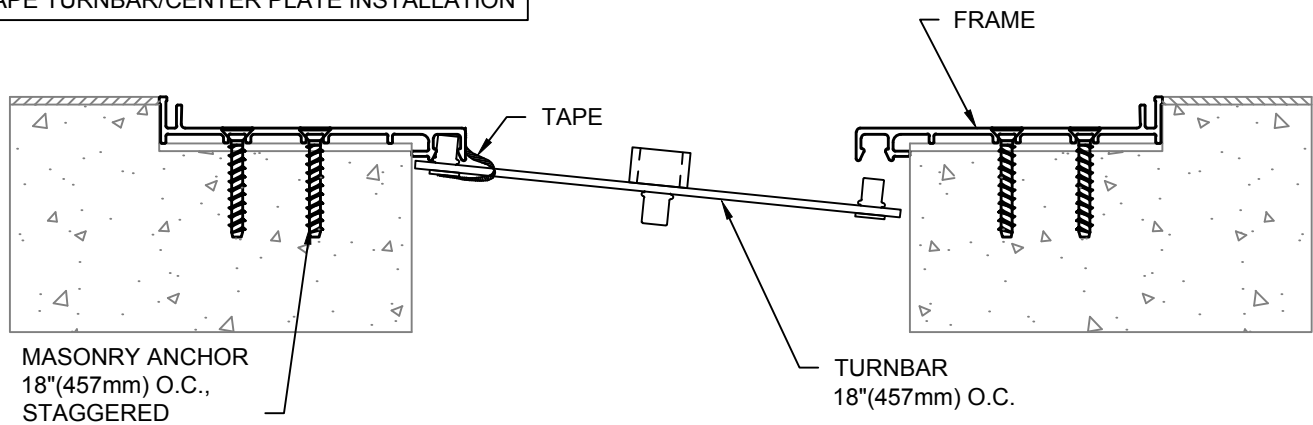

MODEL SGP/SGR

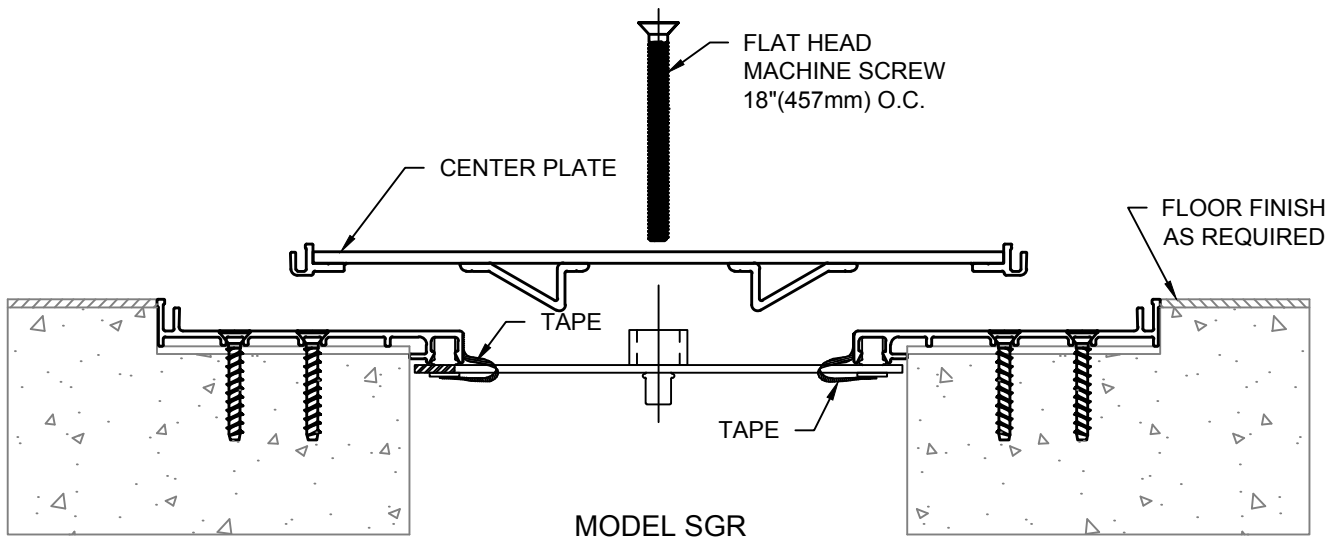

MODEL SGR

Step 5:

- 5.1) Prepare the Center Plate for installation by first cutting the Plate to length as needed.
- 5.2) Using the Center Plate drilled hole locations, measure and mark the Turnbar Centerline locations, on each side of the frame. A maximum of 18" o.c. between turnbar centerlines.
- 5.3) Place the Turnbar pivot pins at each end into the pivot pin receivers of the frame and align Turnbar centerline with the marked locations on the frame. (Note the orientation of the Turnbars on page 5.) Installed Turnbars when tightened will rotate in a clock wise motion.)
- 5.4) Tape Turnbar in place by attaching tape from the underside of turnbar up and around to the face of the frame. (See details) Remove any tape ends that extend above the frame.
- 5.5) Repeat the above steps taping each of the Turnbars to the frame to hold in place at each Turnbar centerline location on the frames.
- 5.6) Position the Center Plate on top of Frame and align the Turnbars with the holes in the Center Plate. Attach Turnbars using the CS supplied machine screws at 18" o.c. maximum.
- 5.7) Repeat this procedure for any additional lengths of Center Plate.

STEP 5 (Flr. to Wall Tape Method)

TAPE TURNBAR/CENTER PLATE INSTALLATION

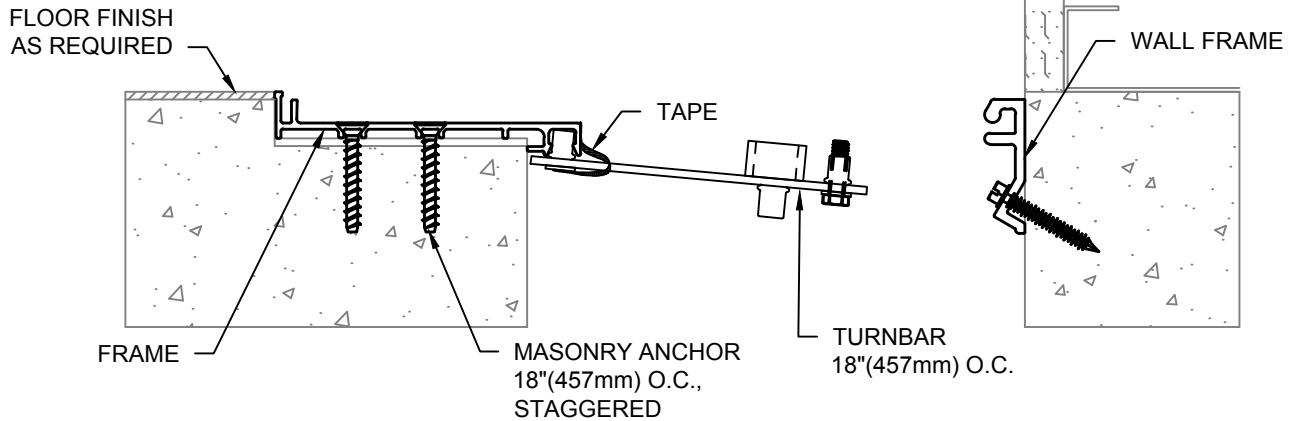

MODEL SGPW/SGRW

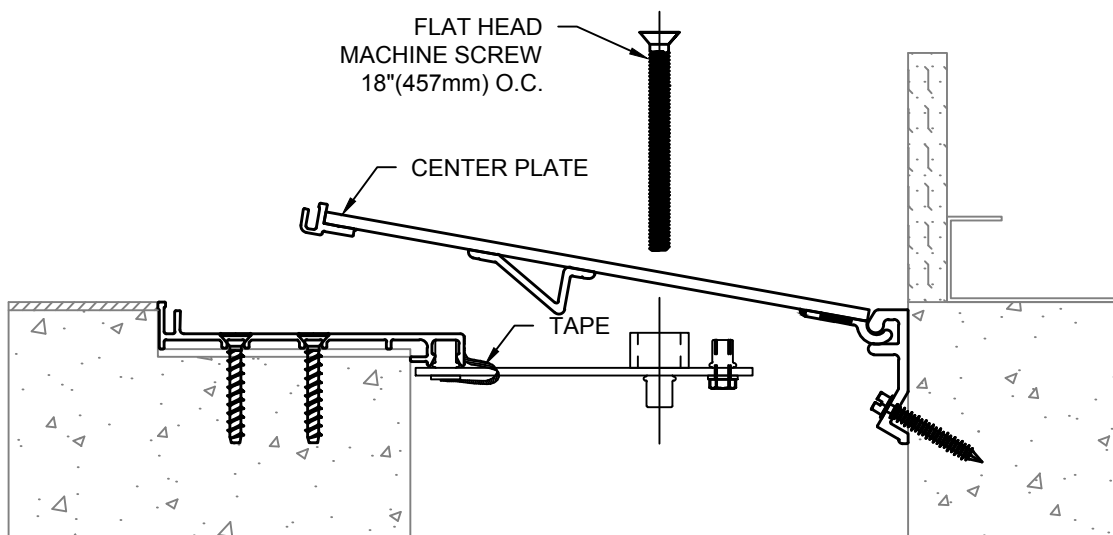

MODEL SGRW

Step 5:

- 5.1) Prepare the Center Plate for installation by first cutting the Plate to length as needed.
- 5.2) Using the Center Plate drilled hole locations, measure and mark the Turnbar Centerline locations, on each side of the frame. A maximum of 18" o.c. between turnbar centerlines.
- 5.3) Place the Turnbar pivot pins at each end into the pivot pin receivers of the frame and align Turnbar centerline with the marked locations on the frame. (Note the orientation of the Turnbar on Page 5. Installed Turnbars when tightened will rotate in a clock wise motion.) Tape the Turnbar in place by attaching tape from the underside of turnbar and around to the face of the frame. (See details) Remove any tape ends that extend above the frame. Repeat installation at each Turnbar centerline location on the frame.
- 5.4) Place Center Plate's hook into the hinge of the Wall Frame to position into place. Align the Turnbars with the holes in the Center Plate. Attach Turnbars using the CS supplied machine screws at 18" o.c. maximum. Repeat this procedure for any additional lengths of Center Plate.

STEP 6

GASKET INSTALLATION

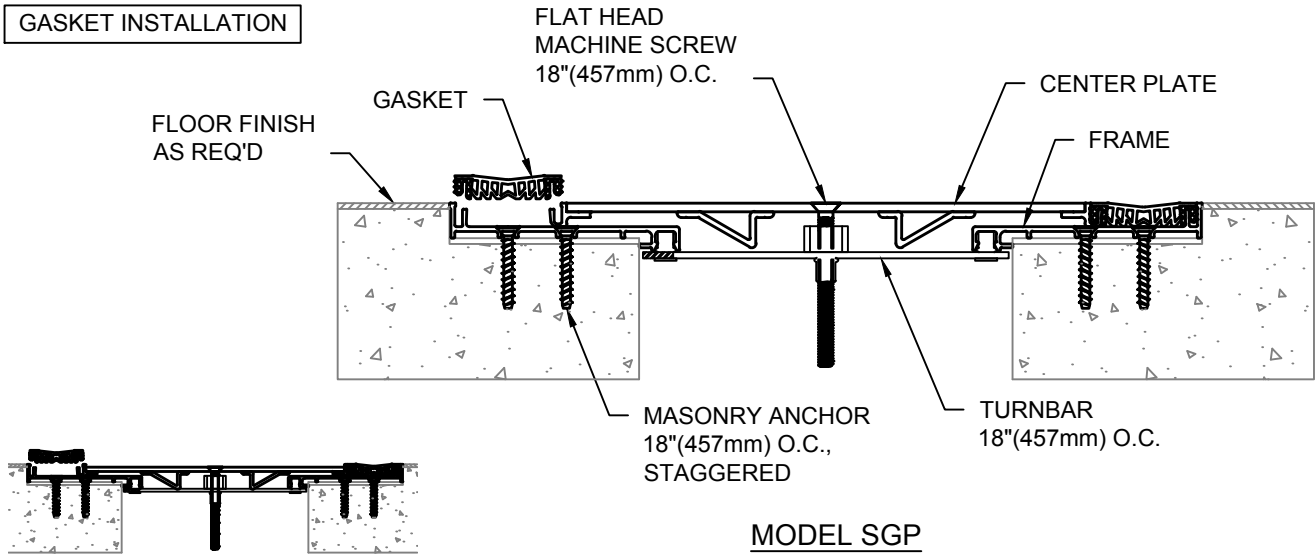

MODEL SGR

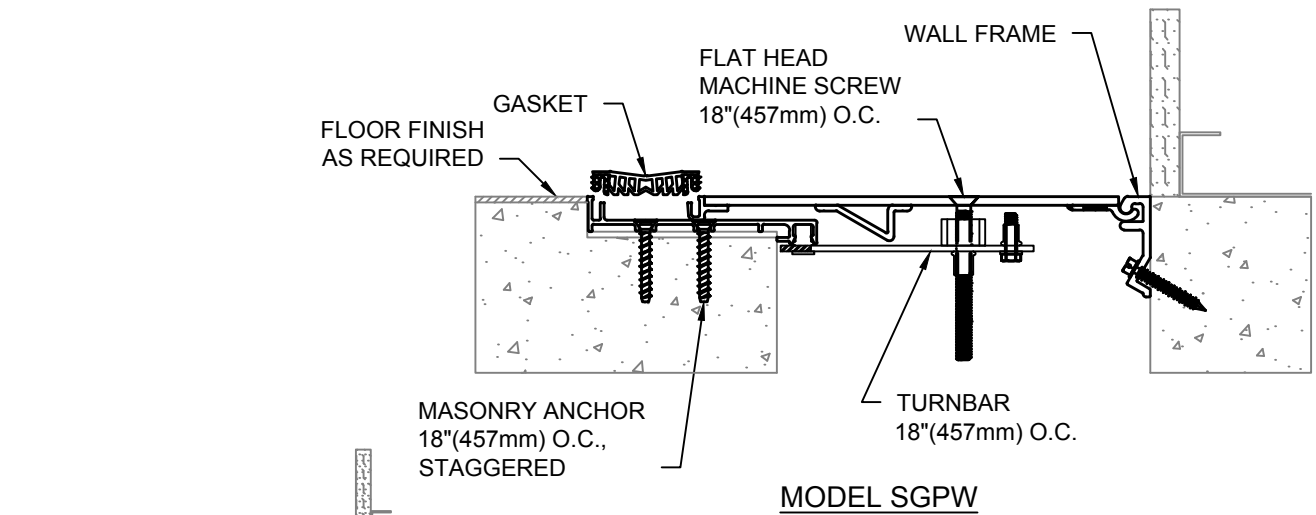

MODEL SGRW

Step 6:

- 6.1) Begin Gasket installation by inserting the Gaskets into the Frames and the Center Plates. It may be necessary to drive the Gasket in place using a rubber mallet and a wood block. See below for installation tips. When Gaskets are properly installed, they should be flush with the top surface of the Center Plate and Frames.

Tips: If capable, unroll the Gasket material and allow exposure to the sun until the material softens and becomes more pliable (approximately 30 minutes).

If you spray the push in arrow with soapy water, the Gasket slides in much easier.

STEP 7

COMPLETE INSTALLATION

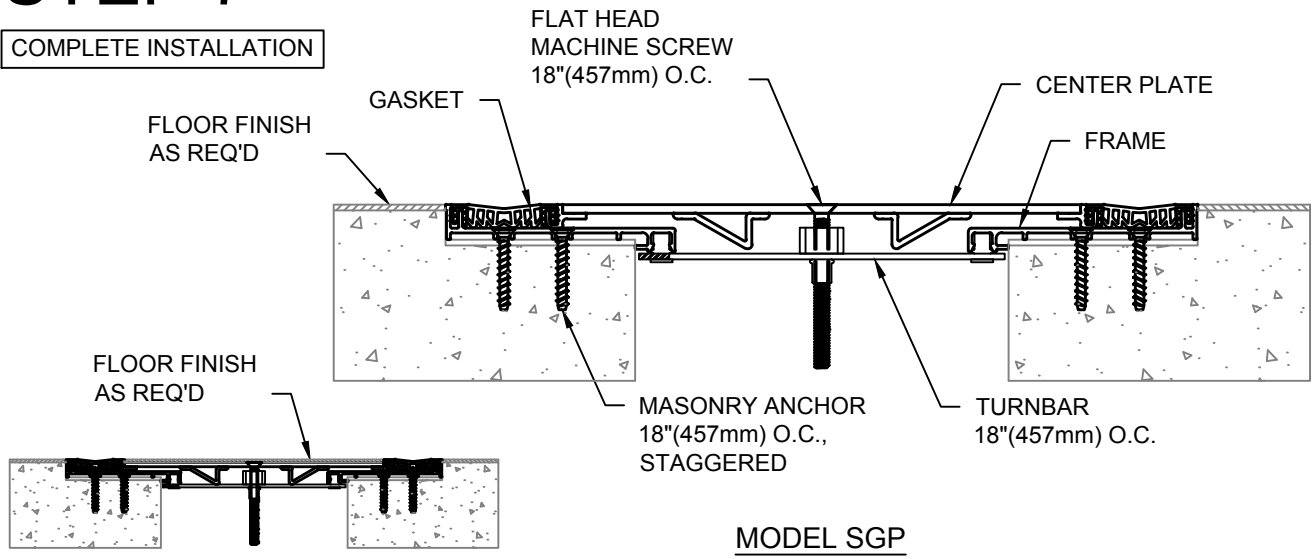

MODEL SGR

MODEL SGP

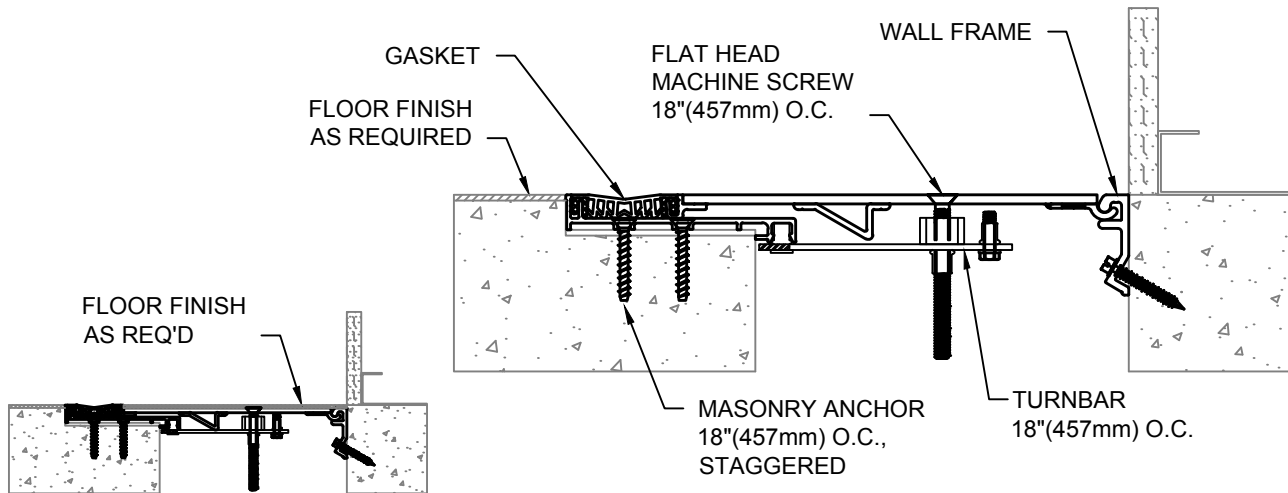

MODEL SGRW

MODEL SGPW

Step 7:

Note: Complete installation of models SGR/SGRW by installing the required floor finish in the Cover Plate.

- 7.1) When installation of the CS Floor Expansion Joint Cover has been completed, remove all residue and foreign matter from the area and joint cover.
- 7.2) Clean the CS Joint Cover and adjoining surfaces with proper cleaner.
- 7.3) Protect the Joint Cover until the Architect's final inspection.