

# SFC & SCC

**TECHNICAL DATA:**

**Aluminum**

- Extrusion – CS uses multiple alloys & tempers which are established to be the most appropriate for the given use of individual parts. Will be one of the following: (6063-T5, T6, T52) (6061-T5, T6, T51) (6105-T5, T6) (6005-T5) (6005A-T5, T61), ASTM B221
- Sheet – 6061-T6, 3003-H14, 5005-H34, ASTM B209

**Stainless Steel formed center plate**

- Type 304 ASTM A167, A240A, A240M
- No. 4 finish

**Bronze formed center plate**

- C28000 Muntz Metal ASTM B455
- Satin finish

**Duroflex Gasket**

- Single Durometer – 80 Shore A, ASTM D2000
- Color – Gray

**Turnbar**

- Material – C1075 Blue Temper Spring Steel
- Hardness – RC 44-47
- Finish – “A” Coating (Corrosion Protection)



MODEL	JOINT WIDTH	MINIMUM OPENING	MAXIMUM OPENING	EXPOSED SURFACE	BLOCKOUT WIDTH	BLOCKOUT HEIGHT
SFC-400	4.00" (102mm)	2.88" (73mm)	7.25" (184mm)	7.50" (191mm)	N/A	N/A
SFC-500	5.00" (127mm)	2.88" (73mm)	9.50" (241mm)	10.50" (267mm)	N/A	N/A
SFC-600	6.00" (152mm)	2.88" (73mm)	9.50" (241mm)	11.94" (303mm)	N/A	N/A
SFC-700	7.00" (178mm)	2.88" (73mm)	13.25" (337mm)	13.50" (343mm)	N/A	N/A
SFC-800	8.00" (203mm)	2.88" (73mm)	14.38" (365mm)	15.00" (381mm)	N/A	N/A
SFC-900	9.00" (229mm)	2.88" (73mm)	14.38" (365mm)	16.50" (419mm)	N/A	N/A
SFC-1000	10.00" (254mm)	2.88" (73mm)	17.63" (448mm)	17.94" (456mm)	N/A	N/A
SFC-1100	11.00" (279mm)	2.88" (73mm)	18.63" (473mm)	19.50" (495mm)	N/A	N/A
SFC-1200	12.00" (305mm)	2.88" (73mm)	18.63" (473mm)	21.00" (533mm)	N/A	N/A
SFC-1300	13.00" (330mm)	2.88" (73mm)	22.00" (559mm)	22.50" (572mm)	N/A	N/A
SFC-1400	14.00" (356mm)	2.88" (73mm)	23.00" (584mm)	23.94" (608mm)	N/A	N/A
SFC-1500	15.00" (381mm)	2.88" (73mm)	23.00" (584mm)	25.50" (648mm)	N/A	N/A
SFC-1600	16.00" (406mm)	2.88" (73mm)	26.00" (660mm)	27.00" (686mm)	N/A	N/A

Use chart above for stainless steel and bronze options.  
Call the factory for larger sizes.

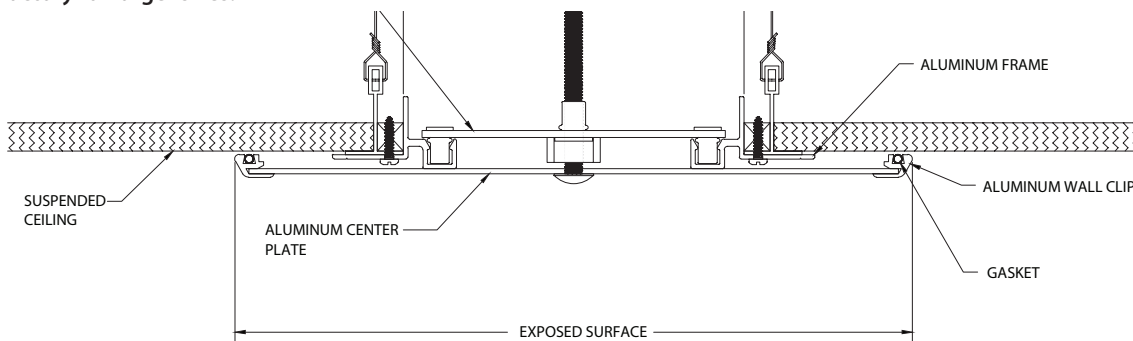

SFC

# SFC & SCC

MODEL	JOINT WIDTH	MINIMUM OPENING	MAXIMUM OPENING	EXPOSED SURFACE	BLOCKOUT WIDTH	BLOCKOUT HEIGHT
SCC-400	4.00" (102mm)	0.00" (0mm)	5.50" (140mm)	5.75" (146mm)	N/A	N/A
SCC-500	5.00" (127mm)	0.00" (0mm)	7.50" (191mm)	7.75" (197mm)	N/A	N/A
SCC-600	6.00" (152mm)	0.00" (0mm)	8.75" (222mm)	9.00" (229mm)	N/A	N/A
SCC-700	7.00" (178mm)	4.94" (125mm)	10.13" (257mm)	10.25" (260mm)	N/A	N/A
SCC-800	8.00" (203mm)	5.44" (138mm)	11.19" (284mm)	11.50" (292mm)	N/A	N/A
SCC-900	9.00" (229mm)	5.94" (151mm)	11.69" (297mm)	12.75" (324mm)	N/A	N/A
SCC-1000	10.00" (254mm)	6.44" (164mm)	13.88" (353mm)	14.00" (356mm)	N/A	N/A
SCC-1100	11.00" (279mm)	6.94" (176mm)	14.81" (376mm)	15.25" (387mm)	N/A	N/A
SCC-1200	12.00" (305mm)	7.44" (189mm)	15.31" (389mm)	16.50" (419mm)	N/A	N/A
SCC-1300	13.00" (330mm)	7.94" (202mm)	17.63" (448mm)	17.75" (451mm)	N/A	N/A
SCC-1400	14.00" (356mm)	8.44" (214mm)	18.38" (467mm)	19.00" (483mm)	N/A	N/A
SCC-1500	15.00" (381mm)	8.94" (227mm)	18.88" (480mm)	20.25" (514mm)	N/A	N/A
SCC-1600	16.00" (406mm)	9.44" (240mm)	19.38" (492mm)	21.50" (546mm)	N/A	N/A

Use chart above for stainless steel and bronze options.  
Call the factory for larger sizes.

