

MODEL HB-100 through 400 INSTALLATION INSTRUCTIONS

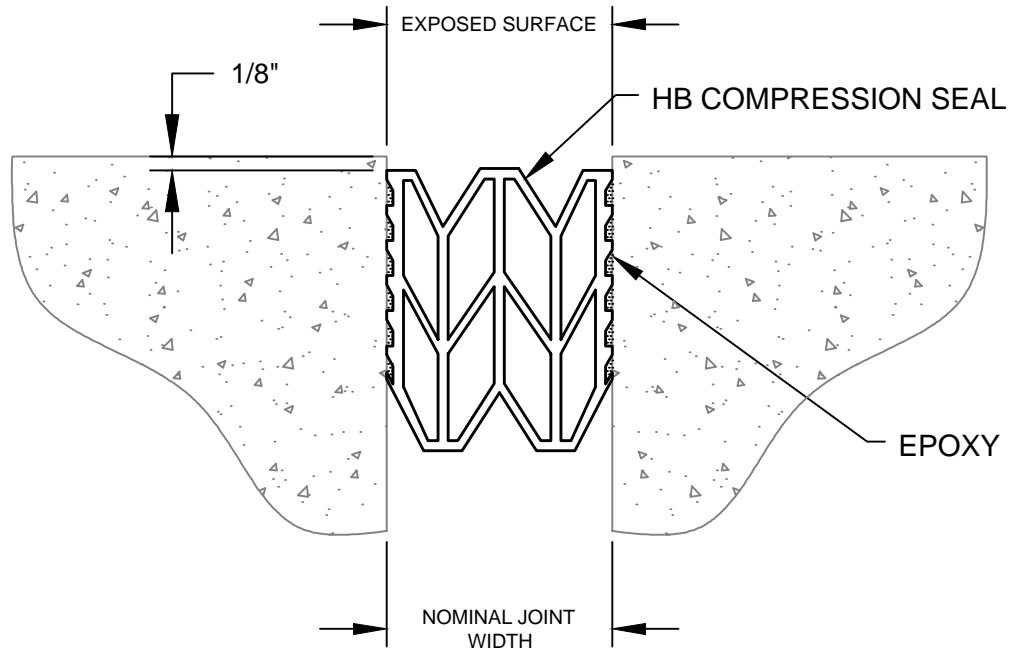

IMPORTANT INFORMATION

Prior to the commencement of Installation, all materials **MUST** be inspected for Damage. Any damage must be reported to CONSTRUCTION SPECIALTIES, INC., as soon as possible, so that replacement materials may be furnished without delay.

All work must be completed as per Architect's Approved "Shop Drawings", and in accordance with these Installation Instructions. When installation is complete, all materials must be protected from damage until the Architect's FINAL INSPECTION.

All materials should be arranged in the order that they are to be installed. All hardware required for each portion of the work should be placed with the appropriate materials.

Please review all Approved Shop Drawings and this Document to familiarize yourself with all the details and components of this assembly.

IMPORTANT:
READ THROUGH ALL INSTRUCTIONS PRIOR TO STARTING INSTALLATION

1/20/2015



Construction Specialties™

6696 Route 405 Highway, Muncy PA 17756
(800) 233-8493 • Fax (570) 546-5169 • www.c-sgroup.com

This document is the property of Construction Specialties, Inc. and contains CONFIDENTIAL PROPRIETARY INFORMATION that is not to be disclosed to third parties and is not to be used without approval in writing from Construction Specialties, Inc.

GENERAL NOTES:

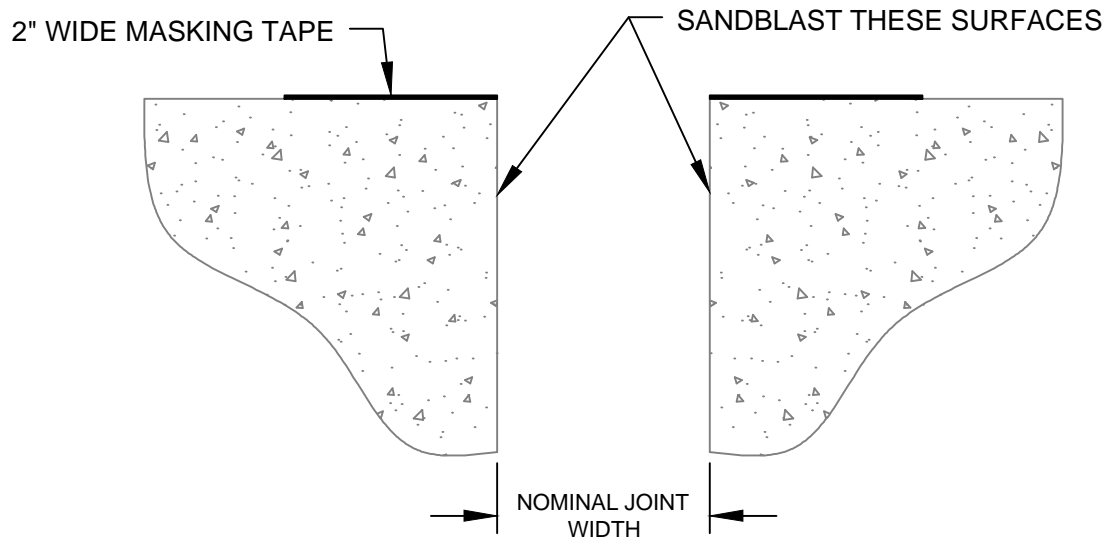

Notes:

Before beginning installation, review the architectural drawings and approved Construction Specialties Inc. shop drawings to familiarize yourself with the appropriate joint cover models and locations.

Check all of the joint cover components to confirm that the correct joint cover model and size have been received. Also, check for materials that may have been damaged during shipping. Report all incorrect and/or damaged components to C/S at 800-233-8493.

Read through all the steps of these instructions prior to beginning work and note requirements for splicing, corners, T's and intersections.

Before beginning installation of the HB Compression Seal, review the layouts for the various runs of seal as detailed on the approved Construction Specialties shop drawings.

The "HB" series Compression Seals must be securely mounted to structurally sound concrete that has cured for at least 7 days.

The joint must be sandblasted to expose new concrete and remove all form release agents and other foreign materials. See detail above.

The surface of the joints must be clean and free from any loose dust, dirt, debris and oils that would affect the installation of the seal, or adhesion of the epoxy.

Refer to the Construction Specialties Expansion Joint Tech Manual for proper joint width at time of seal installation.

IMPORTANT NOTE: Do not use epoxy or install this seal if either the substrate temperature or air temperature will drop below 40°F (5°C) during the installation or cure time of 8 hours.

STEP 1

PREPARE SEAL

- 1.1) Before beginning installation, apply 2" masking tape on both sides of the joint.
- 1.2) Unroll each length of Compression Seal and lay each one down next to the joint where it is to be installed. This will allow the seal some time to relax before it is installed.
- 1.3) Wire brush the sides of the compression seal thoroughly using a drill or grinder with a wire wheel mounted in the chuck. All wire brushed surfaces should have a dull black appearance when finished. There should be no gloss or white residue left on these surfaces. The epoxy may not bond properly if the seal is not thoroughly wire brushed.
- 1.4) Wire brush the top surface of the seal at the last 3" of the seal where it will butt up to an adjacent section of seal until all surfaces are dull black as in step 1.3)
- 1.5) Clean the seal thoroughly using compressed air to remove any loose debris.
- 1.6) Make sure that the ends of the seal are cut square and clean.

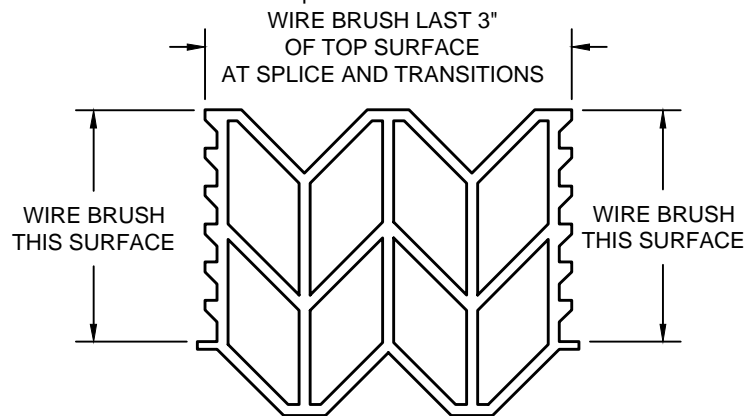

STEP 2

MIXING THE EPOXY

- 2) Mix the Construction Specialties supplied, 2 part epoxy.
 - 2.1) Measure equal amounts of Part A and Part B by volume.
 - 2.2) Pour both Part A and Part B into a container and mix thoroughly for three minutes until a uniform gray color is achieved.

Note: Do not mix in direct sunlight as this will decrease the work life of the epoxy. Only mix the amount of epoxy that can be used within its gel time. See chart below for gel time based on temperature.

IMPORTANT NOTE: Do not use epoxy or install this seal if either the substrate temperature or air temperature will drop below 40°F (5°C) during the installation or cure time of 8 hours

APPROXIMATE WORK LIFE OF EPOXY	
TEMPERATURE °F	WORK LIFE
50	35 MINUTES
70	25 MINUTES
85	20 MINUTES

STEP 3

APPLYING THE EPOXY

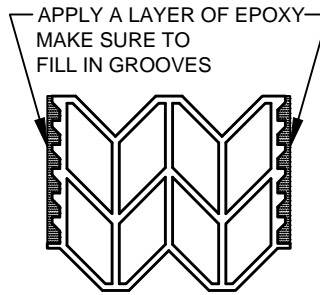

- 3.1) Apply the epoxy by spreading the epoxy with a trowel until it is approximately 1/8" - 3/16" thick. Make sure to fill in all of the grooves on the Compression Seal. See detail above. The epoxy must be applied quickly to allow time for the seal to be installed before it begins to gel. Once the epoxy has begun to gel or get hot, a proper bond will not be achieved.

STEP 4

BEGIN INSTALLATION

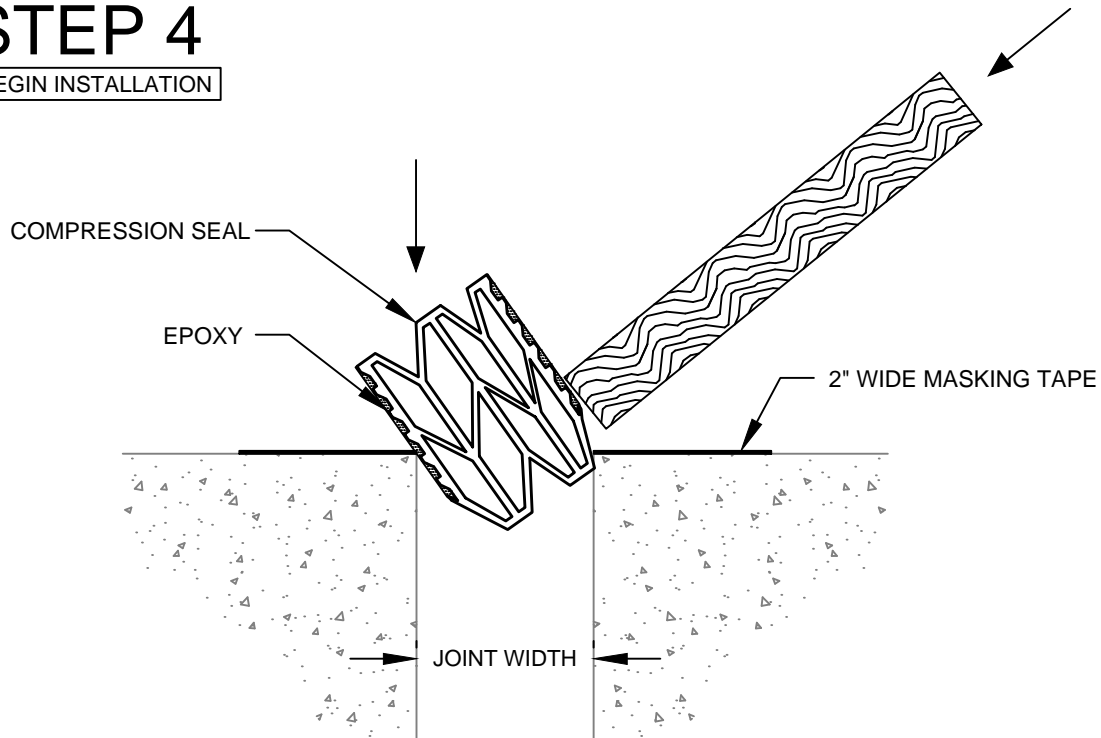

- 4.1) Starting at one end of the seal, push inward on the Compression Seal using a shaft (3/4" plywood, metal bar stock, etc.). See detail above. As you push inward on the Compression Seal every few inches, have someone follow behind you walking on the seal to seat it into place. Recess the Compression Seal approximately 1/8" into the joint (see below).

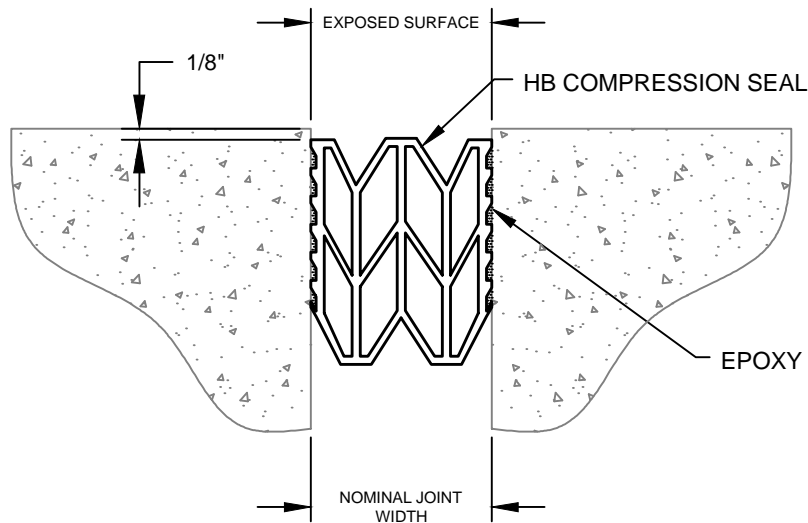

STEP 5

CONTINUE INSTALLATION

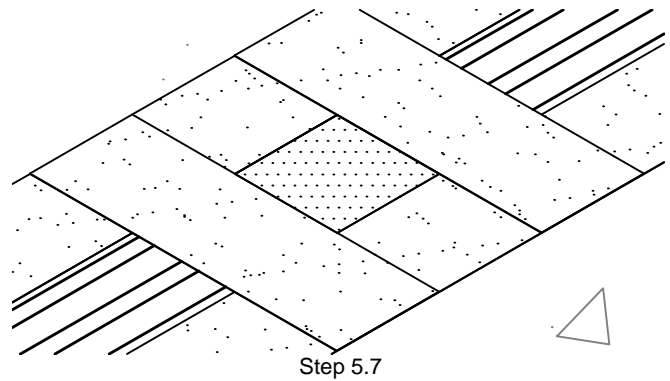
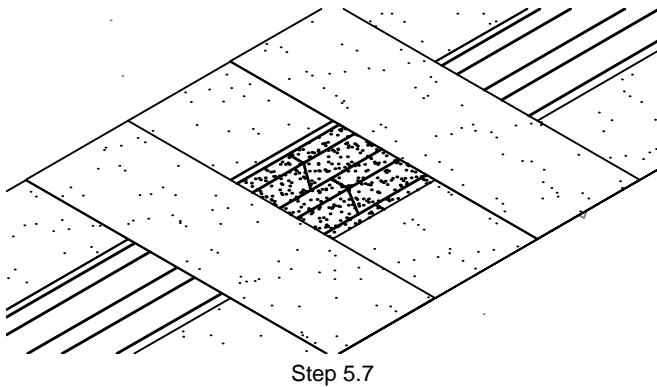
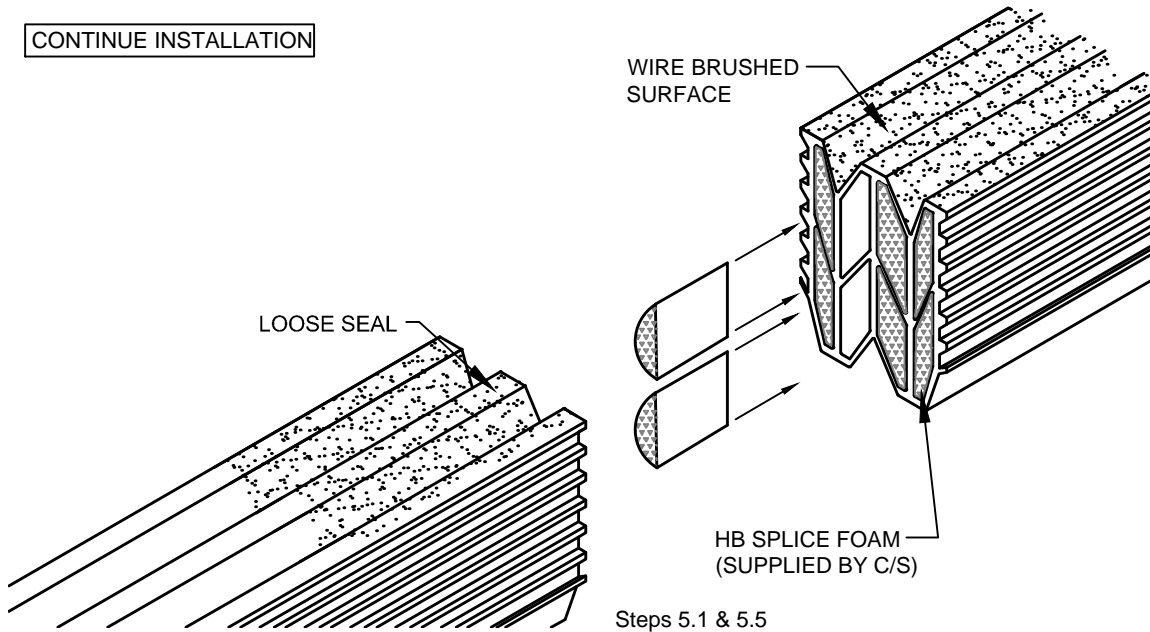

*NOTE: SPLICE KITS SOLD SEPARATELY

- 5.1) Wire brush to create a rough surface on the seal approx. 3" from the edge. Wire brushed area should have a dull black appearance when finished. Clean seal thoroughly using compressed air to remove any loose rubber particles left behind from the wire brush.
- 5.2) Install C/S supplied open cell HB Splice Foam in ends of HB cell openings at this point.
- 5.3) Ensure that the ends of the next seal to be installed are cut square, clean and if necessary, cut to length.
- 5.4) Apply Construction Specialties supplied Splice Sealant to the face of seal on the next section of seal.
- 5.5) Place 5-6 inches of the end of the next section of seal into the joint and align with the end of the previously installed section.
- 5.6) Slide the Compression Seal against the end of the previous section, making sure that there is no gap between the ends of the seals.
- 5.7) Place the remaining length of seal in and install according to Step 4.
- 5.8) Apply tape on both sides of the splice approximately 2" away from the splice. Apply the Construction Specialties supplied Splice Sealant over the top of the splice. Smooth the surface of the compound using a putty knife.

STEP 5

CONTINUE INSTALLATION

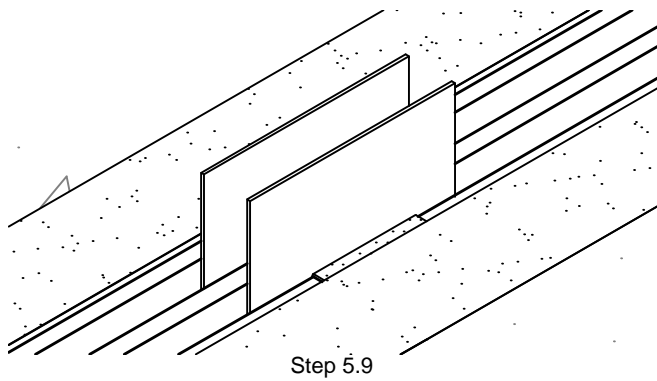
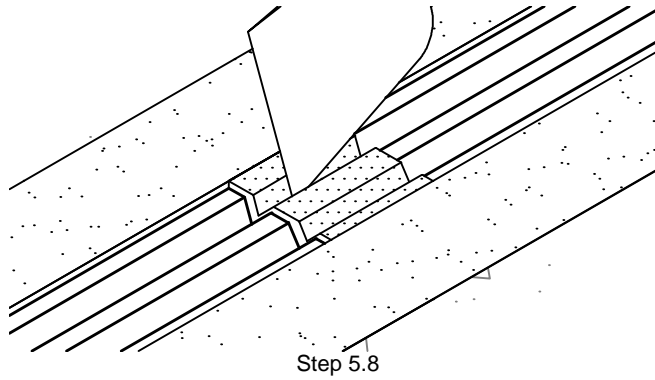

- 5.8) Remove the tape and open the "V's" of the seals with a dull putty knife. Do not remove all of the sealant from the bottom of the "V's". Leave approx. 1/8" of sealant on the bottom of the "V".
- 5.9) Place the supplied 2" x 8" strips of Polyethylene into the "V's" to prevent them from sticking together during cure time.
- 5.10) Repeat these procedures for any additional lengths of seal.
- 5.11) Once the sealant has cured over the seals (24 - 48 hrs.), then remove the Polyethylene Strips.

STEP 6

ANGLED INTERSECTION

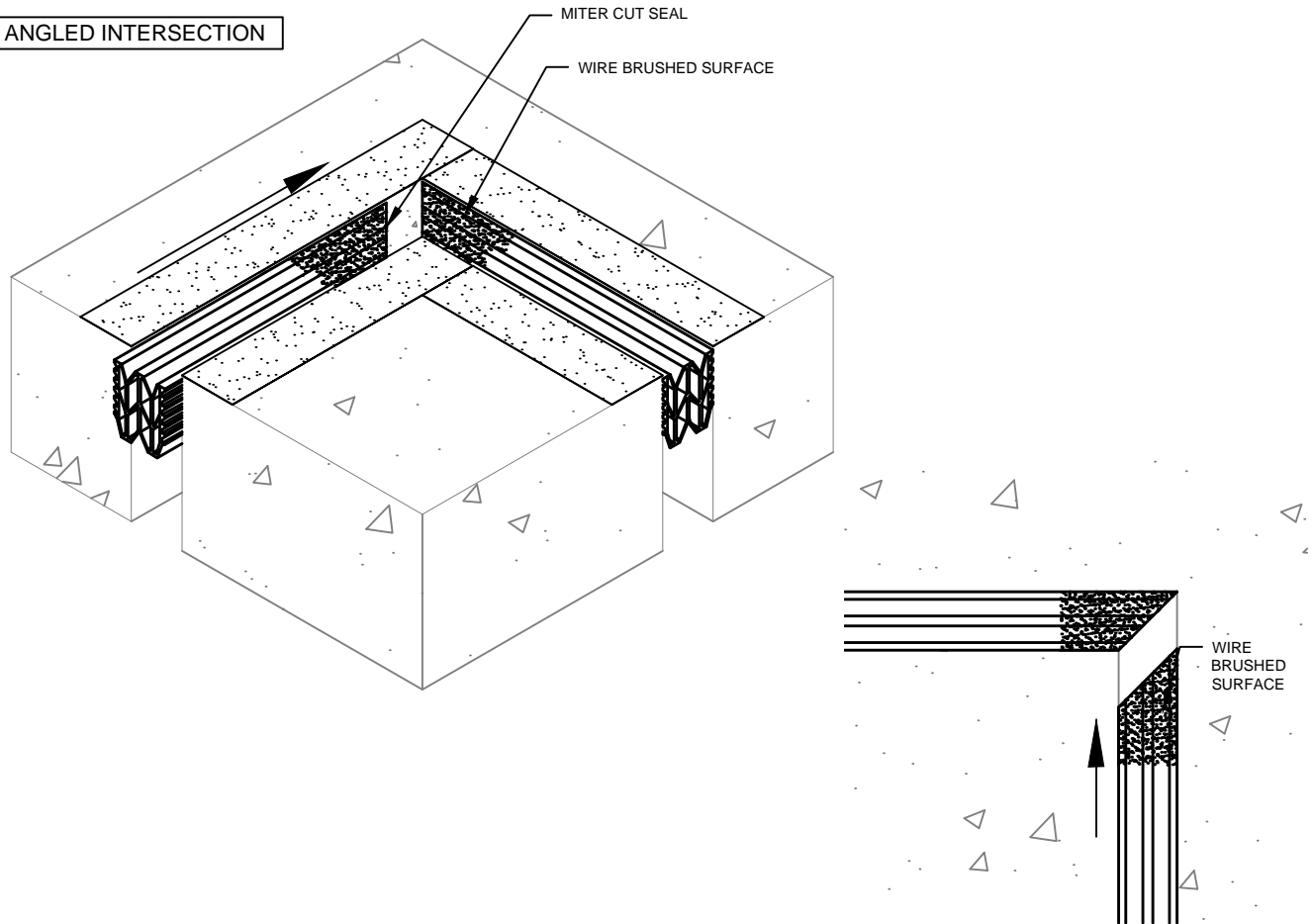

Note: When cutting seals for transitions, the seal must be compressed to its nominal size in order for the seal to match up when cut properly.

- 6.1) Miter the ends of the Compression Seals to 45° angle.
- 6.2) Wire brush the ends of the seals 3" back from the mitered cut until the surface is a dull black and all shininess is removed. Clean seal thoroughly using compressed air to remove any loose rubber particles left behind from the wire brush.
- 6.3) Install the first section of seal according to Steps 1-4. Ensure that the miter cut end is at the proper location.
- 6.4) Install C/S supplied open cell HB Splice Foam in ends of HB cell openings at this point.
- 6.5) Apply Construction Specialties supplied Splice Sealant to face of seal on the next section of seal.
- 6.6) Place the end of the next section of seal in the joint according to Steps 3-4, but only press the first 5-6 inches of the seal into the joint and align with the previously installed section.
- 6.7) Slide the seal against the end of the installed section so there is no gap between the seals.
- 6.8) Continue to install the remaining length of the seal into the joint according to Step 4.
- 6.9) Apply Construction Specialties supplied Splice Sealant over the top of the splice in accordance with Step 5.

STEP 7

"T" INTERSECTION

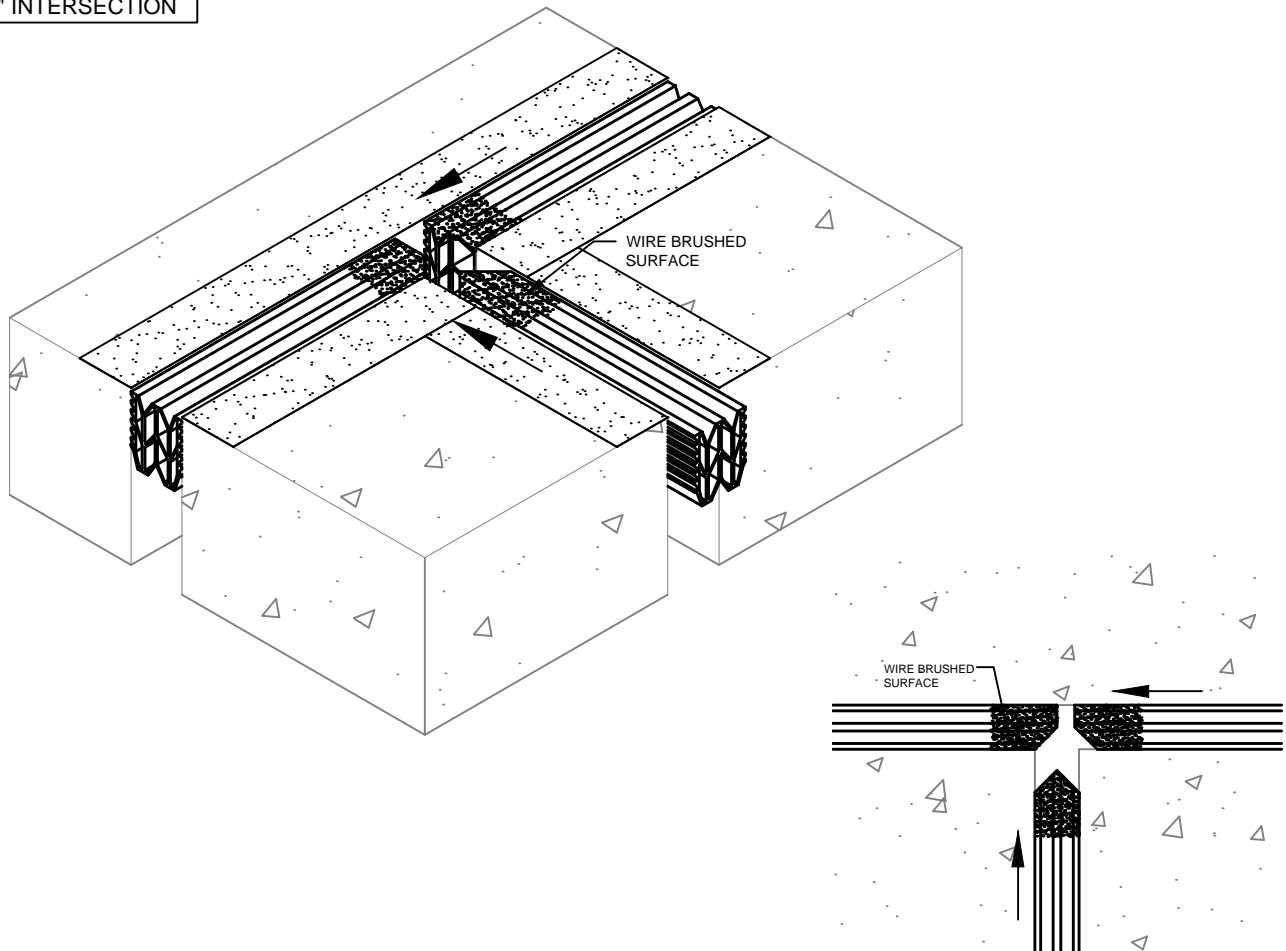

Note: When cutting seals for transitions, the seal must be compressed to its nominal size in order for the seal to match up when cut properly.

- 7.1) At the two adjoining runs of seal, make a 45° cut through half the seal on both ends as shown above so when slid together, a 'V' remains to the perpendicular section of seal to butt.
- 7.2) V-cut the end of the mating seal so that all seals will fit together properly (see above).
- 7.3) Wire brush the ends of the seals 3" back from the mitered cut until the surface is a dull black and all shininess is removed. Clean seal thoroughly using compressed air to remove any loose rubber particles left behind from the wire brush.
- 7.4) Install C/S supplied open cell HB splice foam in ends of HB cell openings at this point.
- 7.5) Apply Construction Specialties supplied Splice Sealant to face of seal on the next section of seal.
- 7.6) Place the end of the next section of seal in the joint according to Steps 3-4, but only press the first 5-6 inches of the seal into the joint and align with 90° miter cut of the previously installed section.
- 7.7) Slide the seal against the V-cut of the installed section so there is no gap between the seals.
- 7.8) Continue to install the remaining length of seal into the joint blockout according to Step 4.
- 7.9) Apply Construction Specialties supplied Splice Sealant over top of the splice in accordance with Step 5.

STEP 8

CROSS INTERSECTION

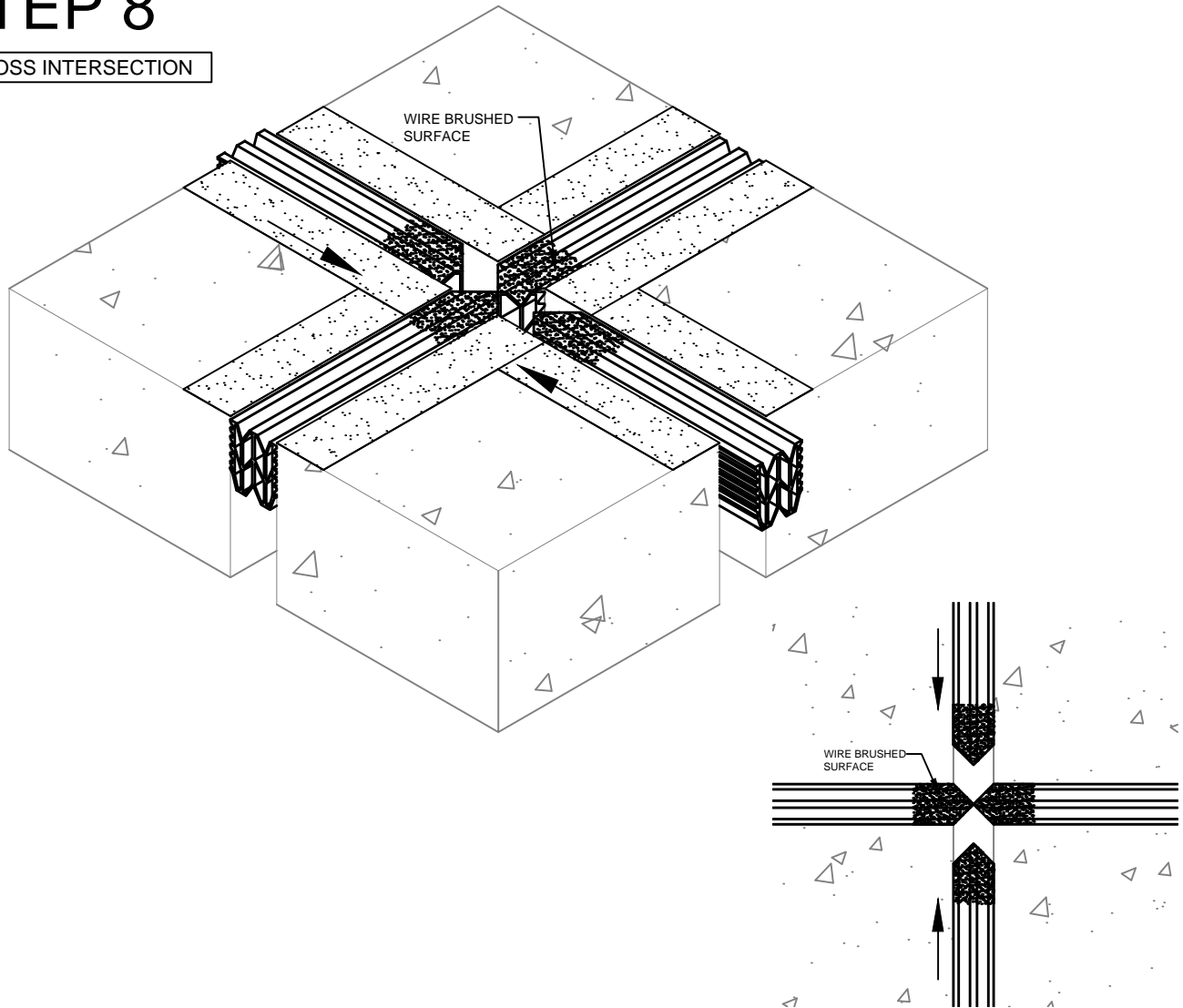

Note: When cutting seals for transitions, the seal must be compressed to its nominal size in order for the seal to match up properly when cut.

- 8.1) 90° V-cut each side of the main run of seal at the joint intersection.
- 8.2) V-cut the end of the mating sections of seal to allow them to fit properly with the main run.
- 8.3) Wire brush the top surface of the seal 3" back from the cut end until the area has a dull black appearance. Clean seal thoroughly using compressed air to remove any loose rubber particles left being from the wire brush.
- 8.4) Install C/S supplied open cell HB splice foam in ends of HB cell openings at this point.
- 8.5) Apply Construction Specialties supplied Splice Sealant to face of seal on the next section of seal.
- 8.6) Place the end of the next section of seal in the joint according to Step 4, but only press the first 5-6 inches of the seal into the joint and align with 90° miter cut of the previously installed section.
- 8.6) Slide the seal against the V-cut of the installed section so there is no gap between the seals.
- 8.8) Repeat these procedures to the opposite side of the splice.
- 8.9) Continue to install the remaining lengths of seal into the joint blockout according to Step 4.
- 8.10) Apply Construction Specialties supplied Splice Sealant over the top of the splices in accordance with Step 5.

STEP 9

VERTICAL INTERSECTION

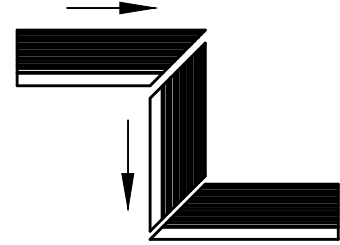
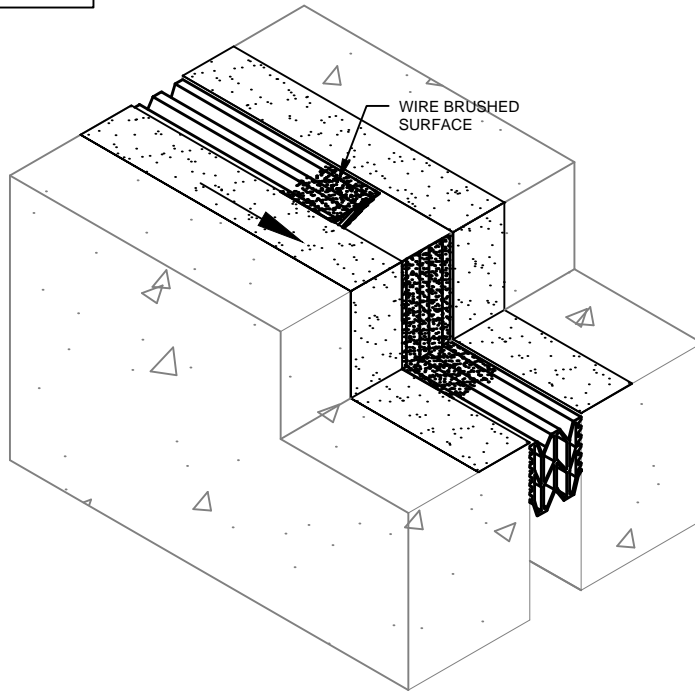

Note: When cutting seals for transitions, the seal must be compressed to its nominal size in order for the seal to match up when cut properly.

- 9.1) Miter cut the ends of the mating section of the seals.
- 9.2) Wire brush the top surface of the seal 3" back from the cut end until the area has a dull black appearance. Clean seal thoroughly using compressed air to remove any loose rubber particles left behind from the wire brush.
- 9.3) Install C/S supplied open cell HB Splice Foam in ends of HB cell openings at this point.
- 9.4) Install the bottom horizontal run of seal following Steps 1-4. Ensure that the mitered end of the seal is located properly in the joint.
- 9.5) Apply Construction Specialties supplied Splice Sealant to face of seal on the next section of seal.
- 9.6) Place the end of the vertical section of seal in the joint according to Step 4, but only press the first 5-6 inches of the seal into the joint and align with horizontal seal.
- 9.7) Slide the vertical seal against the horizontal seal so there is no gap between the seals.
- 9.8) Continue to install remaining length of seal in accordance with Step 4.
- 9.9) Apply Construction Specialties supplied Splice Sealant to face of seal on the next section of seal.
- 9.10) Place the end of the top horizontal section of seal in the joint according to Step 4, but only press the first 5-6 inches of the seal into the joint and align with vertical seal. Ensure that the mitered end of the seal is located properly in the joint.
- 9.11) Slide the top horizontal seal against the vertical seal so there is no gap between the seals.
- 9.12) Continue to install remaining length of seal in accordance with Step 4.
- 9.13) Apply more Construction Specialties supplied Splice Sealant over the top of the splices in accordance with Step 5.

STEP 10

COMPLETE INSTALLATION

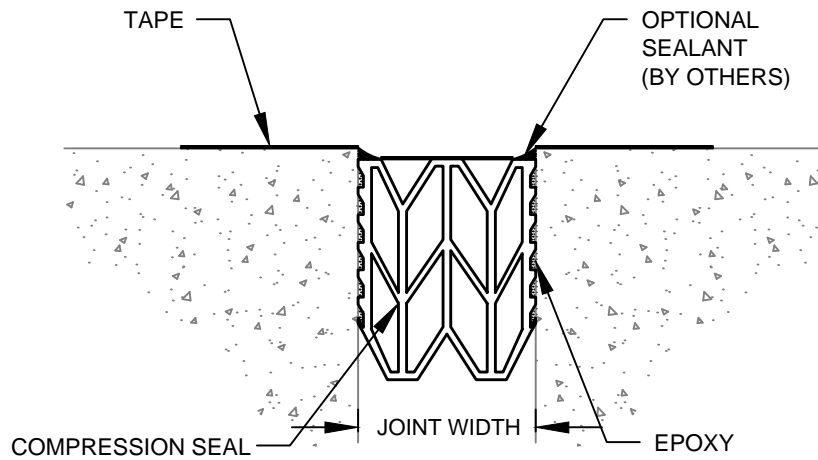

- 10.1) Optional: A Polyurethane sealant (by others) can be applied to the edge of the seal as shown above.
- 10.2) Remove tape and any excess debris.
- 10.3) Allow 24 to 48 hours for the splicing adhesive to cure before removing the polyethylene strips.
- 10.4) This completes the installation of the HB Seal Models.